

Ramp Wave Compression in a Copper Strip Line: Comparison Between MHD Numerical Simulations (LS-DYNA[®]) and Experimental Results (GEPI device)

Gaël Le Blanc¹, Pierre-Yves Chanal², Pierre-Louis Hereil²,
Patrice LaPorte¹, Gilles Avrillaud¹, Paul Vincent¹ and Pierre L'eplattenier³

¹ITHPP – Drèle – 46500 Thégra, France

²Centre d'Etudes de Gramat - 46500 Gramat, France

³LSTC – Livermore, CA – USA

Abstract

GEPI [3][4] is a pulsed power generator developed by ITHPP for Centre d'Etudes de Gramat (CEG) devoted to ramp wave (quasi isentropic) compression experiments in the 1 GPa to 100 GPa range and to non shocked high velocity flyer plate in the 0.1 km/s to 10 km/s range.

The aim of this paper is to compare numerical simulation and experimental results on a 3D GEPI configuration. A coupled mechanical / thermal / electromagnetism simulation has been performed to validate the new LS-DYNA beta version, ls980, where the electromagnetism package has been implemented. The validation is realized by free surface velocity comparisons on a reference configuration [5].

The study is presented in three main steps. First, a validation of LS-DYNA is performed by comparison to an analytical model and to another electromagnetic solver modeling a basic configuration. In the second step, the GEPI configuration is described and experimental strip line free surface velocities are analyzed. Then LS-DYNA models are presented. The model validation is realized by free surface velocity comparisons between LS-DYNA and GEPI results. As the electromagnetism solver requires a lot of memory, in order to optimize the memory used as well as the CPU time, the electromagnetic domain is limited to the "launcher" with a thickness around 1 mm. The rest of the strip line is merged to the "launcher" and the mechanical solver only is used there. The last section of this study presents the optimization of the strip line geometry in order to improve the magnetic pressure homogeneity along this strip line.

1. Introduction

GEPI [3][4] is a pulsed power generator developed by ITHPP for Centre d'Etudes de Gramat devoted to ramp wave (quasi isentropic) compression in the 1 GPa to 100 GPa range and to non shocked high velocity plate in the 0.1 km/s to 10 km/s range. The GEPI and the loading principle are presented figure 1.

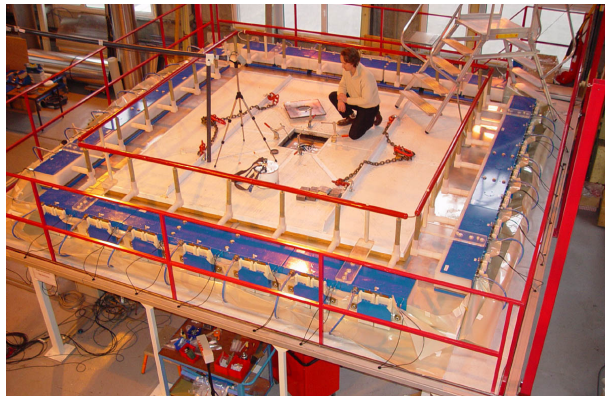

Picture of GEPI (6m x 6m)

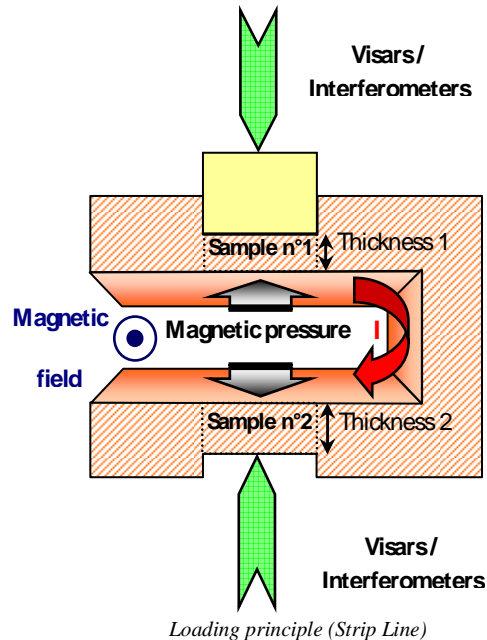

Figure 1 : GEPI and loading principle [3] [4].

The aim of this study is to define an optimal strip line geometry in order to improve the magnetic pressure homogeneity along this strip line. The LS-DYNA beta version (1s980) where the electromagnetism package has been implemented is used to participate to the optimization task. Coupled mechanical / thermal / electromagnetism simulations have been performed for that. The LS-DYNA validation is essentially performed by free surface velocities comparisons with experimental results [5].

The study is presented in three main steps. First, the electromagnetic LS-DYNA solver is briefly described. Then a basic model is performed to validate LS-DYNA by comparison to analytical solutions and to ANSYS results. The second step consists in presenting the initial GEPI configuration. Experimental free surface velocities results are analyzed (this velocity distribution depends on the spatial distribution of the magnetic pressure in the gap). A corresponding LS-DYNA model is then presented.

This analysis showed that the actual spatial distribution of the magnetic pressure in the strip line gap was inhomogeneous, and many improvements of the geometry have been proposed. Hence, a new strip line geometry has been defined and is presented in the last section of the paper.

2. Electromagnetism in LS-DYNA and first validation

An electromagnetism module is under development in LS-DYNA in order to perform coupled mechanical/thermal/electromagnetic simulation. This module allows solving the Maxwell equations in the eddy-current approximation, in order to compute the magnetic field, the electric field and the induced current, from some source electrical current into solid conductors. These equations are solved using a Finite Element Method (FEM) for the solid conductors coupled with a Boundary Element Method (BEM) for the surrounding air or insulators [6][7][8]. The BEM avoids meshing the air. We are going to bench the BEM on a model close to GEPI configuration.

The first validation consists in comparing LS-DYNA results [1] [2] to analytical and to ANSYS results using a basic magnetodynamic configuration. This model has been made without

thermal or mechanical coupling. It is a basic strip line (U-shape geometry, see Figure 2). The model options are very similar between LS-DYNA and ANSYS (mesh, material, geometry [13] [14]). The main difference comes from the lack of an air mesh in the LS-DYNA approach (Boundary Element Method [6] [7]) compared to the need of an air mesh in the ANSYS simulation. An analytical model [11] [14] also allows estimating the magnetic diffusion (steady and transient terms) through the electrode thickness (in the first cell).

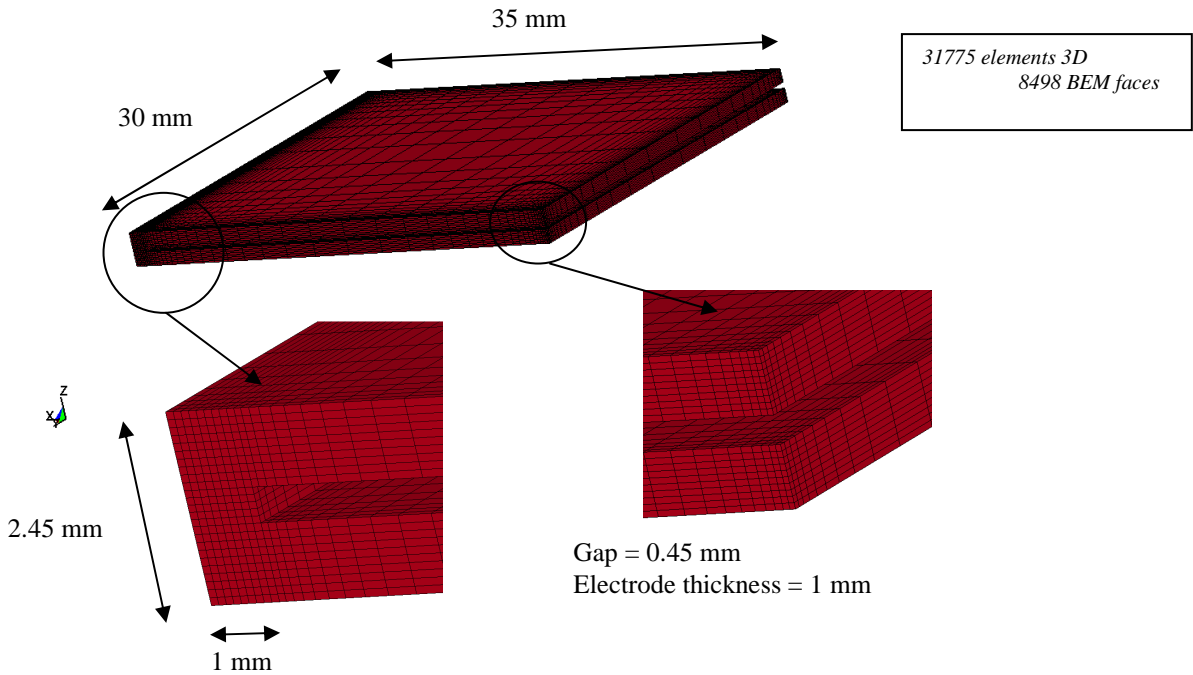

Figure 2 : LS-DYNA validation – model.

The comparisons between LS-DYNA / ANALYTICAL / ANSYS are presented Figure 3 on magnetic pressure.

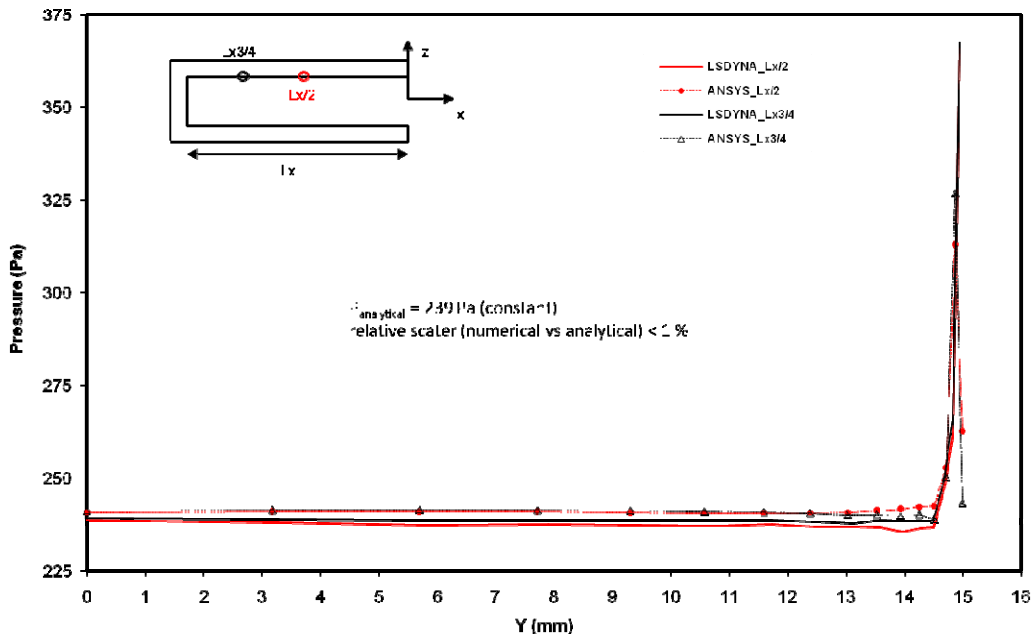

Figure 3 : LS-DYNA validation – magnetic pressure at 600 ns.

The LS-DYNA results are very close to both the analytical and the ANSYS solutions. The relative error is lower than 1 %. LS-DYNA seems to be reliable to describe a real GEPI shot.

3. Initial GEPI electrode configuration (CEG - GEPI shot n°465)

3.1 Experimental configuration and results

The experimental configuration is presented figure 4. The strip line and hexagonal design is described here [12] [13] [14].

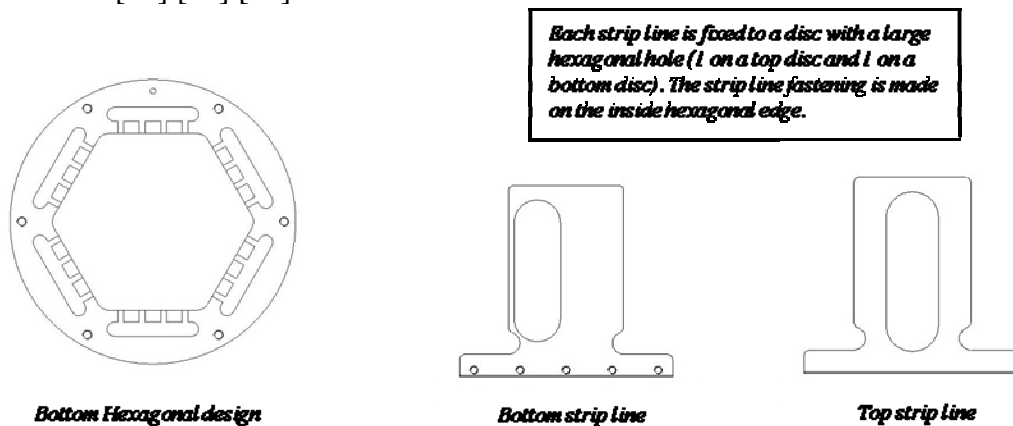

Figure 4 : GEPI shot 465 – experiment setting.

Using this kind of configuration reduces the cost and turn around time because only the end on strip line has to be remade at each shot. The same hexagonal design can be used for 6 shots.

The experimental results, current measurement and free surface velocities, are presented below. The current density is measured locally on 12 points around the load at a 364 mm diameter using an inductive groove (MCCI) [12], developed by ITHPP. The average current is presented Figure 5 and is in agreement with another current measurement from a Rogowsky coil. Interferometer free surface velocity measurements are also shown on Figure 5.

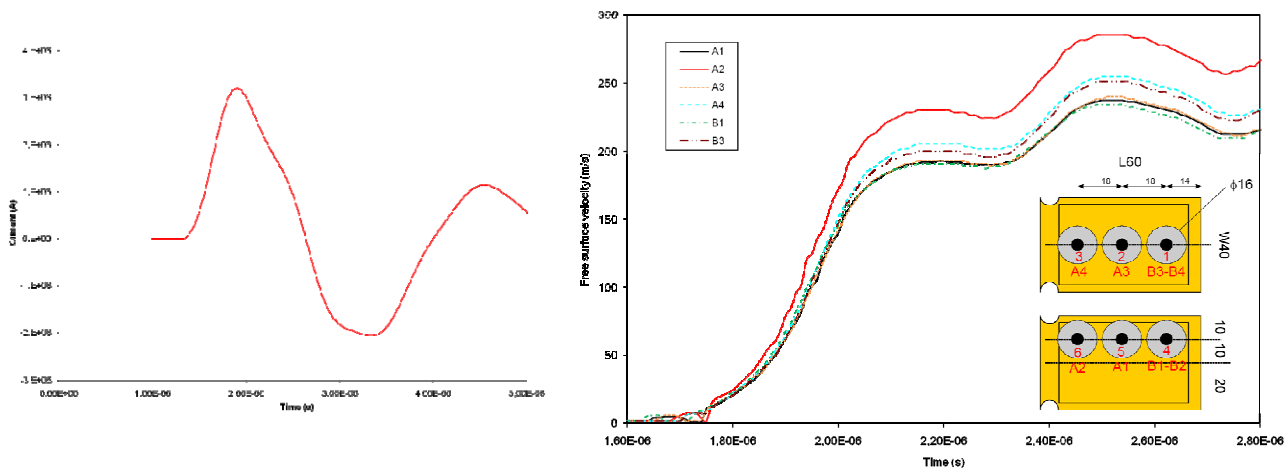

Figure 5 : GEPI shot 465 – Copper, $W= 40$ mm, $thick= 1$ mm – current measurement and free surface velocities.

The interferometer measurements show the following effects on the spatial repartition of the magnetic pressure:

i. Longitudinal direction

The notches lead to an important increase of the magnetic field on the axis then to a relatively fast decrease when going away from the notches (interferometers A4 and A3). The magnetic field is again strengthened, on the axis, near the short circuit. On the contrary, the free surface velocities measured at $\frac{1}{4}$ of the width indicate a decrease of the magnetic pressure behind the notches (lowering observed between interferometers A2 and A1). No pressure increase close to the short circuit is noted on this line (interferometers A1 and B1).

ii. Transversal direction

Only interferometers measurements located near the notches show an increase of the magnetic pressure when getting closer to the strip line external edge (interferometers A4 and A2). In the middle of the strip line, the pressure seems constant in the transversal direction (interferometers A3 and A1). On the other hand, the pressure decreases near the short circuit when moving away from the central axis (interferometers B3 and B1). It could possibly be explained by an inhomogeneous breakdown along the width of the short circuit. A Later improvement of the load has solved this problem.

The spatial free surface velocities distribution are presented Table I.

Table I : GEPI shot 465 - Spatial Free surface velocities repartition

Longitudinal direction				
central Axe			Axe (width/4)	
Distance (mm)	Interferometers	Relative difference	Interferometers	Relative difference
18	A4-A3	-6,42%	A2-A1	-16,39%
18	A3-B3	3,92%	A1-B1	-0,98%
36	A4-B3	-2,75%	A2-B1	-17,21%
Transversal direction				
	Interferometers	Relative difference		
« notches »	A4-A2	11,93%		
« half strip line »	A3-A1	0,00%		
« short circuit »	B3-B1	-4,72%		

We remind that the free surface velocities are strongly dependant on the magnetic pressure. Indeed, pressure and velocity follow the Rankine-Hugoniot relations [15]. So, the spatial pressure repartition is closely related to the spatial free surface distribution. Considering the differences presented in Table I, we expect the spatial distribution of the magnetic pressure to be rather inhomogeneous. We will try to explain these phenomena using LS-DYNA, as described now.

3.2 Numerical model

In order to limit the memory requirement of the Electromagnetism module, only the launcher is modeled with a relative fine mesh. Also, in order to avoid the time consuming recomputation of the EM matrices as the conductors move, we made the hypothesis that the spatial distribution of the pressure is the same at low current (with no motion of the conductors) as with the actual GEPI current.

A 3D mesh for the strip line is presented Figure 6. It is composed of 137 408 bricks elements with 8 elements through the thickness of the copper electrode (2 in the initial skin depth (about 0.1 mm) that tends to grow with the rise of the electrode temperature and then 6 for the rest of the electrode with a graded size). The mesh generates 40 336 BEM faces. Low rank approximations are made on the BEM matrices. The RAM needed is about 10 Go. A coupled mechanical / thermal / electromagnetism simulation has been performed even if there is no motion (the current is very low). The diffusion of the current through the thickness of the copper is taken into account. The electrical conductivity versus temperature and density is computed using a Burgess equation of state [10] (conductivity is temperature dependent with phase change). For the mechanical response, the Johnson-Cook model (*MAT_15) [9][8] coupled with the Gruneisen equation of state (*EOS_GRUNEISEN) were used. No phase change was taken into account in the mechanical equation of state and in the thermal model. The thermal model used is a very basic *MAT_THERMAL_ISOTROPIC [1] model. It allows to compute the temperature for the electrical and mechanical models essentially. The whole process is in effect very fast (600 nanoseconds) in comparison to the thermal propagation.

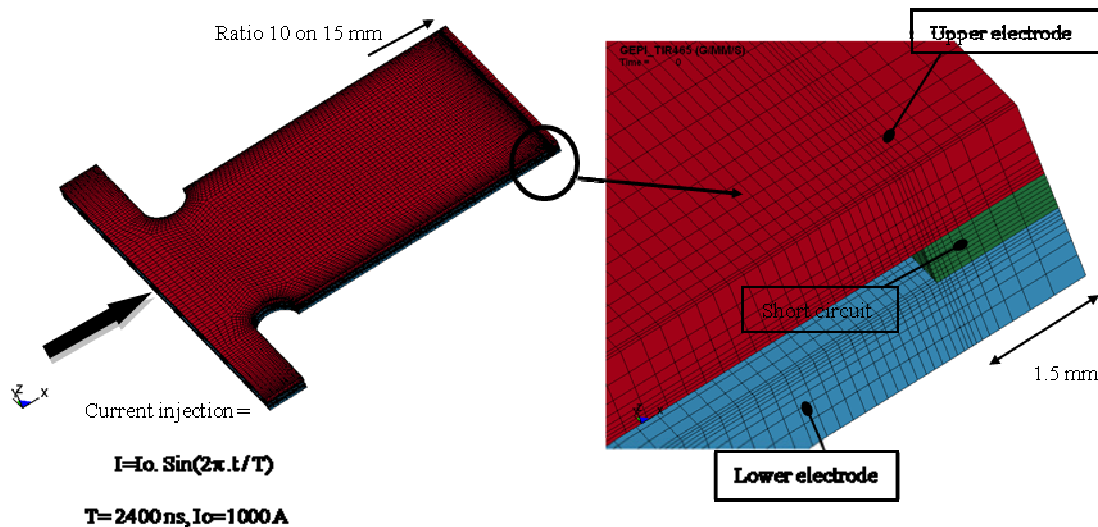

Figure 6 : LS-DYNA GEPI shot 465 – Numerical model.

In contrary to the experimental results, the spatial pressure distribution computed with LS-DYNA is very homogeneous (see Figures 7). The experimental velocities show an increase of the magnetic pressure near the short circuit where the velocity increases about 4% along the central axe (see Table I).

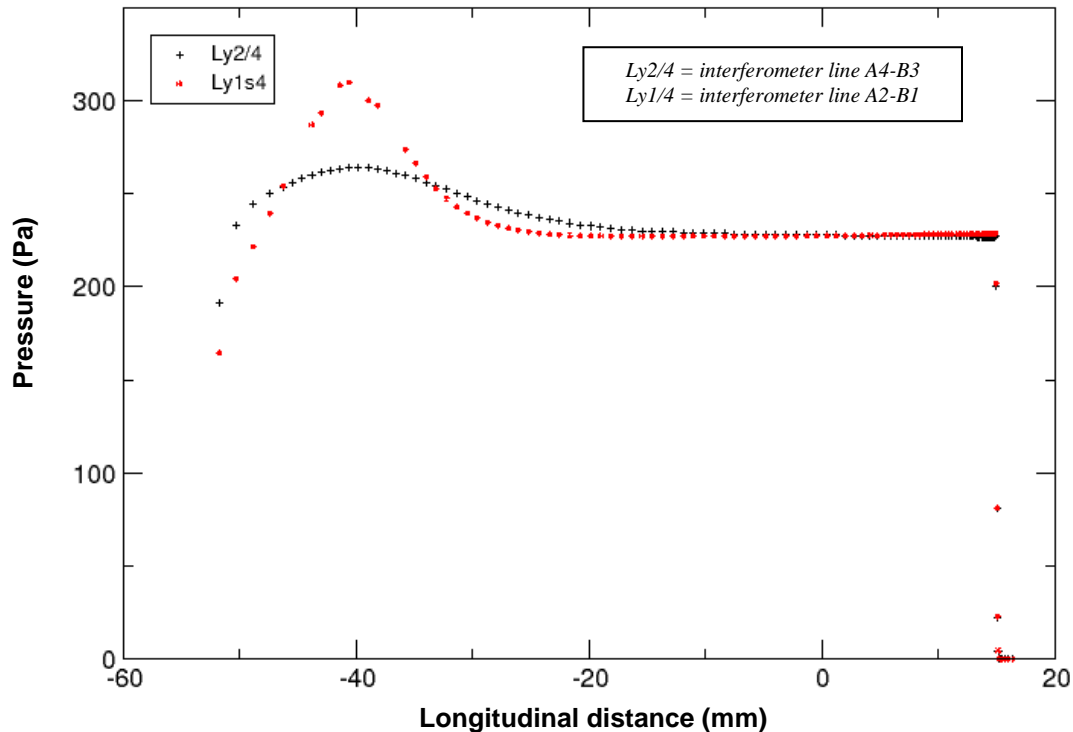

Figure 7 : LS-DYNA GEPI shot 465 – spatial pressure distribution [14].

The differences between the simulation and the experimental results could be explained by the 3 following hypotheses:

- i. During the experiment, the short circuit could be less large than the strip line because this is operated by a self breakdown. Furthermore a pinch effect could reduce the short circuit width during the pulse. These phenomena could explain the pressure increase along the strip line close to the short circuit.
- ii. The LS-DYNA model supposes that the current is quasi homogeneous at the entrance of the strip line which is probably not be the case in the experiment. Indeed the current may even be asymmetric due to the self breakdown making the short circuit.
- iii. The strip line deformation coupled with a small asymmetry (current and/or setting experiment) could generate a transversal dissymmetry.

Nevertheless, using this approach, the influence of the width of the short circuit has been studied by numerical simulations but will not be shown in this paper. We concluded that an improvement of the load design is first needed in order to show the ability of LS-DYNA to reproduce the measured free surface velocities.

3.3 Load design improvement

We thought that the current inhomogeneity in the real load was mainly due to the contacts defaults at the entrance of the strip line and in the short circuit made by a self breakdown between the upper and the lower electrodes. So first, in order to improve the contact upstream the strip line, we have enlarged the straight contact in Figure 4 to a circular one as in Figure 8 (top view).

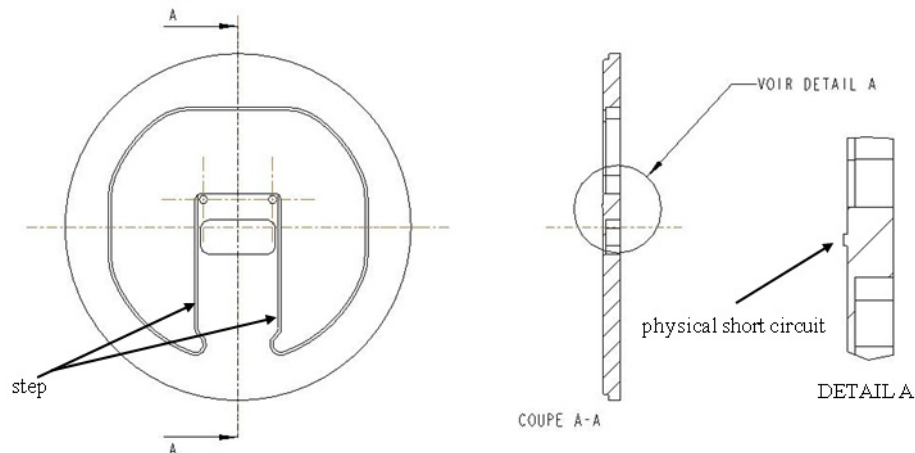

Figure 8 : GEPI shot 475 – new experiment setting.

Second, in order to improve the contact at the short circuit, a physical contact was made along the width instead of leaving the current arcing between the lower and the upper electrode make the short circuit (see Figure 8). The third improvement was to reduce the current flowing on the sides of the strip line (5% estimated). For this purpose a step was designed. The last improvement was to reduce the length of the strip line in order to limit its inductance.

4. Optimal GEPI electrode configuration (CEG - GEPI shot n°475)

4.1 Experimental configuration and results

As for shot 465, the free surface velocities have been analyzed for shot 475 and are presented in Figure 9. The Free surface velocities now are very homogeneous, representing a great improvement compared to shot n°465. The relative scatter is lower than 0.6% for shot n°475 versus 4.72 % for shot n°465. For shot 475, these scatters are measured close to the short circuit and near the edges. Hence, the magnetic pressure is very homogeneous, in the transversal direction, at 10 mm from short circuit.

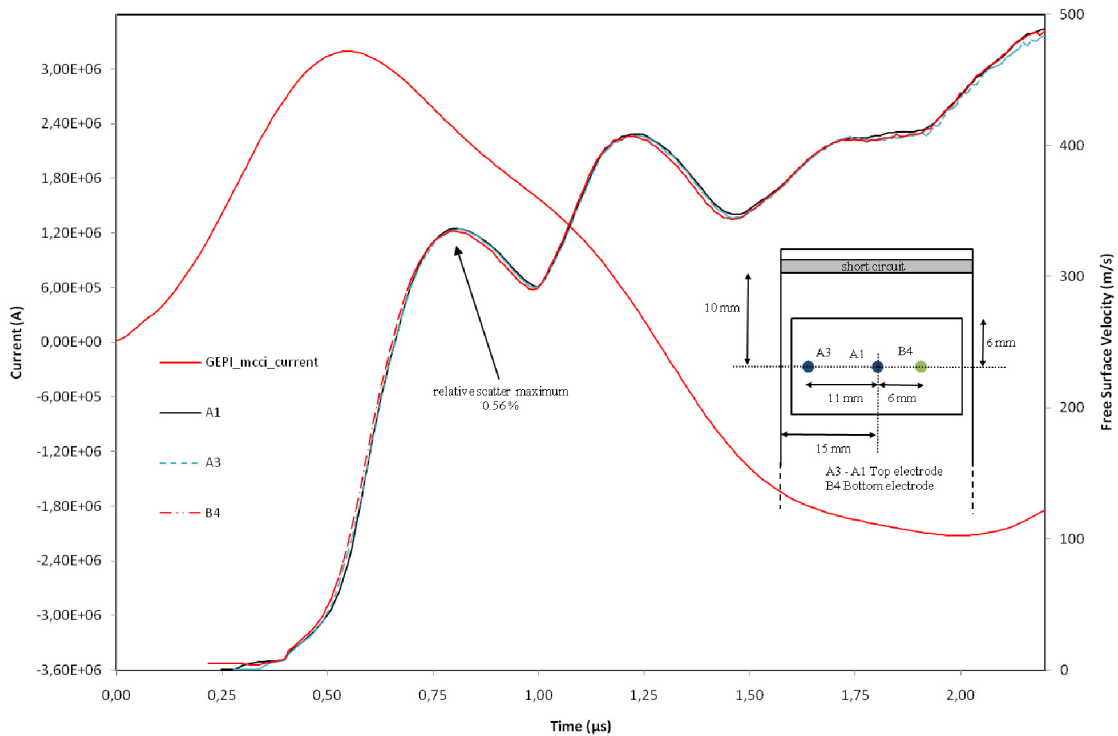

Figure 9 : GEPI shot 475 – Current and Free Surface Velocities (the relative scatter has been calculated on 5 spatially distributed measurements; for the clarity of the figure only 3 velocity profiles are presented).

We are going to try to reproduce these free surface velocities results using LS-DYNA coupled to its MHD routine.

4.2 Numerical model

The model is close to the one presented at paragraph 3.2. It was not possible to model the whole circular part due to the large number of cells and because for the moment, only a homogeneous current can be injected at the boundaries in LS-DYNA. The experimental current is injected at the straight entrance of the 1 mm thick launcher. The rest of the electrodes are modeled using only the thermal and mechanical solvers (see Figure 10). It means that the electromagnetic effects are taken into account only in the launcher. This should not influence the distribution of the magnetic pressure except near the lateral edges and the RAM cost become acceptable (about 8 Go) with a relative fine mesh (see Figure 10). The mesh is composed of 185 592 bricks elements and 15 elements through the thickness of the launcher (2 in the initial skin depth (about 0.1 mm) that tends to grow quickly with the rise of the electrode temperature and then 13 for the rest of the electrode with a ratio). This seems sufficient to handle correctly the magnetic diffusion as demonstrated in [8]. The update of the electromagnetism matrices is now necessary because strong mesh deformations occur. This update occurs each 5 electromagnetic cycles (30 ns).

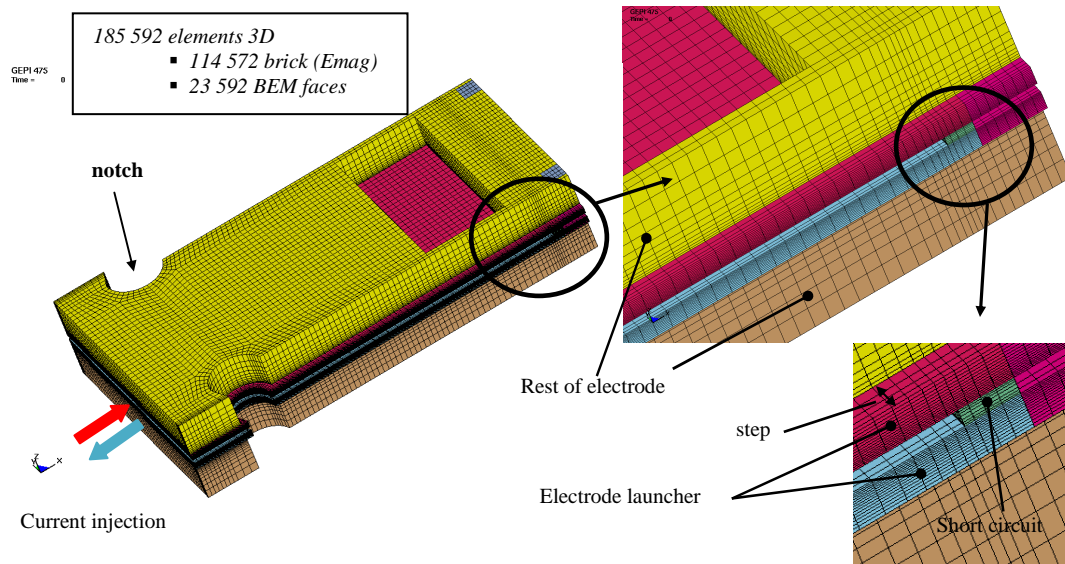

Figure 10 : LS-DYNA GEPI shot 475 – Numerical model.

The LS-DYNA free surface velocities are compared to the experimental ones below.

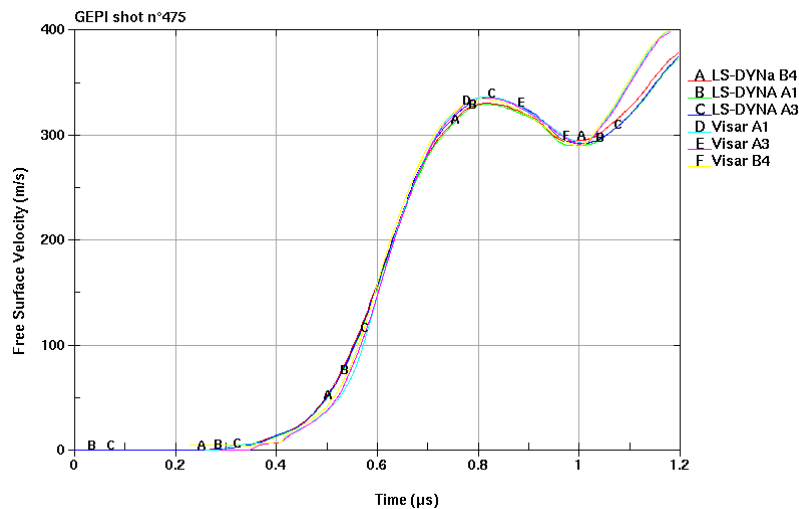

Figure 11 : LS-DYNA GEPI shot 475- copper, $W=30$ mm, thick=1 mm – Free surface velocities.

The simulations are done using the experimental current without any correction factor. The first velocity peak is just slightly below the experimental one (about -2%). The LS-DYNA model gives good prediction in the ramp compression phase despite small slope differences with the experiment (about 3 %).

This strip line geometry doesn't show any dissymmetry and the spatial distribution of the magnetic pressure is similar to the 465 GEPI shot model (see Figures 12 and 7). Hence, this kind of geometry allows to obtain an homogeneous pressure distribution in a large zone of the gap area (the pressure scatter is lower than 1% on large area representing 28 % of the strip line area). Furthermore, these geometry improvements allow to increase the free surface velocity. Indeed, for the GEPI shot n°410 (same width and thickness than the shot n°475), the free surface velocity is about 280 m/s only compare to 336 m/s for the shot n°475. The experiment setting is the same that the shot 465 (see Figure 4).

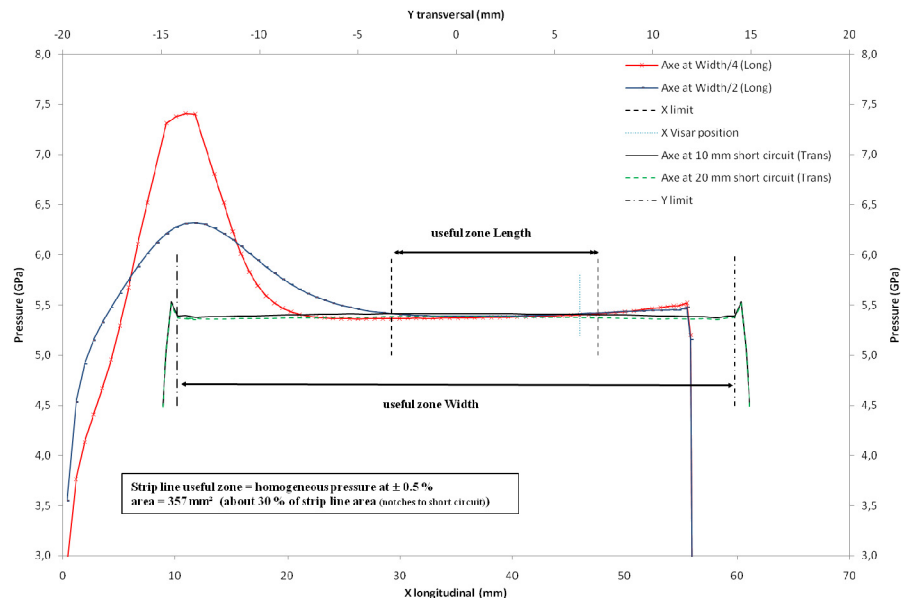

Figure 12 : LS-DYNA GEPI shot 475 – Spatial distribution of magnetic pressure.

After the compression ramp phase, the numerical velocity oscillations don't reproduce very well the experimental velocity. These differences could be explained as follow:

- i. Current injection: The numerical one can't be perfectly similar to the real current in the strip line. Firstly because the MCCI average current is accurate to a few percents only. Obviously, a better current injection would reduce the difference in the maximal velocity between experimental and numerical results. Furthermore, the spatial current distribution could also be different. To avoid it, a larger model with the boundary condition defining the current injection far away enough from the strip line could be helpful. But at present it is not possible to define a complete GEPI model (RAM and CPU cost). However, LSTC will soon develop a new current boundary condition. This new boundary will allow a spatial current distribution at the entrance of the mesh presented Figure 10. This distribution can be deduced from 2D full consistent circuit simulations [12] fitting well all the twelve experimental MCCI.
- ii. Materials models: The electrical model takes into account phase transitions using Burgess equation of state. However, the thermal and mechanical (equation of state) models don't take into account phase transitions. Since the temperature in the gap is over melting temperature, these should be taken into account. Some user's materials laws are going to be developed in the next future by ITHPP in order to allow a more accurate modeling of high energy densities like in these GEPI experiments.

5. Conclusion

LS-DYNA is a good tool to understand complex coupled mechanisms, such as GEPI shot. The Numerical velocities reproduce rather correctly the experimental measurements. Furthermore, GEPI shot and LS-DYNA indicate that the spatial distribution of the magnetic pressure is very homogeneous in a large gap area. So, the last GEPI configuration tested seems to be rather good. New experiments are planned to confirm the advantages of this configuration. Obviously, LS-DYNA could be used to define other strip lines geometries at even higher

pressure. However, coherent coupled material models are necessary. These kinds of models are going to be developed by ITHPP as a user's material law. This work has been supported by DGA/DET/CEG.

References

- [1] "LS-DYNA[®] Keyword User's Manual Version 971" – LSTC – May 2007.
- [2] "LS-DYNA[®] Theory Manual" – LSTC compiled by John O. Hallquist – March 2006.
- [3] "GEPI : An ICE Generator for Dynamic Material characterization and Hypervelocity Impact" – P. L. Héreil, F. Lassalle and Gilles Avrillaud – Shock Compression of Condensed Matter - 2003.
- [4] "GEPI : an ICE generator for dynamic material studies"- P.L. Héreil and G. Avrillaud - Presentation for the 55th Meeting of the Aeroballistic Range Association (ARA), Freiburg, Germany, September 27-October 1, 2004.
- [5] "Isentropic Compression in a Strip Line, Numerical Simulation and Comparison with GEPI Shot 268" – A. Lefrançois, P. L'Eplattenier and M. Burger – Lawrence Livermore National Laboratory UCRL-TR-219179 – February 2006.
- [6] "Introduction of an Electromagnetism Module in LS-DYNA for Coupled Mechanical-Thermal-Electromagnetic Simulations" – P. L'Eplattenier, G. Cook, C. Ashcraft, M. Burger, A. Shapiro, G. Daehn and M. Seth – 9th International LS-DYNA Users Conference – 2004.
- [7] "Introduction of an Electromagnetism Module in LS-DYNA for Coupled Mechanical-Thermal-Electromagnetic Simulations" – P. L'Eplattenier, G. Cook, C. Ashcraft – 3th International Conference on High Speed Forming – 2008. "LS-DYNA[®] Keyword User's Manual Version 971" – LSTC – May 2007.
- [8] "Introduction of an Electromagnetism Module in LS-DYNA for Coupled Mechanical-Thermal-Electromagnetic Simulations" – P. L'Eplattenier, G. Cook, C. Ashcraft, M. Burger, A. Shapiro, – LSTC internal report available at ftp.lstc.com/outgoing2/ls980_beta/Electromagnetism/documentation/talk_class.ppt
- [9] "A constitutive model and data for Metals Subjected to large Strains, High Strain rates and High Temperatures" – G. R. Johnson, W. H. Cook – Proc 7th Int. symp. on Ballistics, The Hague, The Netherlands – April 1983.
- [10] "Electrical Resistivity Model of Metal" – T. J. Burgess – 4th international conference on megagauss magnetic-field generation and related topics - July 1986. "LS-DYNA[®] Keyword User's Manual Version 971" – LSTC – May 2007.
- [11] "Pulsed High Magnetic Fields" – H. Knoepfel –NHPC – 1970. "LS-DYNA[®] Keyword User's Manual Version 971" – LSTC – May 2007.
- [12] "ITHPP report n° RA3-P3-OP17-IS06345" – G. Avrillaud – December 2007 (CEG, not publicly available)
- [13] "ITHPP report n° RA4-P3-OP17-IS06345" – P. Laporte – December 2007 (CEG, not publicly available).
- [14] "ITHPP report n° RS-P3-OP17-IS06345" – G. Le Blanc – December 2007 (CEG, not publicly available).
- [15] "Dynamic Behavior of Materials" – Marc André Meyers – 1994.