

Thermal-Structure Coupling Simulation Analysis on Rolling Process of H-shape Steel

Zhiyuan Shi

Chief CAE Specialist,
ShouGang Steel Group
Beijing P. R. China
Ivan_szy@yahoo.com.cn

Guoming Zhu

University of Science and Technology Beijing
zhuguoming345@yahoo.com.cn

Abstract

Today CAE technology is seeing its rapid development and got widely application in nearly all industries. For metallurgy CAE is also becoming the highlight in many specialties and playing important roles in process optimization and property prediction for R&D of new product development. In this paper a typical example, i.e. thermal-structure coupling simulation analysis on rolling process of H-shape steel with LS-DYNA is introduced.

Key words: H-shape steel, Rolling Process, Simulation, Thermal-structure coupling, LS-DYNA

Preface

At present, it is somewhat difficult to monitor cross-section temperature field distribution of the whole work-piece by experimental approaches in H-shape steel production. At the meantime, CAE method is seeing rapid development in nearly all industries including metallurgy. In this paper the rolling process of H-shape steel is simulated with three-dimension elasto-plasticity FE method with consideration of thermal coupling, and the deformation behavior of work-piece as well as temperature field distribution are obtained.

LS-DYNA is a famous explicit code including implicit function from LSTC, it is very much strong in the analysis of metal forming, blast, drop test, crashworthiness, material failure prediction, etc. offering both traditional methods such as Lagrange, ALE and Euler and the latest technologies such as SPH and EFG. Moreover, LS-DYNA provides high-efficiency parallel computation technology like SMP and MPP, the later seems much more attractive and effective for super model.

Modeling

The 3D CAD model is shown in figure 1 and the continuous casting shaped bloom is used in H-shape steel production, see figure 2 for the cross section of product. For symmetry it is simplified as one quarter of the section. Taking 500mm-long bloom along the rolling direction as original reference model, the FE mesh of bloom is shown in figure 3. The rollers are simplified as rigid and then dispersed only on exterior surface with triangle meshes. The whole FE model for the first pass is shown in figure 4.

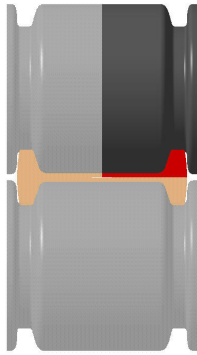

Figure 1 CAD model (3D)

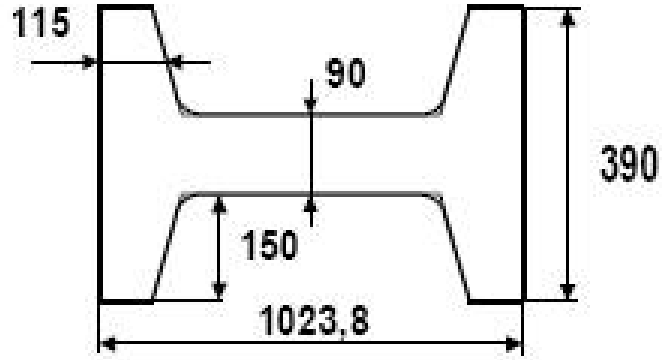

Figure 2 Cross section of shaped bloom

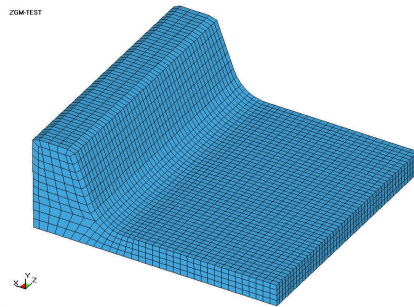

Figure 3 FE model of bloom

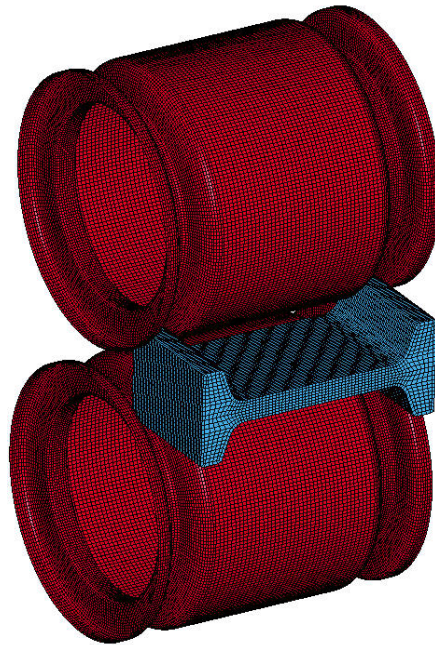

Figure 4 The whole FE model for the first pass

Boundary conditions, material model and loads

The elasto-plasticity three-dimension FEM with thermal-structure coupling is used in the rolling process in order to predict the deformation and temperature distribution of rolled piece. Some parameters are listed as follows,

Original temperature: 1200□

Material of bloom: Q235 (low carbon steel), Elasto-plastic.

Roller: rigid body. The temperature of roller is about 300□ and kept constant during calculation.

The heat transfer coefficient between roller and piece is valued as 20 kW/ (m²·K).

The reduction of H-shape steel is quite large during rolling process leading to temperature ascending of rolled piece. When calculating temperature distribution during rolling process, it is necessary to consider the contribution of plastic work to heat energy. In this research, it is assumed that plastic work done transformed to heat energy completely.

Calculation and results

According to the pass schedule, the whole rolling process is simulated and the calculation principle is to calculate every pass separately and the original condition is the result of former pass. The calculation content consists of every pass deformation and the three-dimension temperature distribution of the rolled piece.









No.	Sta.	Groove No.	Dimension mm	dh mm	Work Gap mm	Force kN	Area		Length m	Torque kNm	work. Dia. mm	Speed m/s	RPM 1/min	Roll Time s	Dead Time s
							mm ²	Red. %							
1		1/C	 140		138	3039	160329	1,5	12,6	200	958	2	39,87	6,8	120,4
2		1/C	 85	5	83	5190	154145	3,9	13,1	467	1018	2,2	41,27	6,4	5
3		1/C	 70	15	68	7669	138635	10,1	14,5	1090	1018	2,4	45,03	6,6	5
4		1/C	 58	12	56	7484	126155	9,0	16,0	1021	1018	2,6	48,78	6,6	5
5		1/C	 49	9	47	6959	116741	7,5	17,3	831	1018	2,8	52,53	6,7	5
6	BD 1	1/C	 42	7	40	6687	109391	6,3	18,4	718	1018	3	56,28	6,6	5
7		2/B	 65		63	4834	107960	1,3	18,7	678	959	2,8	55,76	7,2	7
8		2/B	 42		40	4161	106880	1,0	18,9	553	1023	3,2	59,74	6,4	5
9		3/A	 42		40	3949	105811	1,0	19,0	531	1024	3,2	59,68	6,5	7

Table 1 pass schedule for BD mills

It is calculated several times during cogging process of BD rolling mill according to the eighteen units in table below. Where, C is the cooling coefficient during pass interval.

Pass number	BD1		BD2		BD3		BD4		BD5	
Calculation unit	R	C	R	C	R	C	R	C	R	C
Pass number	BD6		BD7		BD8		BD9			
Calculation unit	R	C	R	C	R	C	R	C		

Table 2 Calculation units for BD mills

The following contours show the temperature and stress results in every pass for BD mills.

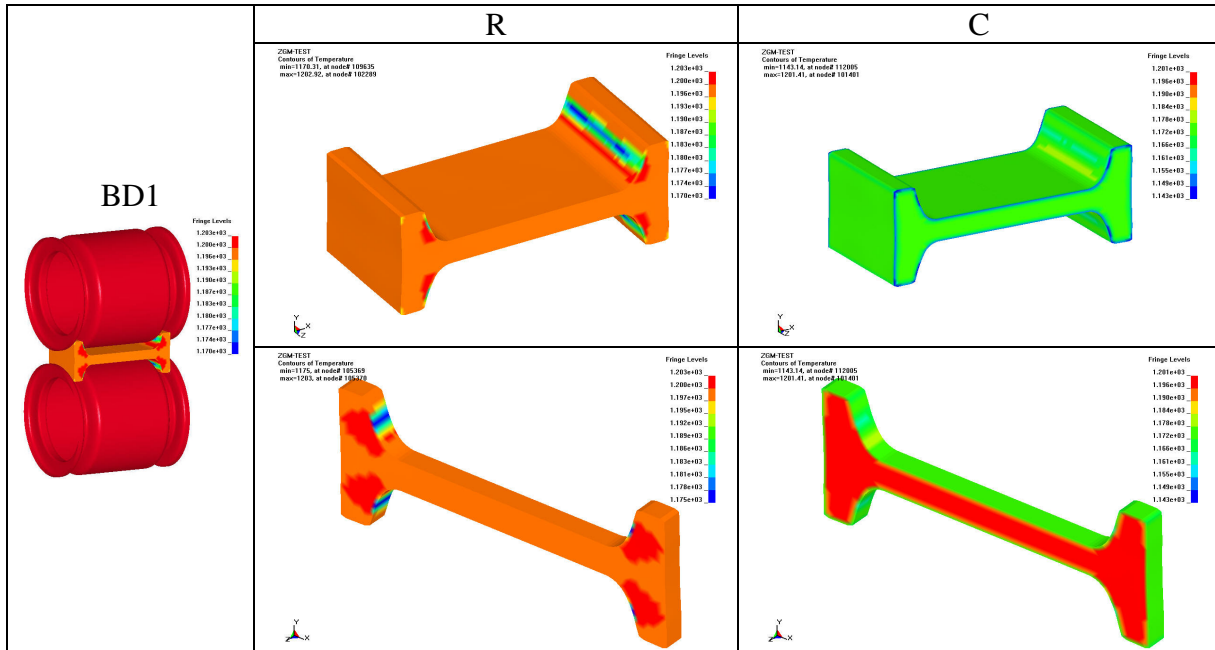

Figure 5 Simulation results for BD1

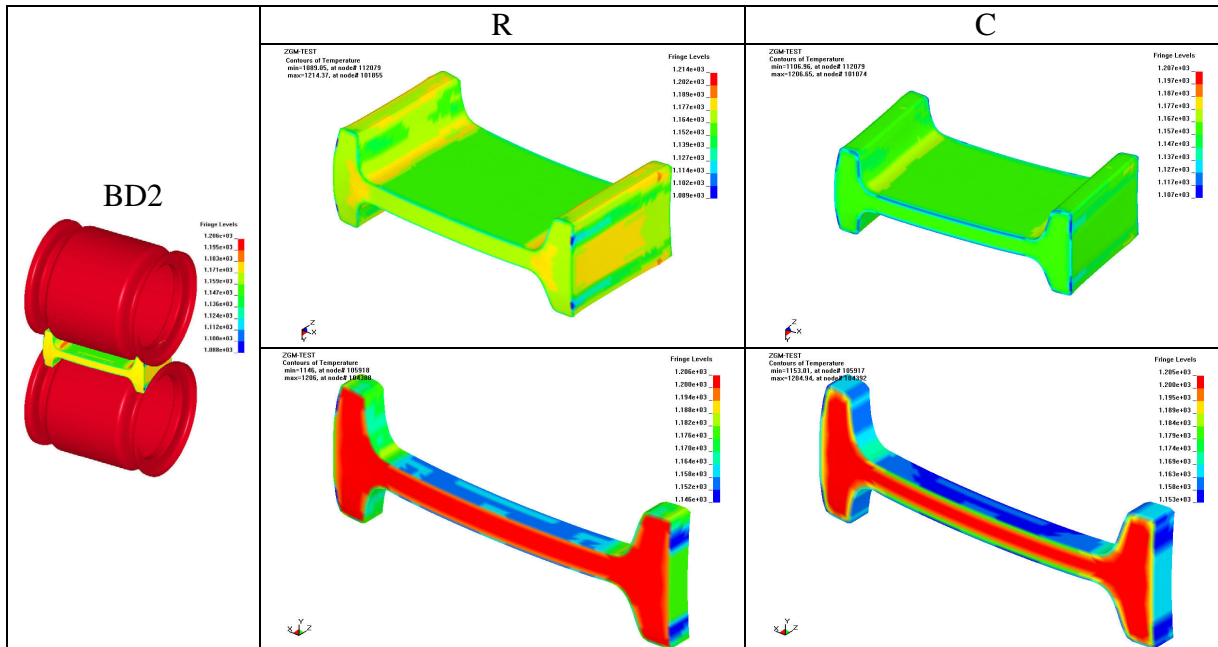

Figure 6 Simulation results for BD2

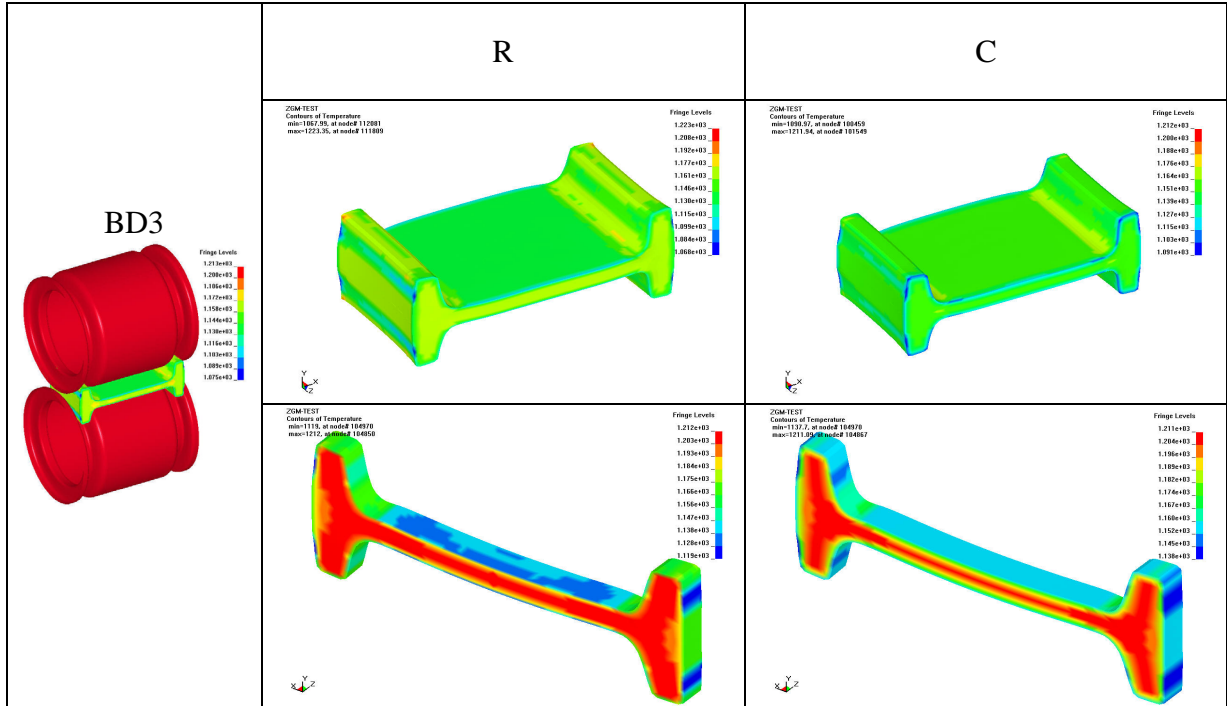

Figure 7 Simulation results for BD3

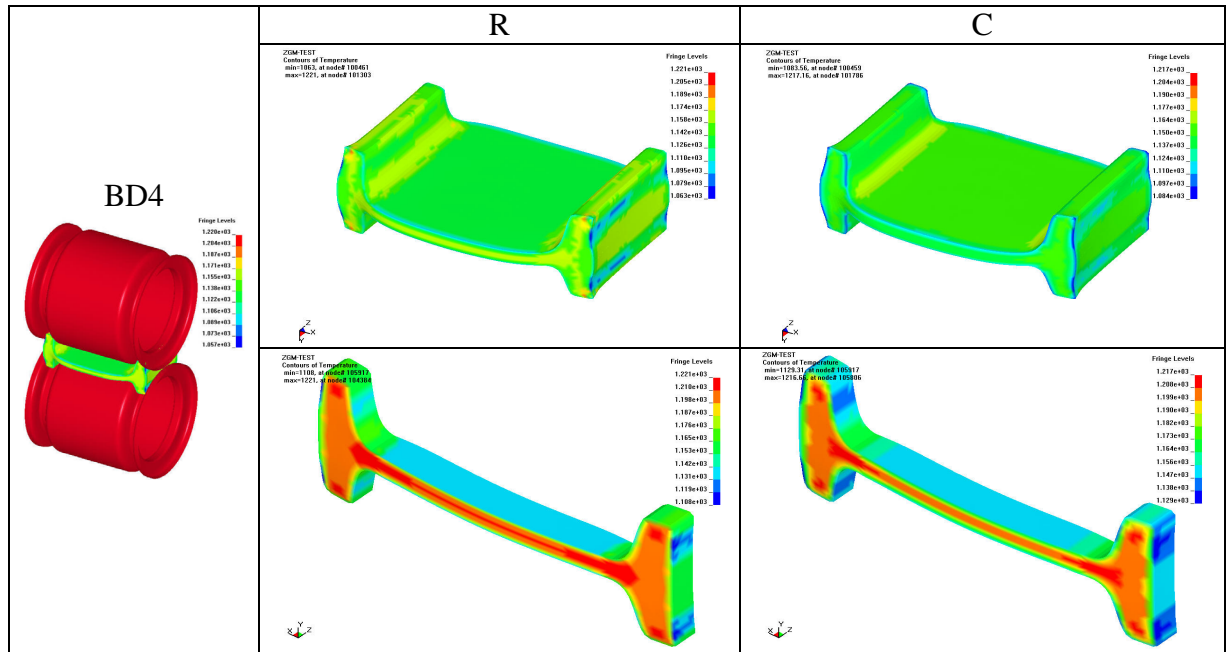

Figure 8 Simulation results for BD4

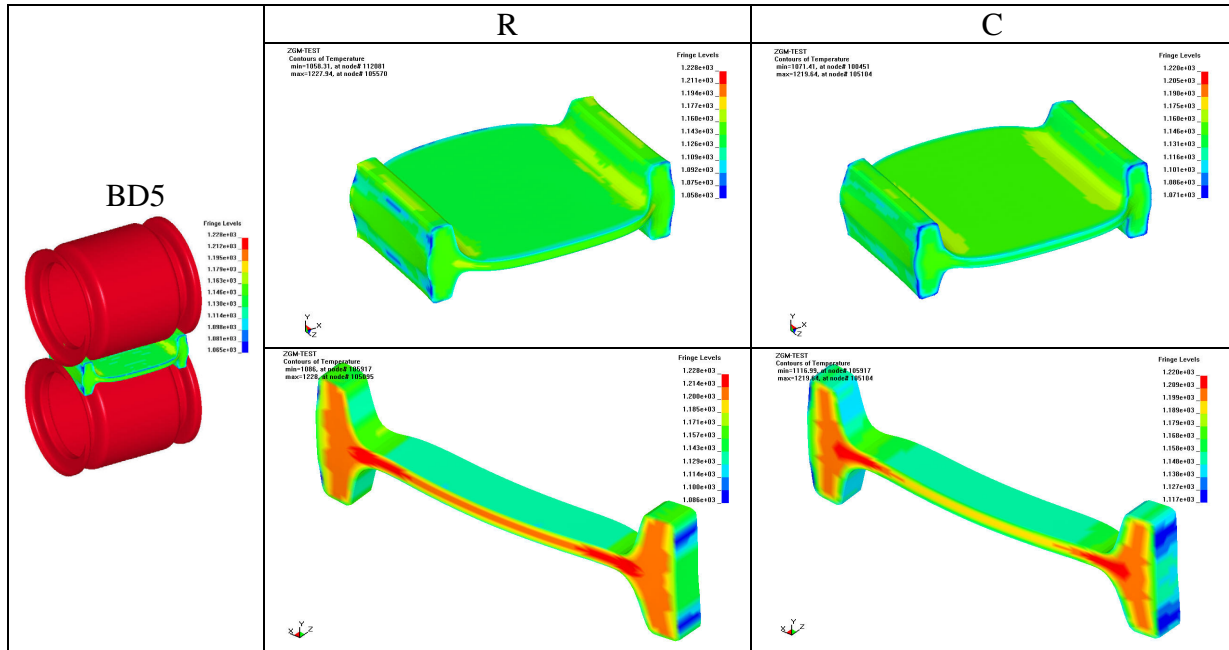

Figure 9 Simulation results for BD5

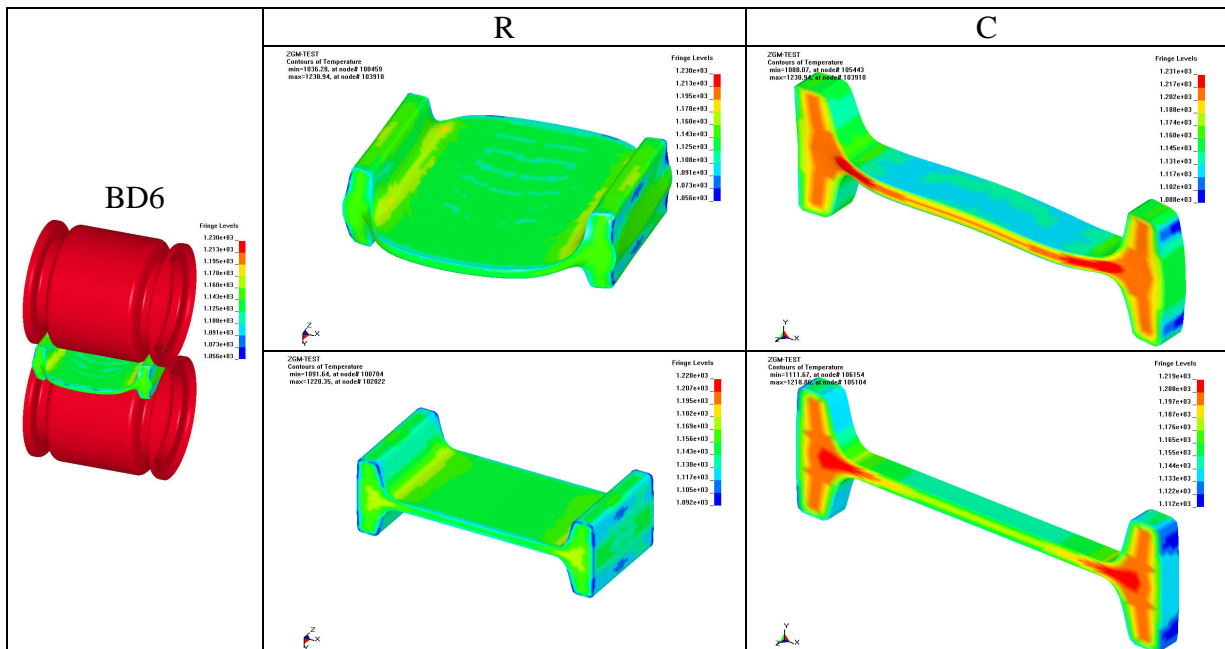

Figure 10 Simulation results for BD6

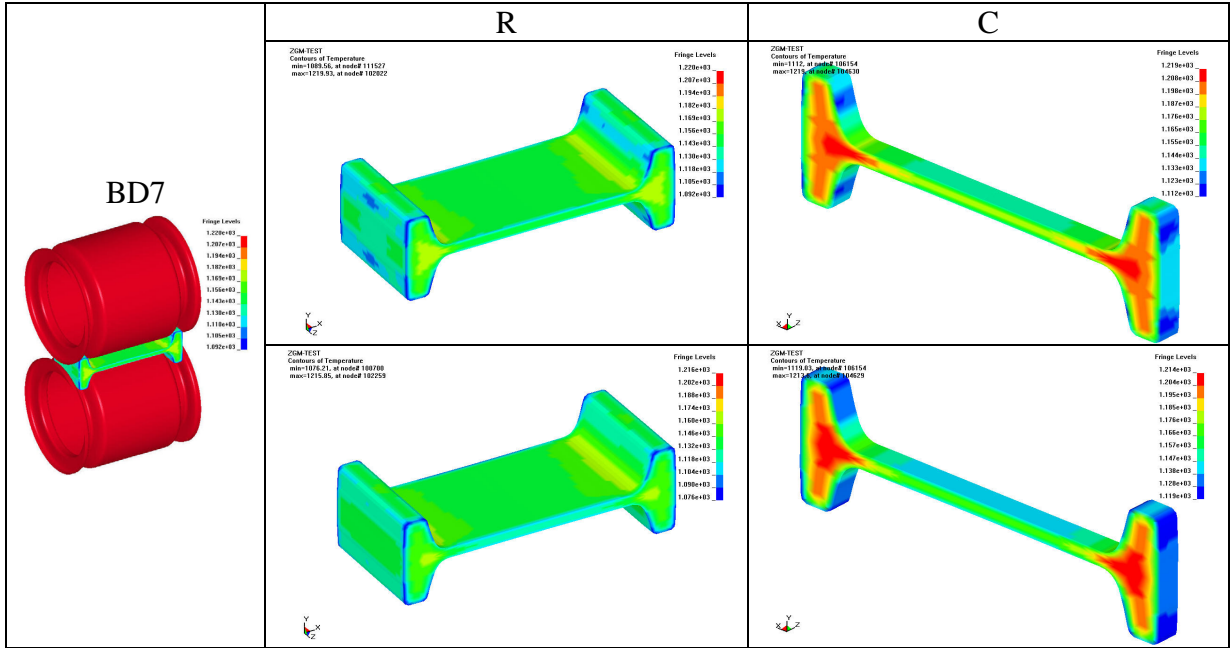

Figure 11 Simulation results for BD7

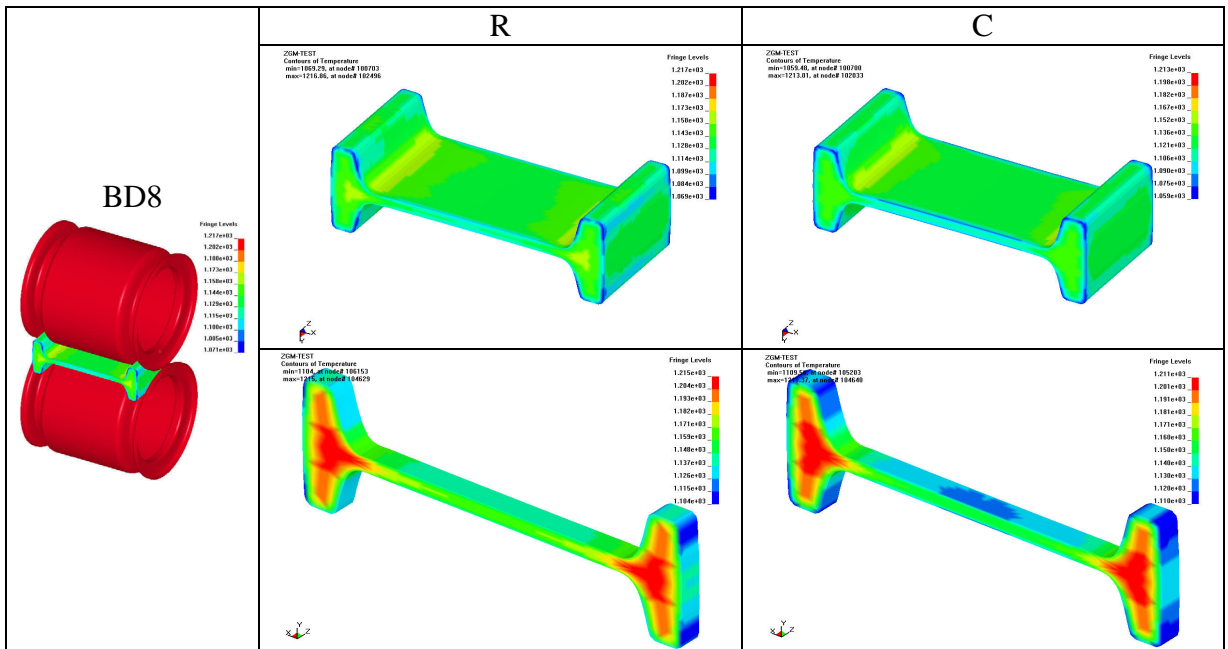

Figure 12 Simulation results for BD8

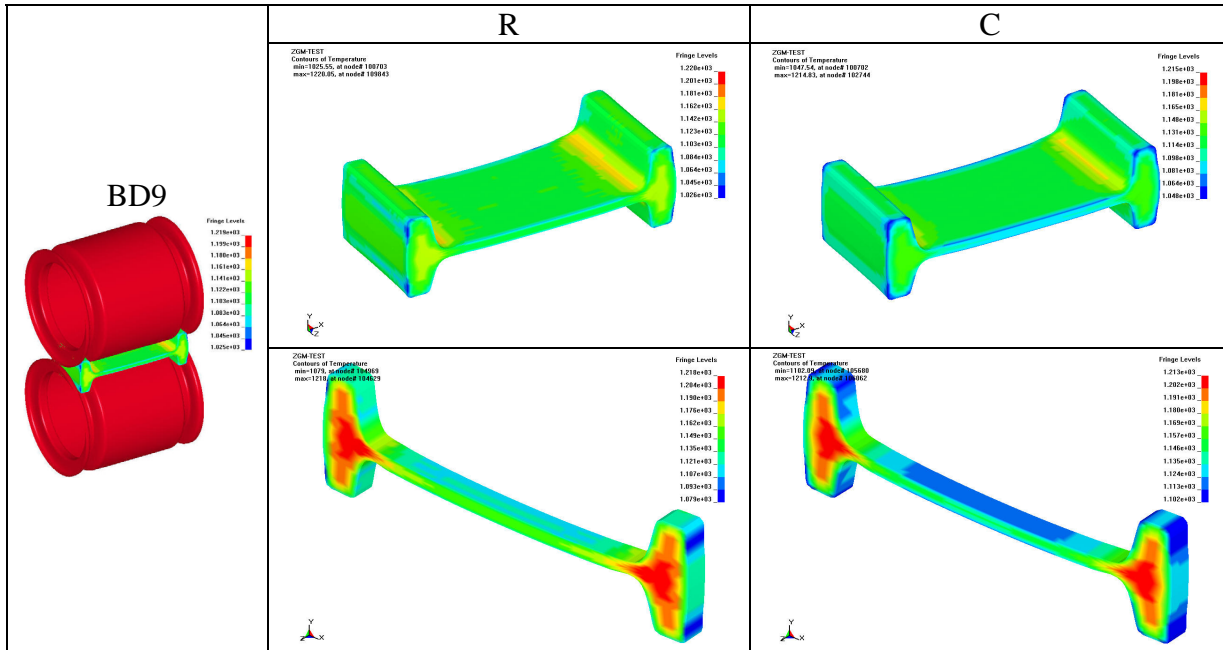

Figure 13 Simulation results for BD9

Discussion of BD result

Analysis of deformation result

The cross-section after deformation is abstracted from the every pass calculation result of BD rolling mill and piled up, referring to figure14 and figure15.

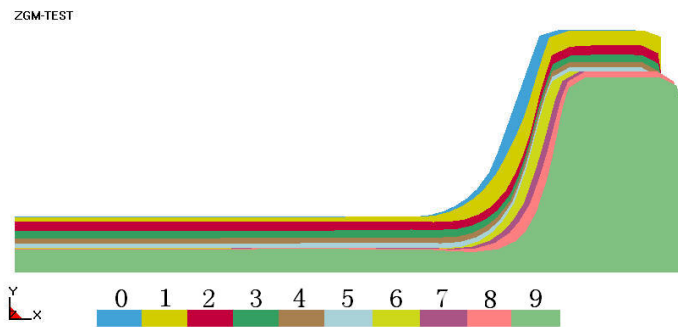

Figure 14 Comparison of exit profiles for each passes

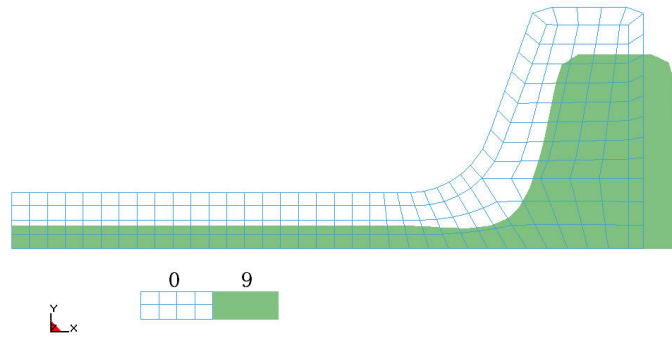

Figure 15 Cross-Section Comparison between original bloom and final product profile
In those figures above, 0 means the profile of the ingot cross-section, 1 means the profile of the rolled piece after the one pass in stable stage, and so on.

And we have the following conclusions from above analysis:

- During rolling process, the reduction of web plate is quite big while the reduction of flange plate is almost invariable.
- The big reduction and extend result in the phenomena ‘tongue’ at web plate.
- The metal deformation is very great at R position, and it is difficult for heat to dissipate because of large thickness. A great deal of plastic work transformed to heat energy and the temperature ascended along with continuous accumulated reduction.
- The surface of rolled piece exposes to the air, so the surface temperature will fall first because of dissipate through radiation and convection.
- In deformed area, the temperature of the rolled piece surface contacting to the roller falls very greatly. The main reason is that the roller’s temperature is fairly low and heat exchange is then occurred between them.

Temperature track of the key points

The temperature of key points shown in figure 15 is tracked.

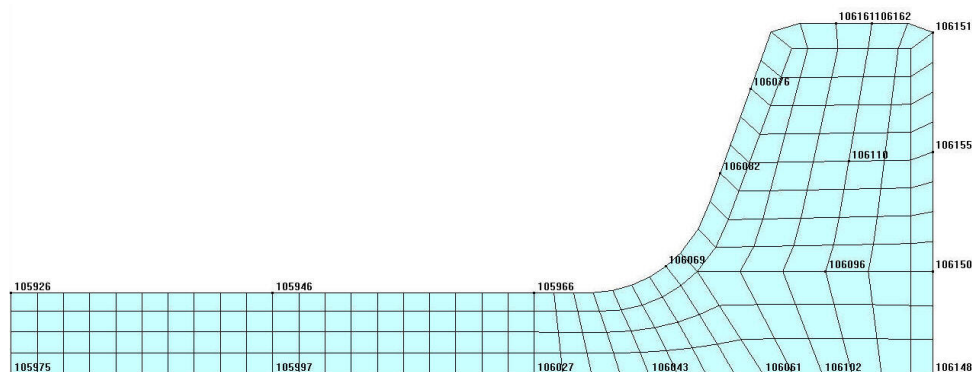

Figure 16 Selected key points on cross section

Figures 17-20 show temperature change of key points during rolling process of BD rolling mill.

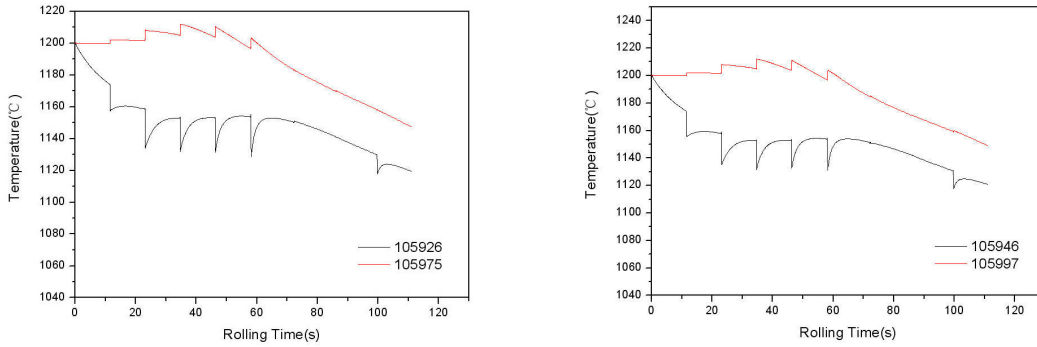

Figure 17 Temperature changes of key points 105926,105975,105946 and 105997

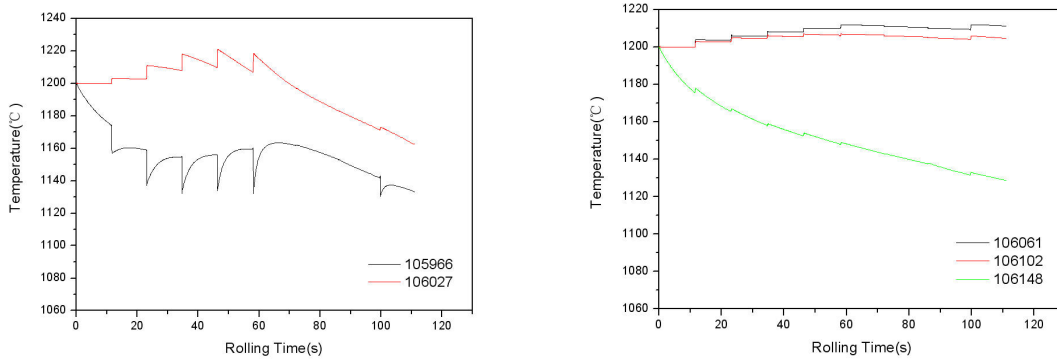

Figure 18 Temperature changes of key points 105966,106027,106061,106102 and 106148

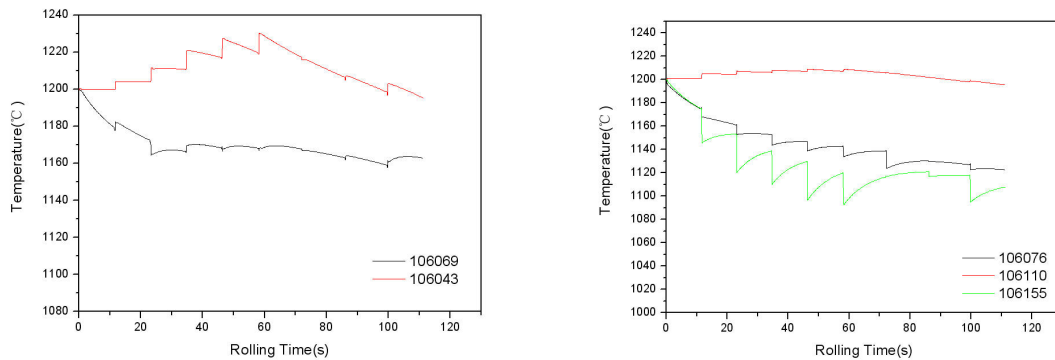

Figure 19 Temperature changes of key points 106069,106043,106075,106110 and 106155

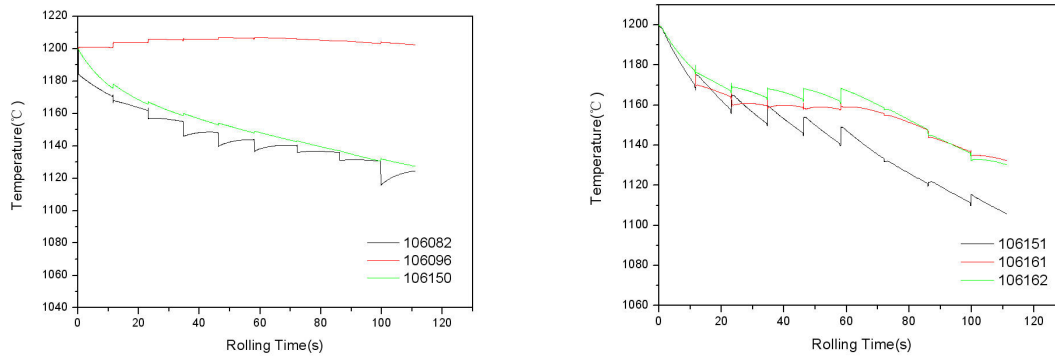

Figure 20 Temperature changes of key points 106082,106096,106150,106151,106161 and 106162

After analyzing temperature change of key points during cogging process in depth, we have the conclusion as follows,

- Temperature on key points on the surface falls rapidly when the rolled piece contacts the roller, and the drop of the temperature is great during contact time.
- Key points temperature in rolled piece ascend and the situation is opposite.
- Temperature distribution on cross-section shows trend of dropping, but only a few points temperature shows trend of ascending.
- The metal temperature of the flange plate center and the R position always shows a ascend current, and finishing temperature is higher than the original value.

References

- [1] ZHU Guo ming, WU Di, ZHAO Xian ming, Four pass cogging simulation of H beam by FEM, Journal of Materials and Metallurgy [J], Vol.1, No.3, Sept. 2002
- [2] Shapiro, A. B., Heat Transfer in LS-DYNA,4 European LS-DYNA Conference,Ulm,2003
- [3] Shapiro, A. B., Using LS-DYNA for Heat Transfer & Coupled Thermal-Stress Problem, LSTC Tutorial, 2004
- [4] LS-DYNA Thermal Analysis User Guide, LSTC, 1999

