

## A New Impact Scenario for P-V Tram Certification

### Authors

Marco ANGHILERI \*  
Luigi-M L CASTELLETTI \*  
Matteo PIROLA \*  
Fabio PISTOCHINI \*  
and  
Stefano RAITI \*\*

### Affiliations

\* Politecnico di Milano, Department of Aerospace Engineering  
Via La Masa 34, 20156 Milano, Italia

\*\* AnsaldoBreda, Engineering division  
Via Ciliegiole, 51100 Pistoia, Italia

### Correspondence

Luigi-M L CASTELLETTI, PhD  
Phone: +39.02.2399.7155, FAX: +39.02.2399.7153  
E-mail: [luigi.castelletti@polimi.it](mailto:luigi.castelletti@polimi.it)

### ABSTRACT

Tram crashworthiness is getting a more and more demanding issue. Simulations carried out to verify that the new tram AnsaldoBreda Sirio-Milano fulfils the prEN 15227 requirements for certification are here described. Besides a new impact scenario with characteristics closer to trams accidents is proposed. Structural enhancements so that the tram fulfils also the more severe impact condition of the new scenario are introduced.

### Keywords:

Tram Crashworthiness, Impact Scenarios for Tram Certification

## INTRODUCTION

Every year in Italy, the number of accidents involving public transport vehicles running on rails (commonly called *tram*) is around five hundreds. Most of the accidents involve private cars and pedestrians. The remaining are the consequence of sudden brakings and crashes between trams [1-3].

Crashworthiness requirements for railway vehicles (including trams) are collected in the European Standard prEN 15227. The railway vehicles are classified into five classes and for each one of these classes a number of different impact scenarios are defined.

In this work, the crash behaviour of a P-V class tram, the AnsaldoBreda Sirio-Milano, is numerically investigated. For the trams which fall in P-V class, three different impact scenarios are depicted in the prEN 15227. For each one of these scenarios, requirements on maximum accelerations and structural deformations are established in order to guarantee passengers' and driver's safety.

A numerical model of the tram structure is worked out and the three impact scenarios described in prEN 15227 are considered.

Referring to the accident described in the statistics [1-3], it was noticed that these scenarios are inadequate in some respects. In particular, the typical velocity of a tram approaching a tram-stop or a railway switch is higher than the ones prescribed in prEN15227. In view of that, a new scenario (derived from scenario #1) is here introduced: the impact of the tram with a rigid wall at the velocity of 15 km/h.

The new scenario, called scenario #4, is actually more severe than the ones in the prEN 15227. Simulations showed that a failure in the tram chassis structure brings to an unacceptable reduction in the driver's survival space – which is likely to cause severe injuries to the driver.

Three structural enhancements were hence introduced to assess the crash behaviour of the tram: a wider reinforcement connection in frontal zone, two closed section beams in driver seat support, and a new energy absorption device between the frontal bumper and the chassis. As a result the tram succeeded to match the requirements for new scenario.

## NUMERICAL MODEL

The FE model of the tram consists of five parts: the chassis, the three bogies, the frontal buffer, the frontal coupler and the frontal body (Fig. 1).

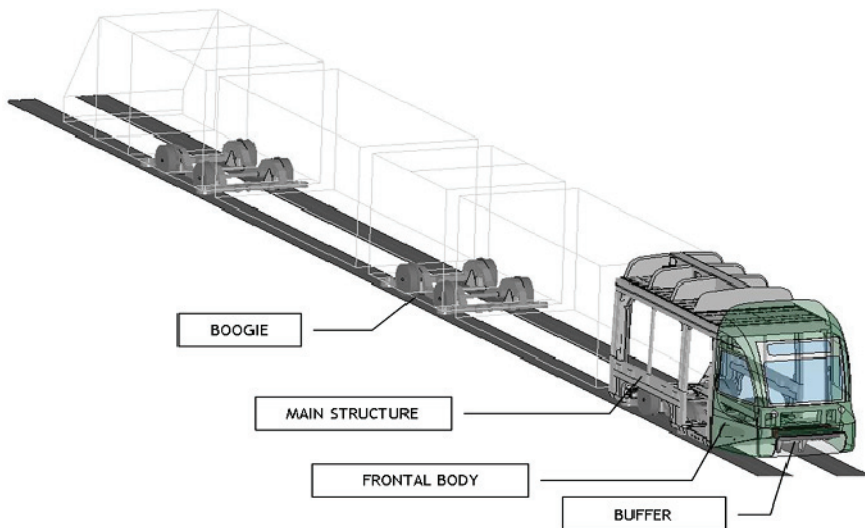

Figure 1: Numerical model of the AnsaldoBreda Sirio-Milano tram.

**Chassis.** The chassis was modelled with shell and beam elements. Lumped masses were also added to reproduce the inertial characteristics of the physical tram. Indeed, only the first coach was modelled in detail because only the first coach is involved in the impact. The remaining parts in the chassis were modelled with beam elements and lumped masses.

**Frontal buffer.** The frontal buffer is a primary energy absorption device for the tram. The structure was modelled with shell elements and assumed to be rigid. The dampers which join the frontal coach to the buffer and guarantee the impact energy absorption were modelled using discrete beam elements. In effort to accurately describe the actual energy absorption mechanism, the load curve of the physical buffer was used to characterize the crash behaviour of the two discrete beam elements.

**Boogies.** The boogies are central for the impact dynamics. The kinematics of the suspensions and the rail-wheel interaction is introduced in the numerical model through the boogies model. The boogies were assumed to be rigid (because massive and not directly involved in the impact) and modelled using shell elements. The suspensions were modelled using cylindrical joints and discrete beam elements – for which the actual stiffness and damping curves of the suspensions was used.

**Rails.** In order to provide a faithful representation of the tram dynamics and to capture potential tram derailments, it is important to accurately model the rail-wheel interaction. In view of that, not only the wheels but also the rail were modelled in detail.

**Frontal coupler.** The contribution of the frontal coupler to energy absorption is negligible and, therefore, it was not modelled with great detail. Indeed, the bolted joint with the tram chassis was modelled using four beams for which a failure criterion was defined in order to reproduce the detachment of the frontal coupler during the impact.

**Tram body.** The tram body is made with fibreglass and it has no relevant structural functions. Nevertheless, the frontal body was modelled in detail in view of further investigations regarding the safety of pedestrian hit by the tram [10].

## prEN 15227 SCENARIOS

As previously mentioned, for the trams which fall in P-V class, three different impact scenarios are depicted in the prEN 15227:

1. a front-end impact between two identical trams at 15 km/h
2. a front-end impact into a 55 tons freight vehicle at 10 km/h
3. a front impact into a 3 tons road-crossing obstacle placed on the railway at 25 km/h with an incidence of 45 deg

Numerical models of these impact scenarios were worked out and simulations carried out. The results obtained (described in detail in [9]) demonstrated that for each one of these scenarios, the requirements on maximum accelerations and structural deformations establish by the standards for passengers' and driver's safety are fully satisfied.

## A NEW IMPACT SCENARIO

After revising the accident statistics [1-3], it was noticed that the velocity of a tram approaching a tram-stop or a railway-switch is higher than one in prEN 15227 scenarios. In view of that, it was decided to introduce a new impact scenario based on scenario #1. This scenario, called scenario #4, prescribes the impact of the tram against a rigid wall at 15 km/h – which is the typical velocity recorded in the statistics of the tram-vs-tram accidents.

Even if the initial kinetic energy of the tram in scenario #4 is lower than the one in scenario #3, the impact conditions are more severe because the obstacle is rigid and fixed in the space. Accordingly, the new scenario is likely to become the benchmark test to find the higher damage level for the tram structure.

In the first simulations of scenario #4, the model of the tram was the same used to investigate the prEn15227 scenarios. As a result, the crash behaviour of the tram (shown in Fig. 3) was clearly unacceptable: the failure of chassis led to a reduction in the driver's survival space which is likely to cause severe injury or death to the driver. The chassis collapses in the frontal zone and the frontal vertical beam moves back and rotate upward. In order to diminish the deformation in the frontal region of the tram three structural enhancements were introduced: wider reinforcement connections, two closed section beams in driver seat support, and a new energy absorption device between the frontal bumper and the chassis.

## STRUCTURAL ENHANCEMENTS

The structural enhancements here introduced aimed at guiding the failure mechanism of the chassis in the frontal region in effort to limit both of the backward motion and the upward rotation.

In order to achieve this goal, it was necessary to change the reinforcement connections in the frontal zone and the driver's seat support beams. Furthermore, an additional energy absorber was introduced.

**Frontal reinforcements.** A new geometry for the reinforcement connections in the frontal zone was drawn in effort to redistribute the axial loads on a larger zone, limit the plastic deformations and avoid the rotation of the vertical beam (Fig. 4).

**Driver's seat support beams.** The driver's seat support beams were changed (closed section beams were used instead of previous C section ones) the enlargement of the chassis is restrained.

**Additional energy absorber.** An additional energy absorber is introduced to reduce the higher load transferred to the chassis as a consequence of the most severe crash scenario. This device is designed to work only when the impact energy exceeds the energy absorption capability of the frontal buffers impact. It consists of two parts: an Aluminium honeycomb box and two cylinders. The dimensions of the device are limited by the free space in the frontal zone of the tram. In Fig. 5 the device is shown. Noticing that, after activation, the device needs to be replaced.

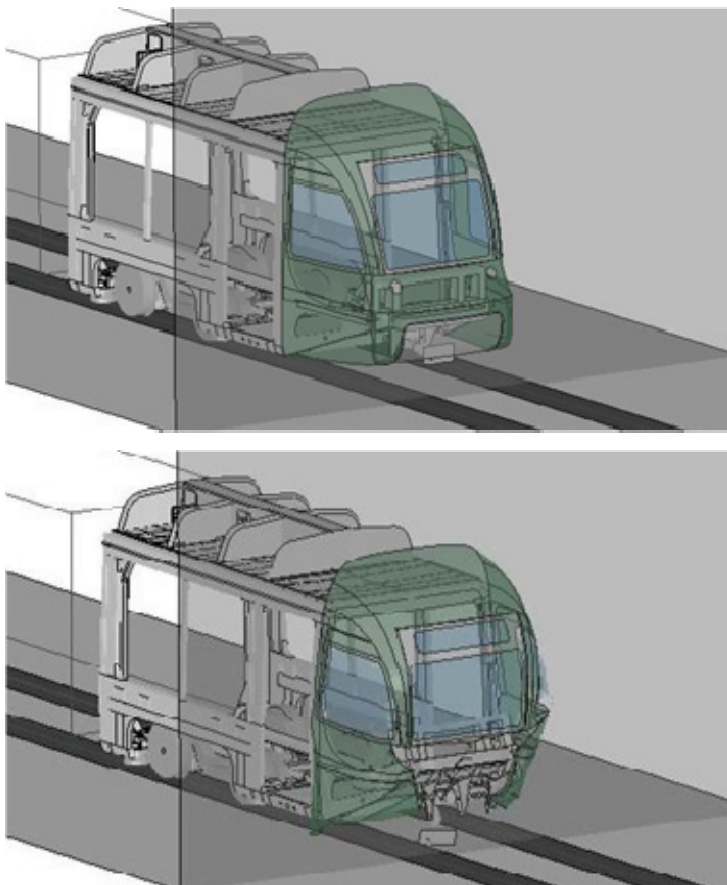

Figure 3 – Impact scenario #4 using the tram model before the structural enhancement.

The two steel cylinders absorb most of the impact energy, the Aluminium honeycomb energy absorption is about one fifth of the overall impact energy and, part of the impact energy is also absorbed by the plates that box the absorber.

The simulations of the impact scenario for the tram after the introduction of the described structural enhancements showed that the frontal chassis deformations take place only along the longitudinal direction.

In Fig. 6, a comparison between the results obtained with the initial and with the enhanced tram model is shown.

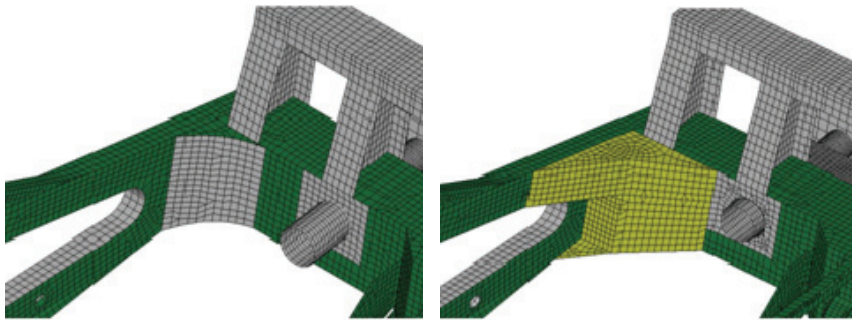

Figure 4 – Initial (LHS) and improved (RHS) geometry of the lateral beam support.

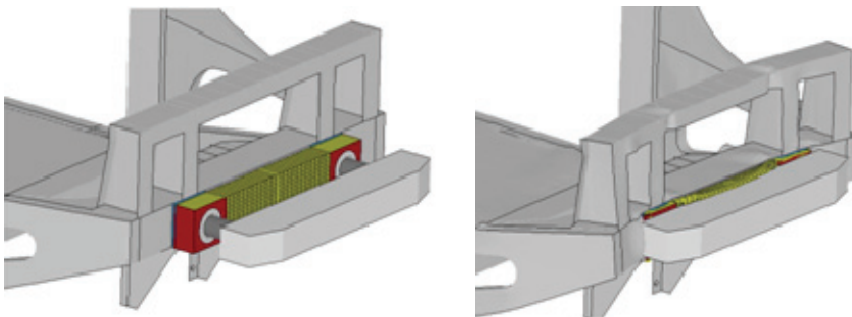

Figure 5 – The new frontal energy absorption device before (LHS) and after (RHS) the impact with the rigid wall.

The changes in the tram structure succeeded in guaranteeing the maintaining of the survival space for the tram driver.

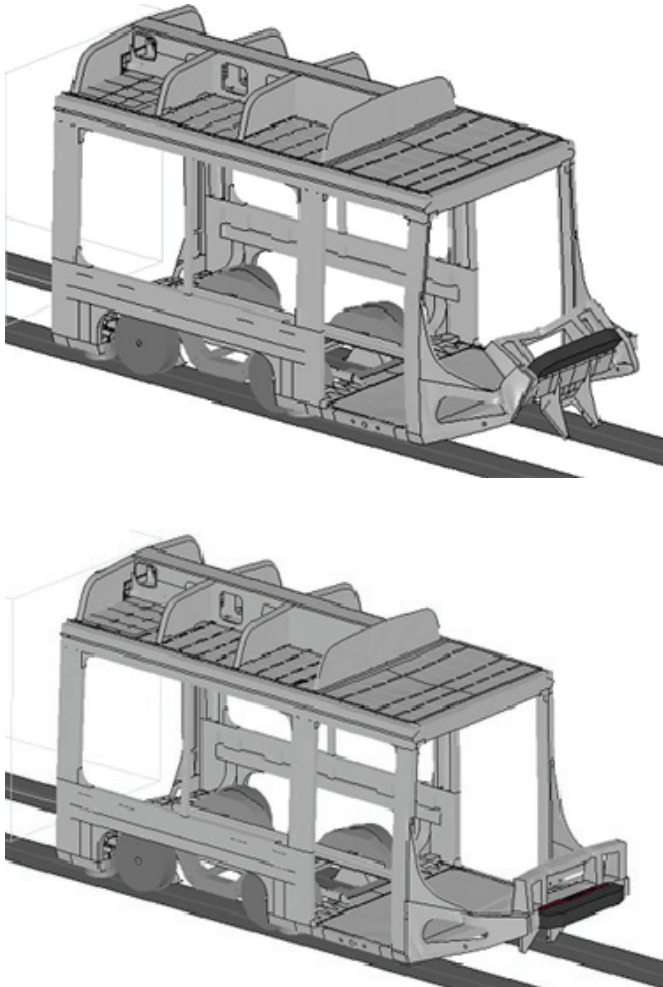

Figure 6 – Numerical simulation of new impact scenario with new model.



## **PASSENGERS' CRASHWORTHINESS**

For the passengers, prEn15227 requirements prescribe that the mean acceleration must be less than 5 g for the all duration of the impact.

The mean acceleration profiles obtained in the simulations of the four impact scenarios considered showed that scenario #4 is actually the most severe in term of mean acceleration. Nevertheless, after tram structure enhancement, also in this scenario the mean acceleration is well below the limit prescribed in prEN15227.

## **CONCLUSIONS**

In recent years, crashworthiness of urban railway vehicles has become an important and demanding issue in urban tram design.

In this work, the crash behaviour of a P-V tram, the AnsaldoBreda Sirio-Milano was investigated with regard to the three impact scenarios described in prEN 15227. Furthermore, a new scenario, called scenario #4, with most severe impact conditions is introduced.

The simulations carried out showed that the examined tram fulfils the requirements for three prEN 15227 scenarios and not the one for the new scenario. In effort to fulfil the requirements for this scenario, three structural enhancements were introduced, such to guarantee a sensible reduction of frontal chassis deformations and therefore allow satisfying the requirement on driver's safety.

The proposed structural changes, in particular, can be applied to the original structure without requiring major structural changes and therefore are readily applicable to all trams, even to the ones already delivered.

Concluding, it is worth noticing that also thanks to the contribution of this research, scenario #4 is going to be implemented in the new release of the prEN 15227.

## **REFERENCES**

1. ISTAT-ACI, "Statistica degli incidenti stradali Anno 2002" (In Italian)
2. ISTAT-ACI, "Statistica degli incidenti stradali Anno 2003" (In Italian)
3. ISTAT-ACI, "Statistica degli incidenti stradali Anno 2004" (In Italian)

4. European Technical Committee, CEN/TC 256, "EURO NORM: draft prEN 15227", April 2005
5. X Xue, F Schimd, "Crashworthiness of Conventionally Designed Railway Coaching. Stock and Structural Modifications for Enhanced Performance", 5th European LSDYNA Users Conference, Birmingham, UK, 2005
6. X Xue, F Schimd, "Modelling Study to Validate Finite Element Simulation of Railway Vehicle Behaviour in Collisions", 5th European LSDYNA Users Conference, Birmingham, UK, 2005
7. C-H Wu, C-Y Tung, J-H Lee, C C Tsai, "Improvement Design of Vehicle's Front Rails for Dynamic Impact", 5th European LSDYNA Users Conference, Birmingham, UK, 2005
8. J Hallquist, "LS-DYNA Theoretical Manual", Livermore Software Technology Corporation, 2006
9. M Pirola, F Pistochini, "Protezione dei passeggeri, del conducente e del pedone per un veicolo urbano su rotaia", Master degree thesis (in Italian), Politecnico di Milano, Department of Aerospace Engineering, October 2006
10. M Anghileri, L-M L Castelletti, F Pistocchini, M Pirola, "Urban tram design enhancements to assess pedestrian safety in a tram vs pedestrian accident" *In preparation*