

Simulation of a Vehicle Running on to a Curb by Using Tire and Vehicle FE Models

Authors:

Tatsuya Fukushima, Hitoshi Shimonishi*, Kimihiro Hayashi**, Masaki Shiraishi***

* NISSAN MOTOR CO.,LTD

1,Natsushima-cho,Yokosuka-shi, Kanagawa 237-8523, Japan

**The Japan Research Institute, Limited

2-18-25, Marunouchi, Naka-ku, Nagoya 460-0002, Japan

***SUMITOMO RUBBER INDUSTRIES, LTD

1-1, 2-chome, Tsutsui-cho, Chuo-ku, Kobe 651-0072, Japan

Keywords:

Tire, Vehicle, Curb, Simulation, LS-DYNA

ABSTRACT

A simplified FE tire model has capability to solve a large deformation of a tire on a vehicle running simulation with acceptable computational time. We tried to simulate a vehicle running on to a curb, one of vehicle strength tests, by using simplified FE tire models and a vehicle FE model which has detailed suspension models. It is necessary to solve the force to a wheel with good agreement with a car test, in order to estimate the force to suspension systems or a body as a vehicle strength problem. We confirmed that the simulated force to a wheel agreed with the force by car test.

INTRODUCTION

Currently CAE is applied to each phase of vehicle development. And there is much demand for letting a vehicle model run, for example durability, handling or ride comfort.

Currently CAE is used in most areas of vehicle design. Accurate predictions of vehicle performance from computer simulations can reduce the use of prototype vehicles and the risk of late design changes. One area in which CAE is valuable is durability, handling and ride comfort.

When we analyze the vehicle FE model running, it is important to model the correct loading through the tires from the ground. For this reason, the tire model must be accurate. However, tires are made with complex materials, such as rubber, fabric, steel mesh and so on. If we attempt to model this explicitly, the FE model may include more than 100 thousand elements. To use 4 tire models like this in a vehicle model is beyond reality. So we have developed simplified FE tire models[1][2]. Improvements on this tire model have been continued and large deformation of tires has been predicted exactly. We attached this tire model on a vehicle model, which has good capabilities for simulating suspension motion, and tried to simulate curb hitting, which is one of strength problems. We will report the comparison of axle forces between tests and analysis.

FE Tire Model

Many automobile makers produce a number of different types of cars, which have different sizes of tire. Also, it is popular to use different size tires for the one type of car. Scaling some base tire made to fit each car is one idea and this method is used widely. To scale the tire model may reduce the precision of the model. The tire structure and materials used in it depend on its size and aspect ratio. The request for different size of tires made us decide to build the tire library.

In order to keep the precision, the properties required for each size of tire were measured individually as well as FE tire models. Also the correlations were done for each tire models. We started by making an original tire model as used by a tire maker. The original models are made by following our sequence to make a very complex model based on CAD data and our material database. After making the original models, we simplified the models to be suitable for durability simulations (figure 1).

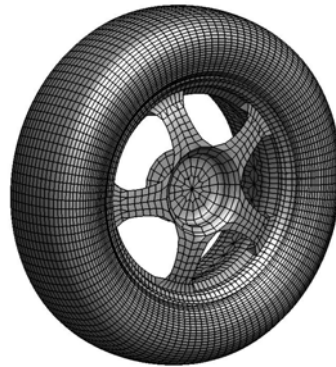

Figure 1 Simplified FE tire model

We have been trying to simulate some scenarios with our simplified tire model. For example, we know that the robustness of the tire model during a calculation can be as important as its precision. We had to improve the models for this reason. By adding solid elements and modifying the material models, we made the tire models suitable not only for durability simulation but also crash simulations. Currently there are many kinds of specifications for a tire requested from automobile makers. Tire makers will have to perform tests to check their tires. It is natural for a tire model to be requested with the same specifications as the real tire. If we have 10 test results, we need to correlate the FE tire models to 10 test results. This will result in produce of complex original model. We selected three types of tests as shown in figure 2. Those 3 tests were based on following specifications;

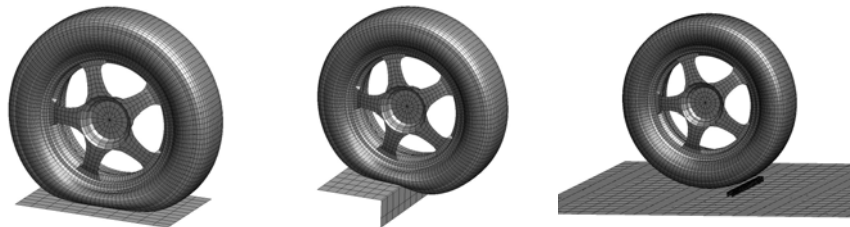

Figure 2 Correlation Tests

Pushing statically with a plane plate (vertical stiffness test) :

This is one of fundamental tests for tire models. After getting good correlation, lateral stiffness is usually inspected as well.

Pushing statically by step plate:

This test is to check the property of tire passing a step or hitting a curb.

Passing cleat test (drum test) :

This type of test was selected for correlating dynamic properties. The rotating drum test is popular amongst tire and automobile makers. The cleat size, which has a 20mm square section, is slightly larger than ones used by tire makers.

The tire model creation starts with making a complex original tire. Simple tire models were generated from these original tire models. We used the same method as we reported at DYNA conference held in 2000[3].

The tire model library will include more than 20 sizes of tires. We picked up one size and checked it with many tests to confirm the correlation and robustness. The tire structure is shown in figure 3 (Figure 4 is previous model we reported). The tire models showed good results for the 3 tests explained above, but there was a robustness problem which arose around the side wall and bead. The side wall of the tire was modeled using shell elements, which have a stiffness corresponding to the original tire. We checked the tire model robustness by impacting to an offset barrier model used in crash simulations. Of course this test is for the model's suitability for ODB (offset deformable barrier) crash simulations. When the side wall is compressed and self-contact is activated, the shell elements deformed abnormally and the calculation dropped. Various contact definitions, material models, side wall/rim shape were tested one after another.

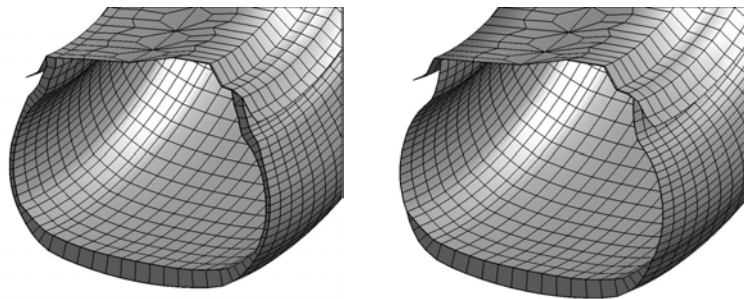

Figure 3 Section of Tire Model **Figure 4** Previous FE Tire Model

We found it was necessary to prevent the side wall shell elements from deforming abnormally. The shell elements don't have a high bending stiffness and are easily folded. Solid elements were added to the outside of the side wall shell elements using the same nodes. Mooney-Livlin rubber is used as the material model because the stress increases exponentially under high compression.

Now the side wall was modeled using not only shell elements originated in carcass and bead, but also solid elements representing the side wall rubber. The additional solid elements improved the non-linear characteristic of the vertical stiffness especially for the lower aspect ratio tires. The rim and side wall sometimes contact and vertical stiffness is slightly changed. To simulate this, the exact side wall shape is needed and the additional solid elements work well.

Tread, which does not have a tread pattern, also was modeled by solid elements. We did not take account into the influence of the tread pattern because the pattern depends on the tire brand name, and we were not concerned with the small differences in deflection the tread pattern causes. Before ignoring the tread pattern, we compare the tire model with simple tread pattern to a tire with no tread pattern. Additionally, solid elements for the tread rubber with different stiffnesses were compared. We could not find a considerable difference in the tire model. If we are concerned with very small deflections of around a few mm, tread pattern will be very important. At the moment our target for our tire library is model validity for larger deflections.

Regarding the wheel model, an elastic-plastic material, of which stiffness is similar to aluminum, is used rather than a rigid material. We found that the rigid wheel causes a very spiky spindle load. So we changed the material.

Figure 5, 6, 7 show one of the results picked up from the tire library. The crash model tire is loaded statically using a plate and a step. The durability model tire was loaded

dynamically with the rotating drum and cleat. Good correlation is shown for both tests.

The robustness of our tire models has been checked by hitting the plate and deformable barrier, which is used for offset frontal crash. Figure 8 shows the results. The idea for using the offset barrier as a robustness test came after we tried to use the model in an ODB analysis. Our tire models now have the ability to pass those severe conditions [4].

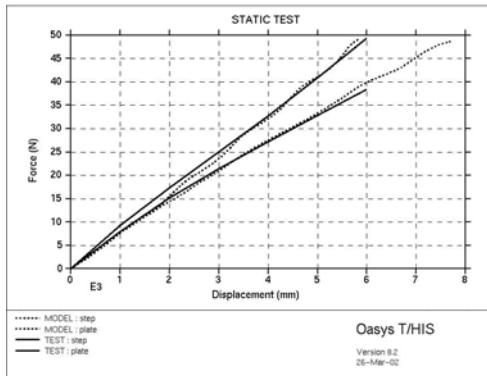

Figure 5 Static Test Result

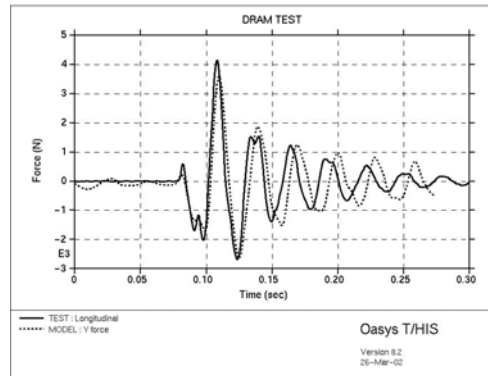

Figure 6 Dynamic Test Result

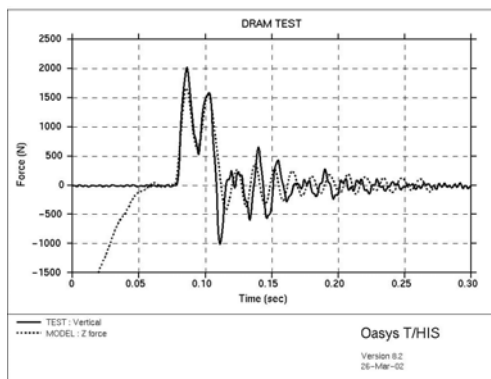

Figure 7 Dynamic Test Result

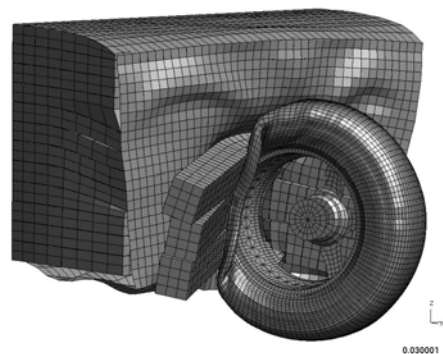

Figure 8 Robustness Test

A Vehicle Running on to a Curb

We analyzed front axle loading when a vehicle is running on to a 100mm height curb using the simplified tire models we explained above (figure 9). This curb is based on ones for pavements. The section is shown in figure 10. A vehicle shown in figure 11 will run on to this curb with angles at 20km/h. The test condition includes 2 angles of 90 and 30 degrees. For 90 degree, both right and left side tires will run on to the curb. On the other hand only left tire will run on to it for 30 degree.

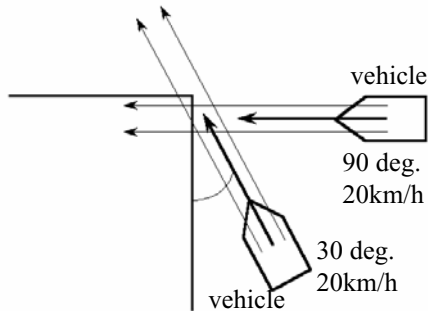

Figure 9 a vehicle running on to a curb

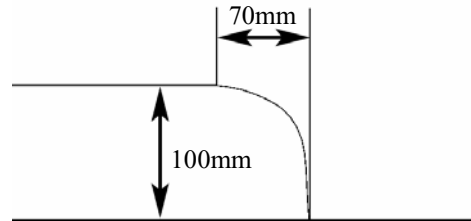

Figure 10 curb section



Figure 11 Test Vehicle

Making the Vehicle Model

We developed the vehicle model taking account into equilibrium between the inertia force of body parts above suspension and the reaction force from tires and suspension system.

- We think tires and suspension will deform mainly and made the vehicle model detail as we can analyze the deformation.
- The suspension deform means the deformation of the parts having lower stiffness than metal suspension linkage parts, including suspension spring, shock absorber, bound stopper which is coaxial on the shock absorber and suspension bushes connecting these parts. Compared to running on a flat road, larger force will be loaded on the suspension when running on to the curb, suspension parts modeled using elastic material model.
- The body parts above suspension, stiffer than the parts mentioned above b., were modeled using rigid material because a number of elements will be needed to make a FE model. The rigid body has exact mass, center of gravity and inertia.
- When the vehicle run on to the curb of 100mm height the front suspension will be compressed largely. So the compression stroke of suspension spring is limited using a bound stopper, which stop plastic deformation on shock absorber and its connecting point to the body panels.

- e. The rear suspension was modeled in detail as well as front suspension in order to simulate the supporting load of front suspension exactly.

Figure 12 shows the vehicle model and figure 13 road model including the curb. It is necessary to simulate 1 second for running on to the curb. If we use whole deformable body model like crash simulation, much longer cpu time will be needed. So we made the body as rigid body according to section c. above and the number of elements were reduced.

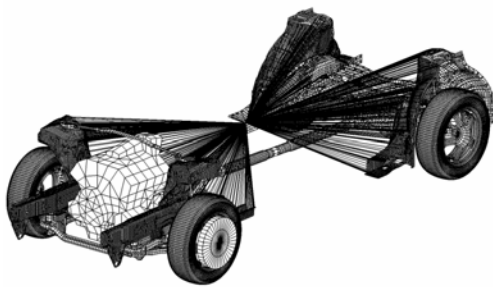

Figure 12 vehicle FE model

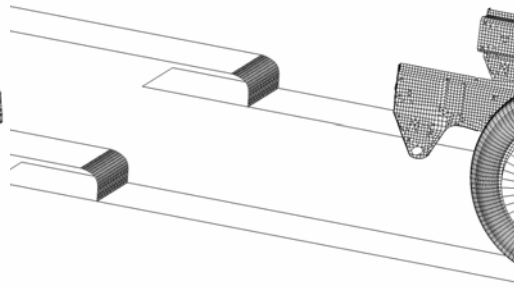

Figure 13 road model with a curb

Figure 14 shows the close up to suspension model. The simplified tire models explained above were equipped. The suspension linkage parts are modeled using shell elements.

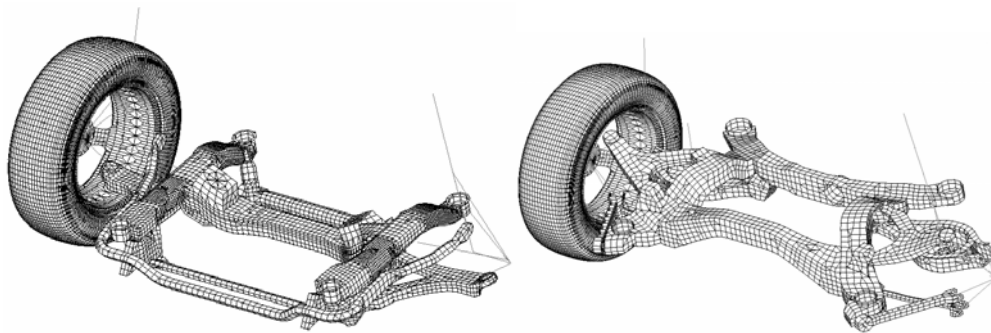

Figure 14 suspension model

The suspension and bound stopper are modeled using discrete spring elements and shock absorber discrete damper elements. The properties for suspension parts modeled discrete elements are displacement – force relation or distortion velocity – force relation, which is designed or measured.

The discrete beam elements are used for bush with 3 translational components and 3 rotation components because displacement – force relations depend on each direction. When the vehicle is running on to the curb, the bushes are loaded large forces and squashed up. At that time the bush stiffness will become very high. So we have taken account into this non-linearity on the discrete beams.

The tires will deform in lateral direction for 30 degree hitting because of lateral forces on the body. Even if the driver, driving the test car, keeps the steering wheel not rotated, steering rack / insulator, connecting steering rack to suspension member, will

deform and steering angle will be changed. To take account into this deformation, steering rack and tie-rod are modeled and steering rack / insulator are modeled using discrete beam elements. Boundary condition giving steering lateral displacement was used to simulate the force done by the driver. The road was modeled using shell elements with all nodes fixing.

Analysis conditions

At $t=0.0$ the vehicle model is stationary with the tires off the road. Starting with this states, the gravity (acceleration = 9.8m/sec^2) is loaded for whole model. After gravity loading, the vehicle is accelerated by displacement boundary condition on its center of gravity. And then the vehicle will reach the target velocity just before hitting the curb. At first we planed to use 5.6m/sec (20km/h) and instructed the driver to operate the car at this velocity. In reality the velocity was 5.2m/sec for 90 degree case. So we also use 5.2m/sec for simulation.

The tires have the free rotation degree and will rotate at adequate velocity by friction force between tires and road during vehicle accelerated motion.

Comparison between test and simulation

The data of a vehicle running on to a curb showed in figure 12 and 13 was analyzed using COMPAQ ES40 (CPU: $\alpha 833\text{MHz}$) 4 CPUs with SMP LS-DYNA960. The analysis time is 1 second and it is 0.5 second before the vehicle hitting the curb. 10 days were needed to complete this analysis. Figure 15 shows the behavior of the vehicle and figure 16 shows the tire deformations when passing the curb. We can see the deformation difference between 90 and 30 degree approach.

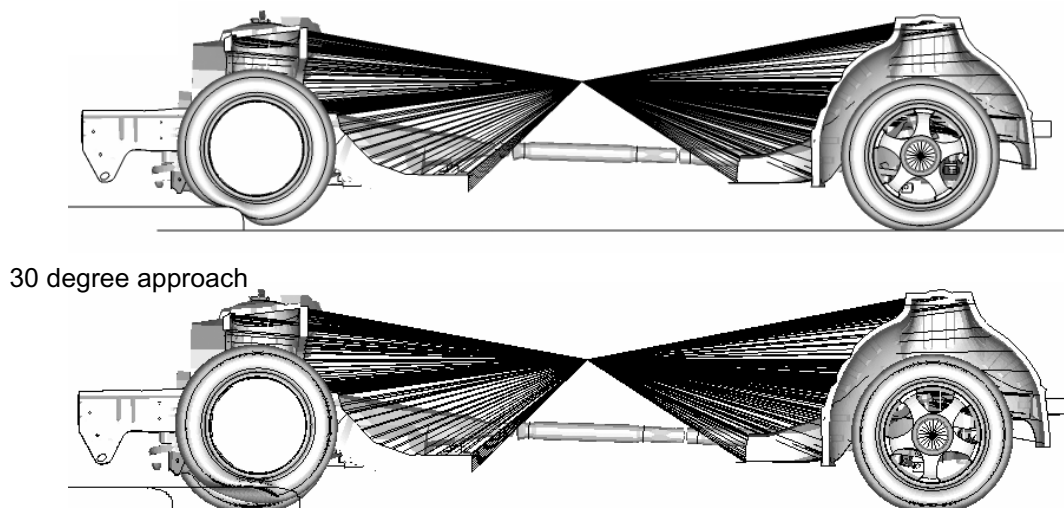

Figure 15 the behavior of vehicles when hitting the curb

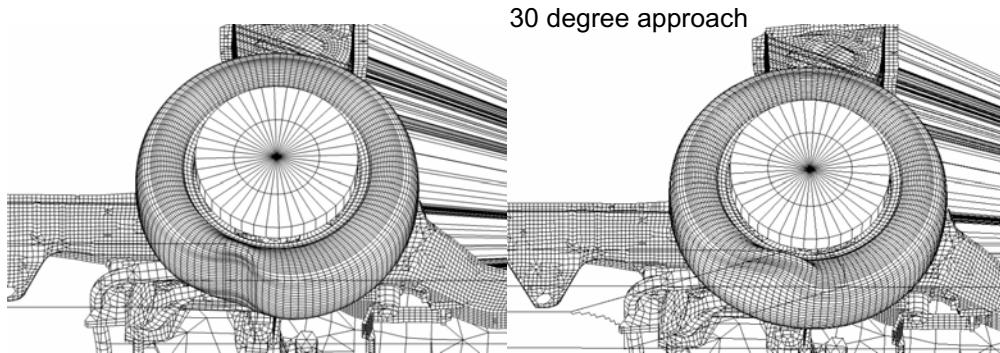

Figure 16 the deformation of tires when passing the curb

Next we compared the forces of left front tire between test and simulation during hitting the curb. In the simulation result the contact forces between the tires and road were used. The other hand the forces used in test results were measured by load meter attached on the tire axle showed in figure 17.

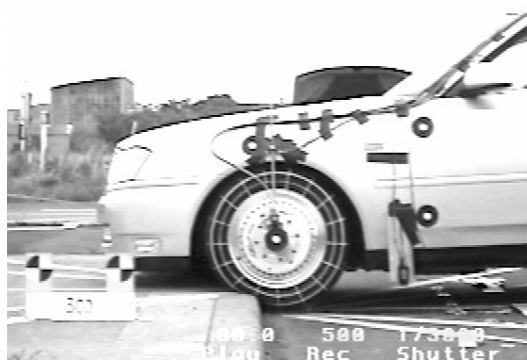

Figure 17 the measurement of forces on the wheel during hitting the curb

Figure 18 shows the forces on the front left wheel. The peak load on the wheel shows good agreement with test results. There are 3 peaks of loading for vertical component seen in both 90 degree and 30 degree tests. The simulation results have 3 peaks like tests with a little difference of peak value and its timing. Figure 19 shows the force difference between before hitting curb and reaching maximum value for 90 degree and 30 degree approach.

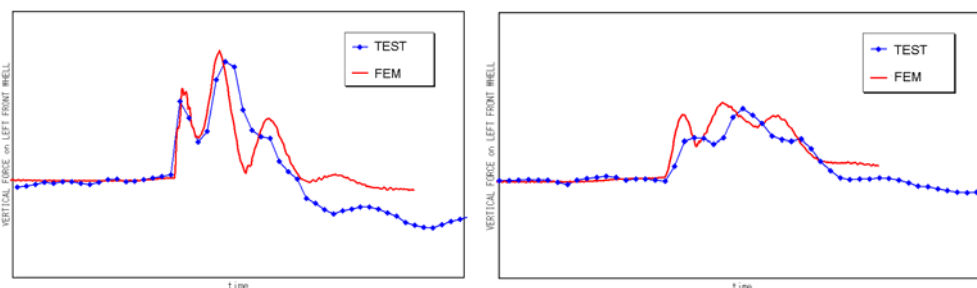

Figure 18 force comparison on left front wheel(left:90 degree, right:30 degree)

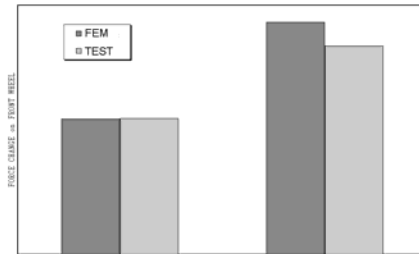

Figure 19 force change on left front wheel

We can see that the simulation shows the force increasing according to approach angle increasing.

By using simplified FE tire models and an adequate vehicle model, we were able to confirm the capability of estimating the maximum forces on tires for 90 degree and 30 degree approaches, in which the tire deformations are different.

Summary and Conclusions

We have improved simplified FE tire model making it possible to simulate a running vehicle model in order to be used for large deformation analysis, one of vehicle strength problems. Using this tire model for a vehicle running on to a curb, we confirmed that the force on front wheels agreed with test results. It is expected to reduce the number of proto-type cars to test and design suspension or bodies by simulations using this tire model.

References

1. IWASAKI, SHIRAISHI, YOSHINAGA, HAYASHI, DOI (1999) "FEM Tire Model for Durability Simulations", LS-DYNA User Conference, pp. 23-1 - 9.
2. HAYASHI (1999) "Simulation of Vehicle Passing a Curb Using FEM Tire Model", LS-DYNA User Conference, pp. 24-1 - 10.
3. SHIRAISHI M., YOSHINAGA H., IWASAKI N., HAYASHI K (2000) "Making FEM Tire Model And Applying It For Durability Simulation", 6th International LS-DYNA Users Conference, Detroit.
4. SHIRAISHI M., IWASAKI N., SARUWATARI T., HAYASHI K (2002) "Developing FE-Tire Model Library for Durability and Crash Simulation", 7th International LS-DYNA Users Conference, Detroit.