

WorldSID 50th vs. ES-2

A Comparison Based on Simulations

Sebastian Stahlschmidt, Alexander Gromer

DYNAmore GmbH, Stuttgart, Germany

Matthias Walz

Daimler AG, Sindelfingen, Germany

Abstract

For testing side impact performance of vehicles two recent male-sized dummies are available. Currently only the ES-2(re) is used in regulations and consumer test. It is expected that the WorldSID will be used for some load cases as substitute or in addition to the ES-2(re). Since only limited experience with the WorldSID is available, simulation is a ideal tool to face the upcoming challenge.

The comparison employs detailed finite element dummy models of the ES-2(re) and WorldSID which have been developed in cooperation with the German Association for Automotive Research (FAT) and the Partnership for Dummy Technology and Biomechanics (PDB) during the last years.

The paper compares the behavior of the dummy in selected body regions. It showcases in different load cases if the experiences gained with the ES-2(re) can be used to design a vehicle for tests with the WorldSID.

Introduction

For assessing the side impact performance of a vehicle for a mid size male person the ES-2 and a slightly modified dummy, the ES-2re are used in tests. The ES-2 dummy is based on the EuroSID-1 which was developed in 1980s. It was designed to address the important shortcomings of the EUROSID-1 while biofidelity was maintained or enhanced. Since 1997 an ISO task group has developed a new side impact dummy with a significant different design. With the new design it was possible to increase biofidelity in all body regions. Table 1 depicts a comparison of the 2 dummies in the ISO biofidelity ranking scale. The usage of the WorldSID to assess vehicle safety is discussed frequently and it is likely that an assessment test with this dummy will be announced in the near future.

	Head	Neck	Shoulder	Thorax	Abdomen	Pelvis	Overall
ES2	5.0	4.4	5.3	5.2	2.6	5.3	4.6
World-SID production version	10.0	5.6	7.1	8.3	7.8	6.1	7.6

Table 1: ISO biofidelity ranking scale of ES2 and World-SID [1]. Higher the value, better is the correlation of the dummy with a human; 10 is the best achievable mark.

This paper presents a comparison of the ES-2 and WorldSID dummies based on numerical simulations with LS-DYNA[®] models. Both models have been developed by the authors in cooperation with task groups of the German automotive industry. Members of the task group came from Audi, BMW, Daimler, Opel, Porsche and Volkswagen. More details in the projects are presented in [2, 3 and 4]. The model of the ES-2 and ES-2re are used by almost all OEMs

that imply LS-DYNA for crash analysis. The WorldSID model has been developed recently and is used by the task group members and a few other OEMs. Both models are commercially available. The models are validated on material and component level as well as on fully assembled level. The fully assembled dummies are tested in pendulum and various sled tests. The test matrix and the correlation with tests are presented in www.dummymodels.com. The authors have been involved in the model development of both models and work in the field of passive safety since many years. In the following the different behavior of the two dummy models in pendulum and sled tests is outlined. The paper concludes the comparison with experiences made in vehicle simulations.

Since the WorldSID has significantly more measurement devices and the measurements of the two dummies are difficult to compare, the focus of the comparison is on the global movement and the impact forces occurring in the tests.

Geometric differences

Both dummies, the ES2re and the WorldSID are 50th percentile male dummies. To compare the models, the positioned dummies are seated on the WorldSID bench. The WorldSID is not able to sit free without a backrest, because of a very soft lumbar spine.

The following figure depicts the differences in the WorldSID bench of the ES2re and the WorldSID.

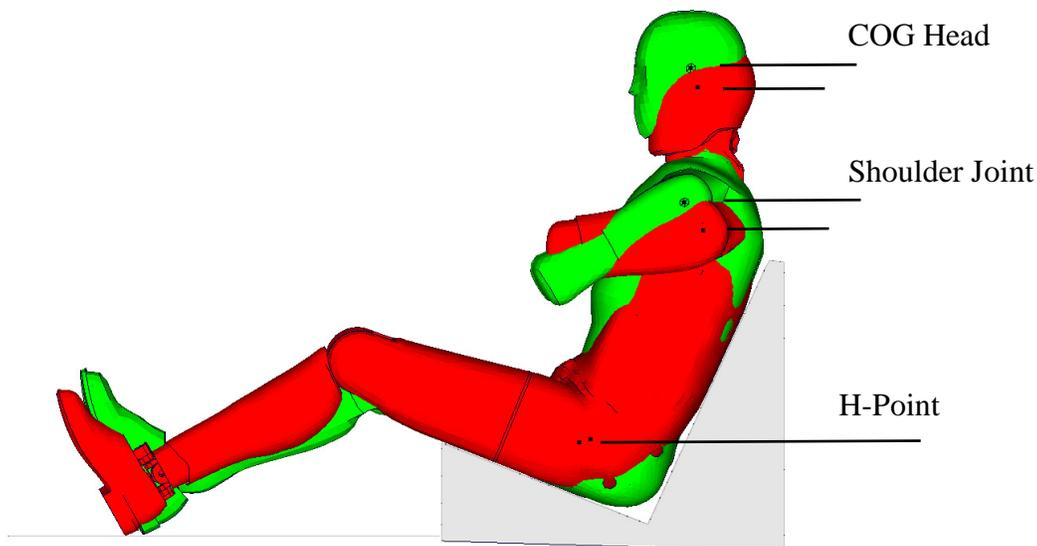

Figure 1: ES2re (green) and WorldSID (red) on WorldSID calibration bench.

The H-Point height is very close to each other. Both dummies are leaning at the back of the bench. The shoulder joints of the dummies are quite different. Here it can be clearly seen that the ES2re is about 50 mm higher and 30 mm more forward than the WorldSID. This is also observed in the COG of the Head. It is located about 80 mm higher for the ES2re than the

WorldSID. The arms are both arrested in the second notch which means 40 degree rotated with respect to the connection part.

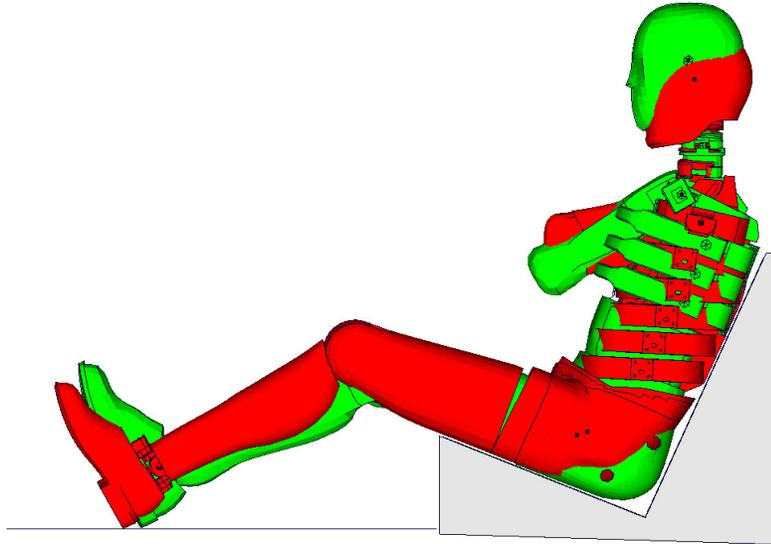

Figure 2: ES2re (green) and WorldSID (red) on WorldSID bench without arm and jacket.

Without the jacket the ribs of both models are visible. For the ES2re the ribs are oblique with the angle of the torso. This is not the same for the WorldSID, where all ribs are nearly horizontal for a similar torso angle.

In the following, the differences of the components are discussed more in detail.

Head and Neck

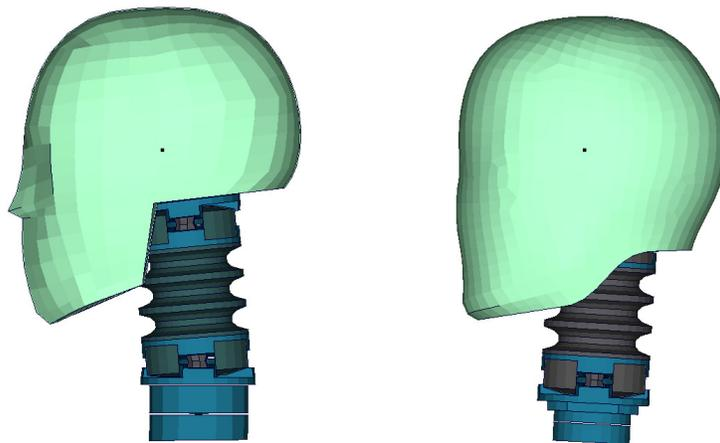

Figure 3: Head and neck model ES2re (left hand side) and WorldSID (right hand side)

The components head and neck of the ES2re and the WorldSID look very similar. The head of the WorldSID is completely different and new from the geometric point of view. Also it consists out of different materials.

The neck of both dummies has nearly the same construction and uses the same materials as well. The main difference of the WorldSID neck is the usage of different front and aft buffers in the upper and lower neck joints.

Upper Torso

The construction of the upper torso of these two dummies is very different. The ES2re provides a clavicle to which the arm is connected. Thus the arm can move forward by rotating the clavicle in the clavicle box. The WorldSID uses instead of this a shoulder rib to which the arm is connected to (closer to the sid2s construction).

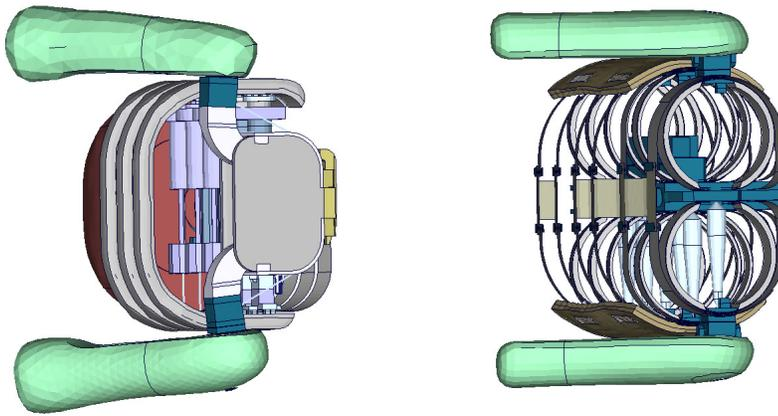

Figure 4: upper torso top view ES2re left hand side and WorldSID right hand side.

Below the clavicle/shoulder rib, both dummies consist of three thorax ribs. On the ES2re ribs a CONFOR[®] pink foam is tied on each single rib. The WorldSID ribs are covered with an ensolite foam pad which is only connected by a hook-and-loop fastener.

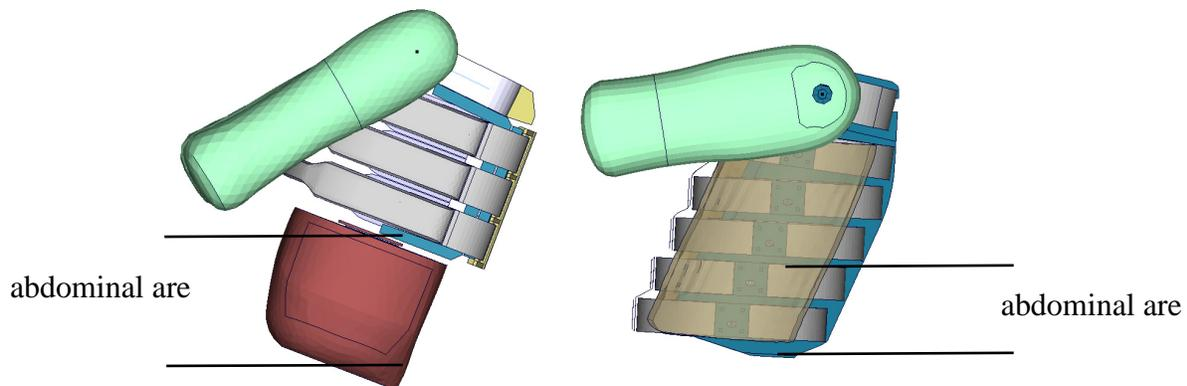

Figure 5: upper torso side view ES2re left hand side and WorldSID right hand side.

The rib construction itself is also very different. The ES2re provides a steel rib with a bearing system. Thus the rib can only move in the direction of the bearing system. The damping of the rib is done by a separate damper which is also connected to the steel rib.

For the WorldSID ribs construction Nitinol is used as rib material, which has a quite different behavior than normal steel. For system damping a damping material (also similar to the sid2s construction) is tied on the Nitinol rib. For a more detailed description of the WorldSID rib construction please see [2].

Below the thorax ribs, there is the abdominal area. This area is completely different for both dummies. The ES2re provides an abdomen foam part which is put on a stiff force measurement system. The stiffness of the abdomen area is dominated by the abdomen foam stiffness.

In contrast the WorldSID uses two additional abdomen ribs, which have the same construction and similar behavior to the thorax ribs. The stiffness of the abdomen area of the WorldSID is dominated by the rib stiffness.

The connection between upper and lower torso in both models is given by the lumbar spine. Both dummies differ in the design of this part, too.

Lumbar Spine

The lumbar spine is the linking part of the upper torso to the lower torso. It influences the global kinematic of the dummies significantly. The following figure depicts the lumbar spine in the pelvis of both models.

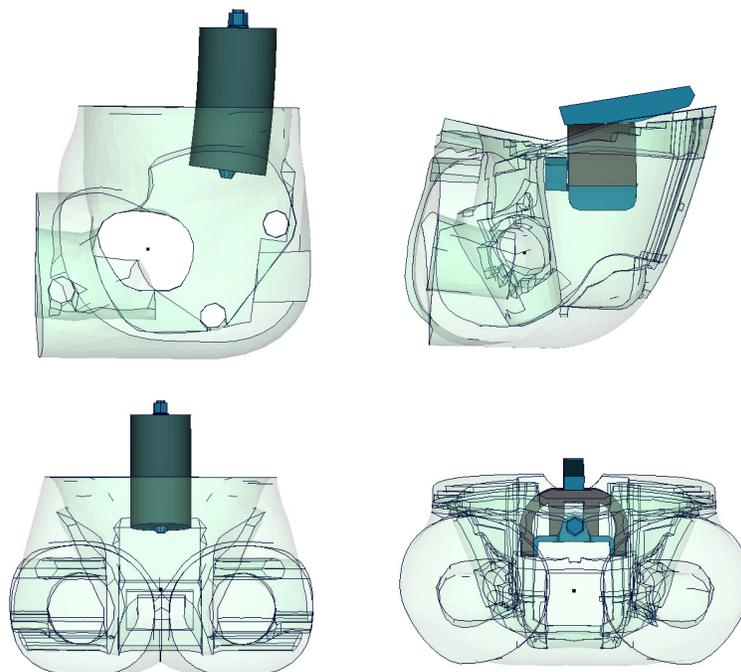

Figure 6: lumbar spine of ES2re (left hand side) and WorldSID (right hand side) in side view and front view.

The lumbar spine of the ES2re is a cylindrical rubber part. In the middle of the part a steel cable is running through the spine and is used to give a small pre-stress on the rubber part.

The lumbar spine of the WorldSID has a completely different construction. It is a rubber bow which is connected on the lower outer sides to the pelvis. In the middle of the bow it is connected to the spine. In the middle of the bow two small rubber legs are standing without a connection on a steel plate of the sacrum block. When the spine deforms the two small legs of the lumbar spine are able to move free on the steel plate.

The lumbar spine of the WorldSID compared to the ES2re is very soft. Thus the WorldSID is not able to sit autonomously without a backrest.

Pelvis Bones

The pelvis bones for both models are constructed by a very stiff sacrum block. At this block plastic iliac wings are connected. At the front both models provide a pubic symphysis load cell. The ES2re uses on both sides pelvis plugs which are in line with the hip joint axis.

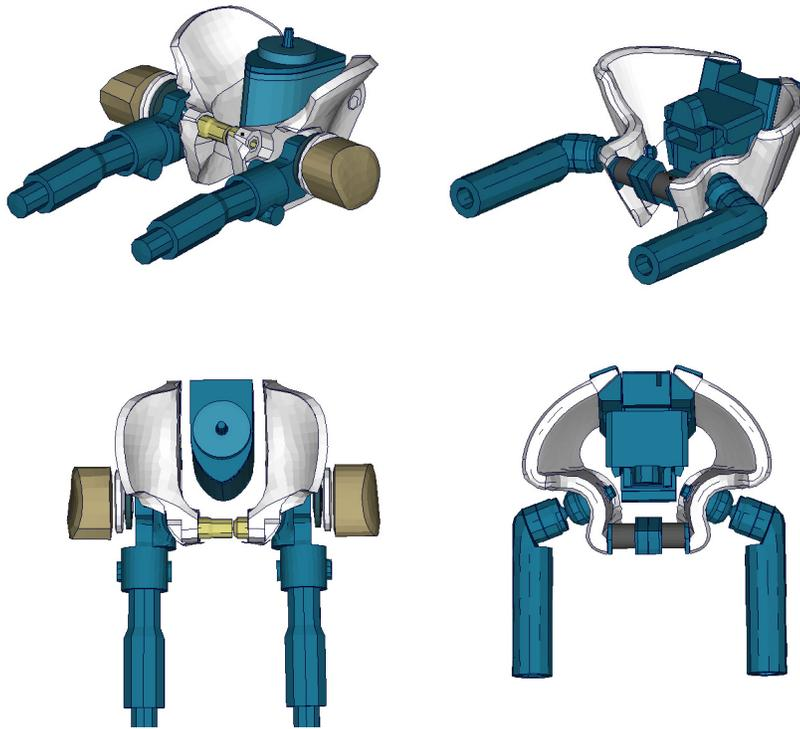

Figure 7: pelvis bone of ES2re (left hand side) and WorldSID (right hand side) in ISO view and top view.

The pubic load cell for the ES2re is directly connected to the plastic iliac wings. The WorldSID pubic load cell is tethered by two rubber bumpers to the iliac wings.

Differences under simple Pendulum Loads

To determine different load behavior we first used simple pendulum tests on the dummies. The models are positioned in the WorldSID bench as described in the previous chapter. The Dummies are used without the jacket and without the left arm.

Thorax Test

First test which was done is similar to the thorax calibration test. The normal calibration pendulum is used with two different velocities.

The pendulums are positioned in such a way that they hit the center of each middle thorax rib. In this case all thorax ribs will be impacted by the pendulum. The following picture depicts the load case for both models.

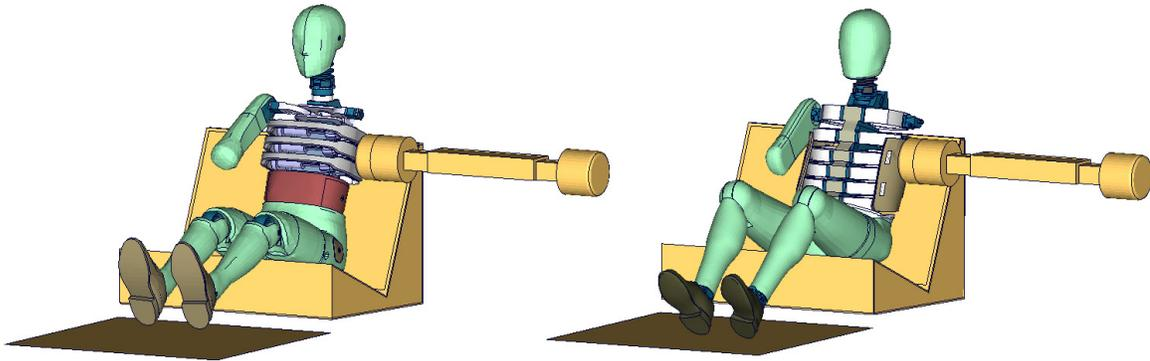

Figure 8: ES2re thorax pendulum test (left hand side) and WorldSID thorax pendulum test (right hand side)

The results of the test are depicted in the following figures.

3.0 m/s pendulum speed:

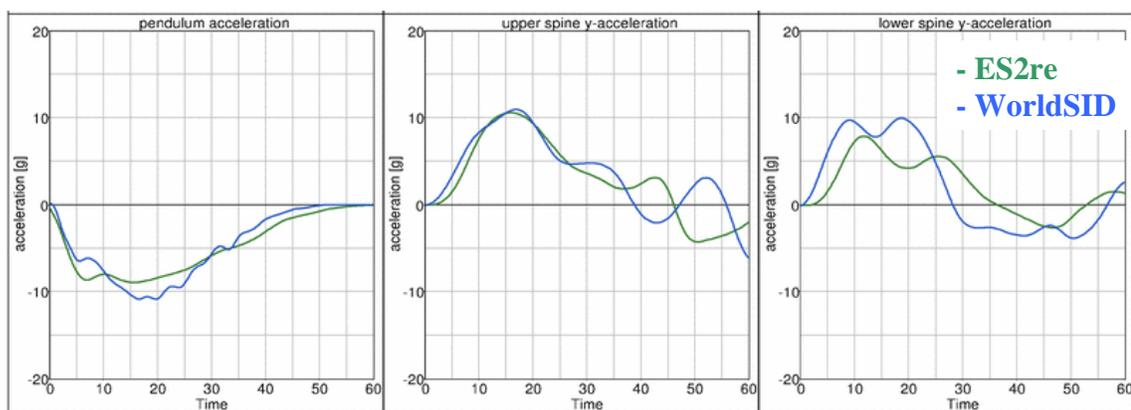

Figure 9: 3.0 m/s thorax test; pendulum, upper spine and lower spine accelerations [g] vs. time [ms].

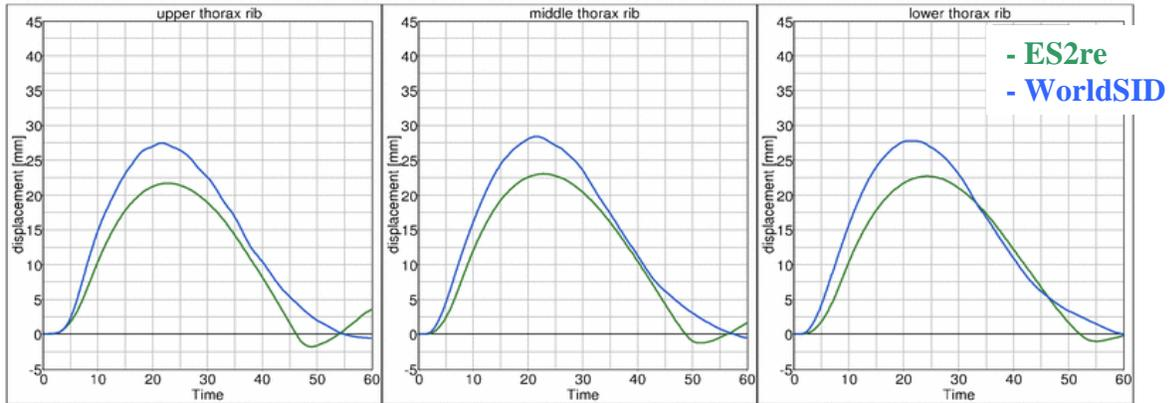

Figure 10: 3.0 m/s thorax test; upper, middle and lower thorax rib deflection [mm] vs. time [ms].

4.3 m/s pendulum speed:

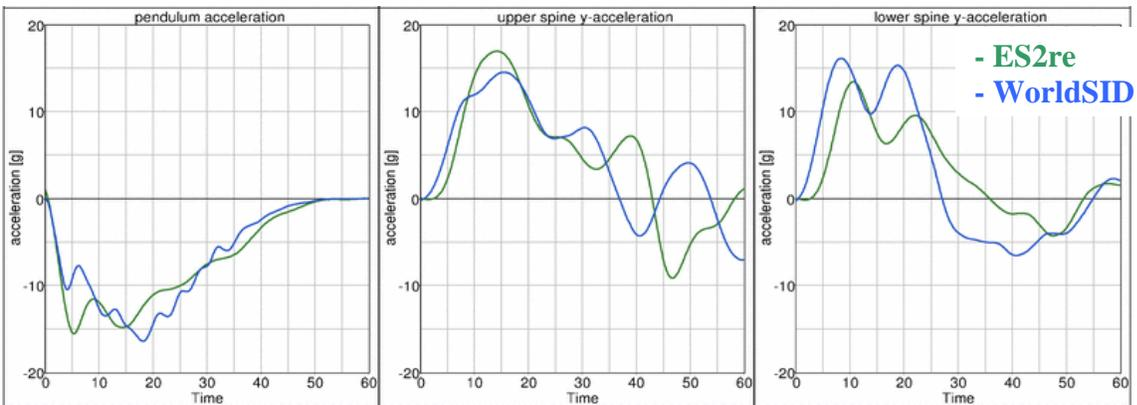

Figure 11: 4.3 m/s thorax test; pendulum, upper spine and lower spine accelerations [g] vs. time [ms].

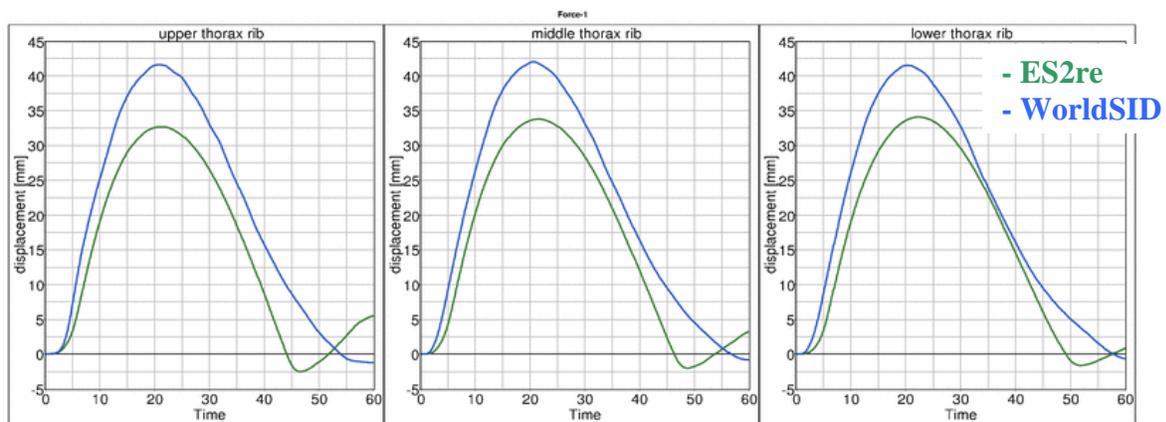

Figure 12: 4.3 m/s thorax test; upper, middle and lower thorax rib deflection [mm] vs. time [ms].

The load range is chosen as about 20 to 35 mm for the ES2re rib deflection. For both load cases the pendulum decelerations look very similar. Also the accelerations of the upper spine are not very different.

It seems that the upper torso of the WorldSID accelerates a little bit more at the lower spine area. The reason therefore should be the much softer lumbar spine of the WorldSID.

When we look at the rib deflections, we can observe that the ES2re shows about 5 to 10 mm lower rib deflections than the WorldSID with the same energy input.

Abdomen Test

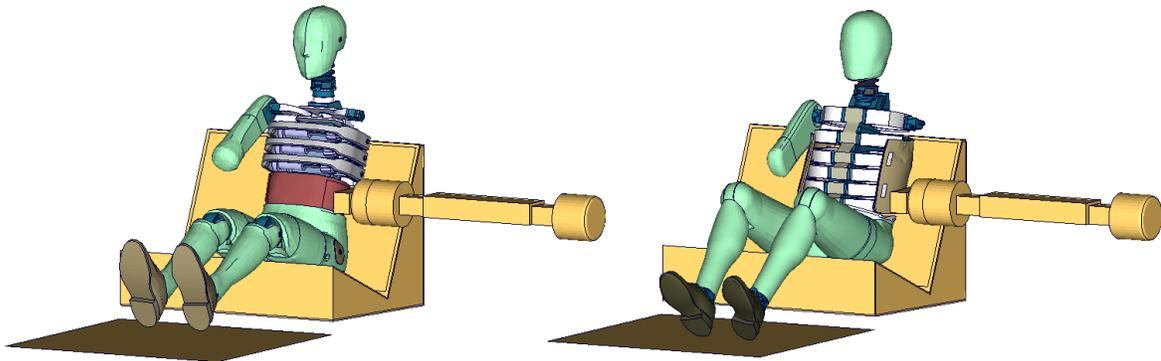

Figure 13: ES2re abdomen pendulum test (left hand side) and WorldSID abdomen pendulum test (right hand side)

For the abdomen test the pendulum is equipped with a small block at the front. This block is necessary to hit only the two abdomen ribs of the WorldSID. Also the ES2re should only be hit at the abdomen area. Again the test is done by using two speeds. The following figures show the results of the pendulum test.

3.0 m/s pendulum speed:

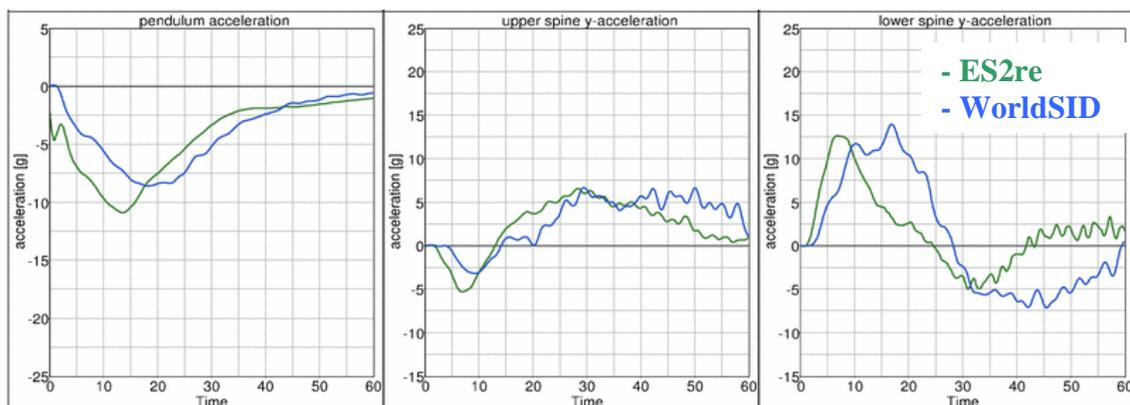

Figure 14: 3.0 m/s abdomen test; Pendulum, lower spine and upper spine acceleration [g] vs. Time [ms].

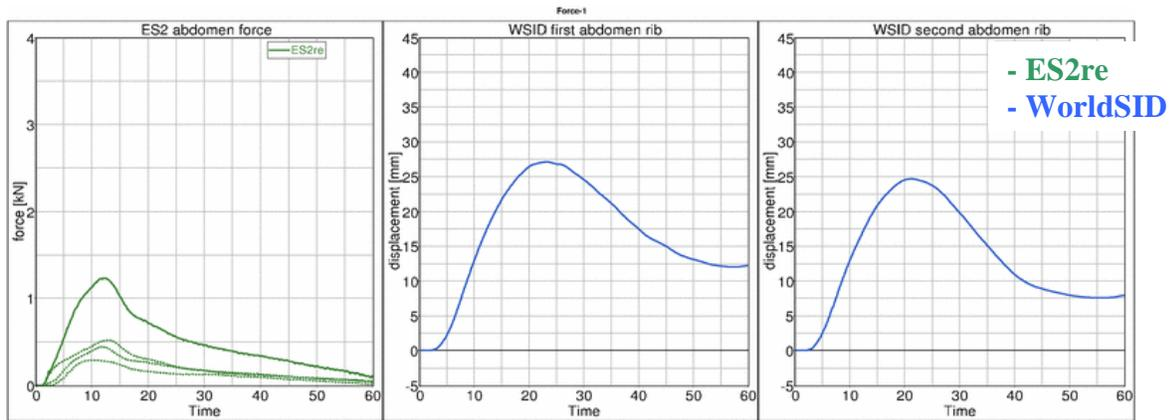

Figure 15: 3.0 m/s abdomen test; ES2re abdomen forces [kN] and WorldSID upper and lower abdomen rib deflection [mm] vs. Time [ms]

4.3 m/s pendulum speed:

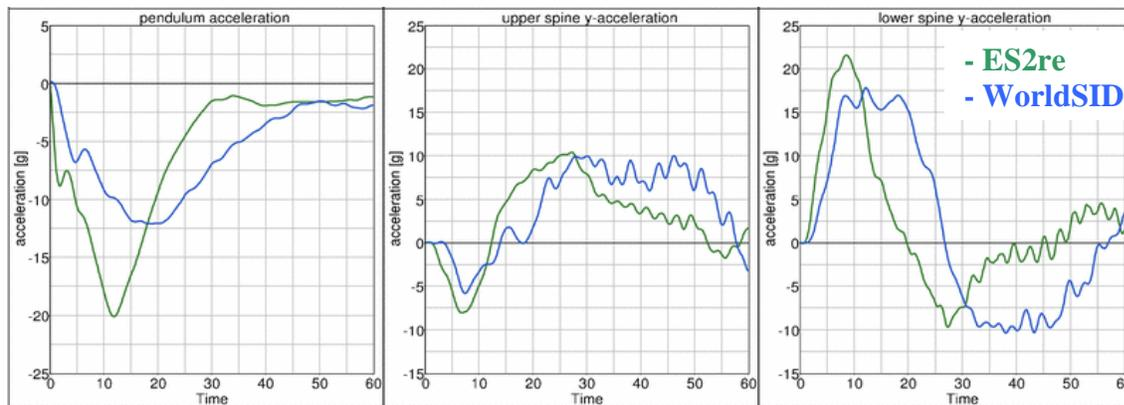

Figure 16: 4.3 m/s abdomen test; Pendulum, lower spine and upper spine acceleration [g] vs. Time [ms].

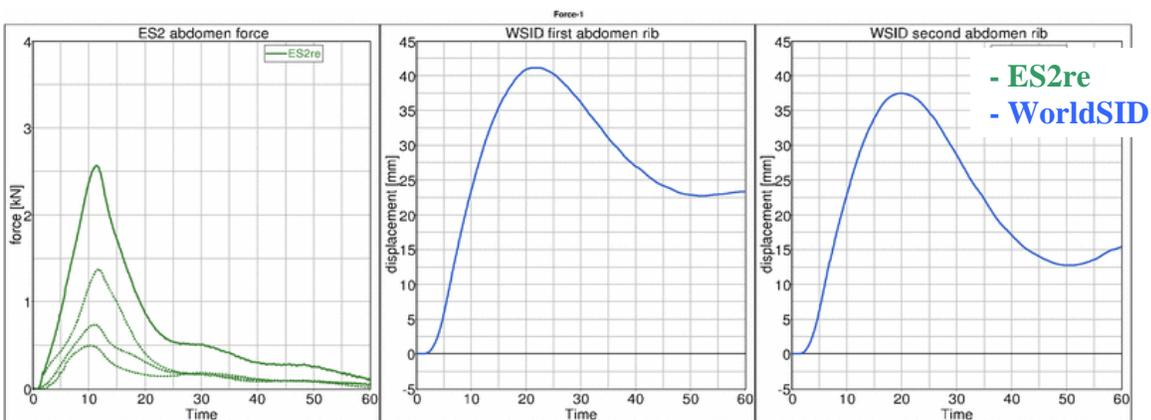

Figure 17: 4.3 m/s abdomen test; ES2re abdomen forces [kN] and WorldSID upper and lower abdomen rib deflection [mm] vs. Time [ms]

The deceleration of the pendulum on the ES2re abdomen is higher than on the WorldSID abdomen ribs. Also the first slope of the WorldSID acceleration curve is lower and it seems that the abdomen ribs of the WorldSID have a softer behavior than the abdomen foam of the ES2re.

This can also be seen in the spine accelerations. The slope of the accelerations in the ES2re is much steeper than for the WorldSID.

Pelvis Test

The pelvis test is conducted in the same way like the thorax and abdomen tests. The pendulum speeds for the pelvis impact are 4.0 m/s and 6.7 m/s. The target point is on the axis of the hip joints for both dummies. Figure 18 depicts the test setup.

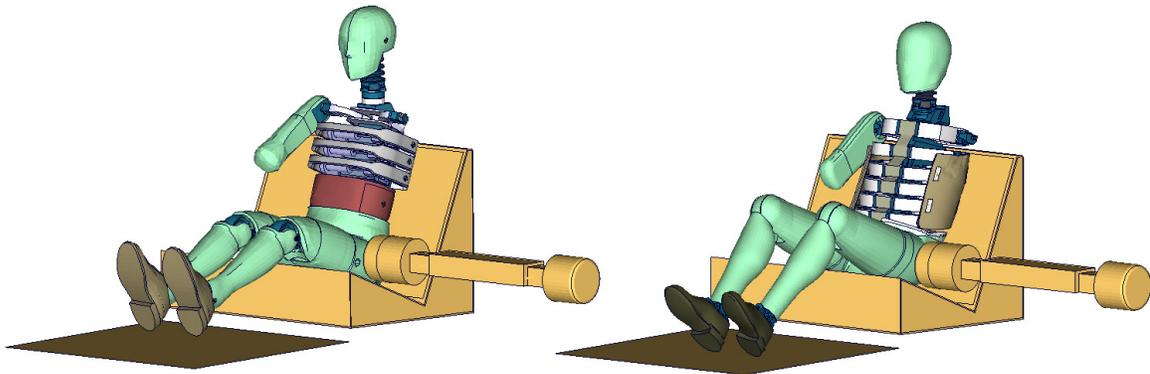

Figure 18: ES2re pelvis pendulum test (left hand side) and WorldSID pelvis pendulum test (right hand side)

The following figures show the results of the pelvis test for both speeds.

4.0 m/s pendulum speed:

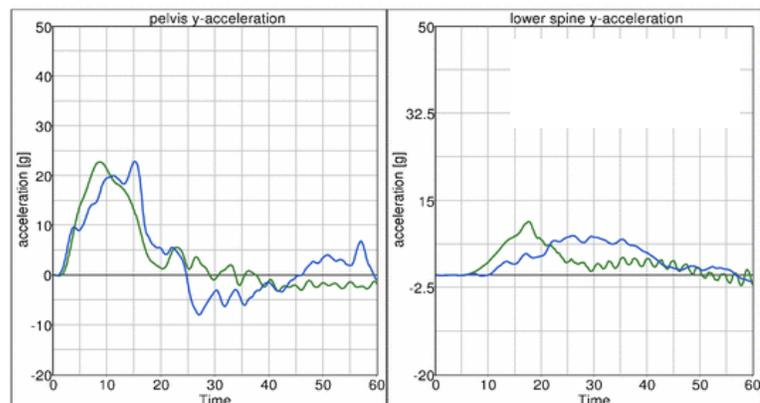

Figure 19: 4.0 m/s pelvis test; pelvis and lower spine acceleration [g] vs. Time [ms].

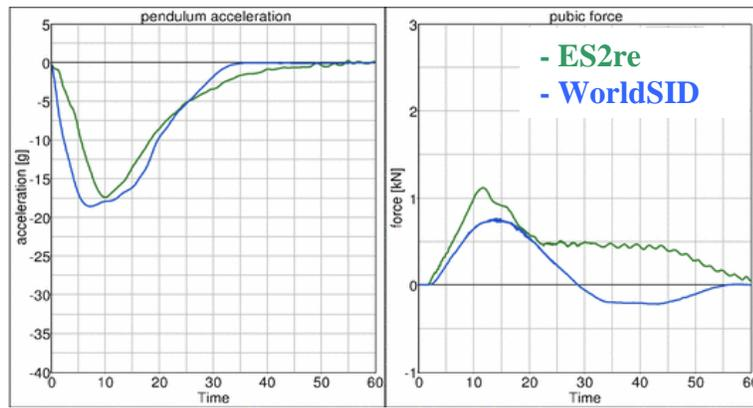

Figure 20: 4.0 m/s pelvis test; Pendulum acceleration [g] and pubic force [kN] vs. Time [ms].

6.7 m/s pendulum speed:

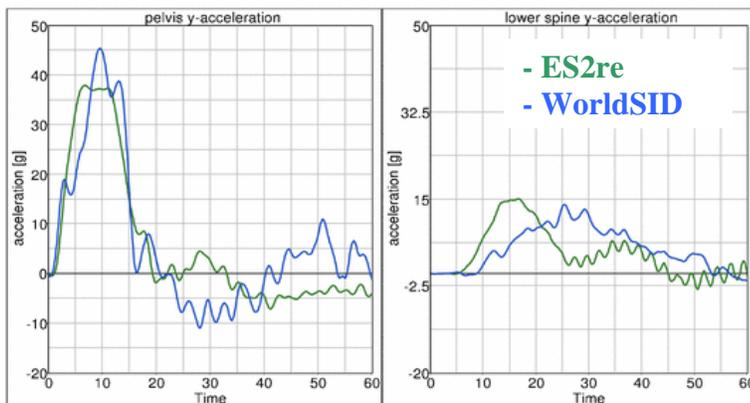

Figure 21: 6.7 m/s pelvis test; Pelvis and lower spine acceleration [g] vs. Time [ms].

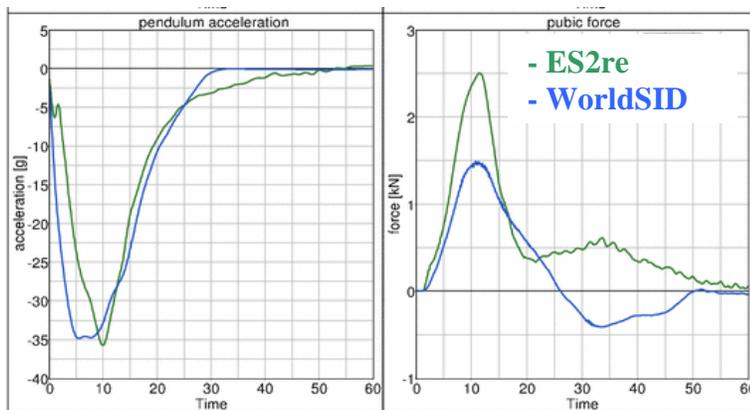

Figure 22: 6.7 m/s pelvis test; Pendulum acceleration [g] and pubic force [kN] vs. Time [ms].

In the pelvis pendulum test, the pendulum deceleration increases much quicker for the WorldSID than the ES2re. This means the Pelvis of the WorldSID is either stiffer or the weight of the WorldSID Pelvis flesh is higher.

The weights of the pelvis flesh are 3.5 kg for the ES2re and about 12.0 kg for the WorldSID. The reason therefore is a very heavy Hyperlast filling of the WorldSID pelvis and a light Foam filling of the ES2re pelvis flesh. This leads to a inert behavior of the WorldSID in this test.

Comparison of Kinematic Behavior in Sled Test

To compare a global behavior of the two dummies, a flat barrier shape is used for a sled test. Again the test is done on the WorldSID bench and the barrier has a velocity of 4 m/s. The arm position is in the second notch for both dummies, which means for both dummies 40 degree arm position. The following picture depicts the test setup.

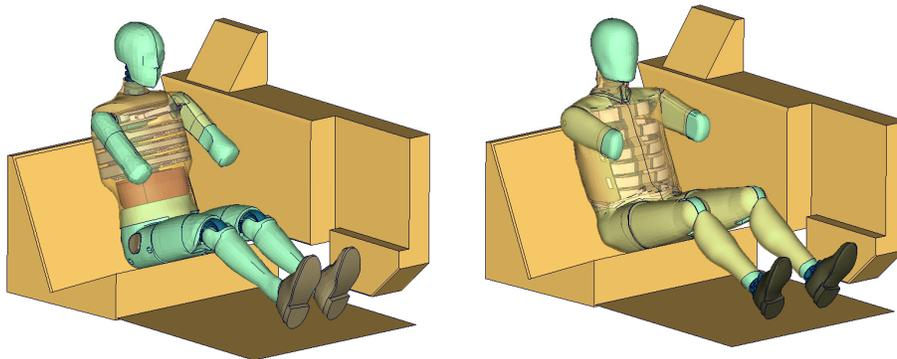

Figure 23: ES2re (left hand side) and WorldSID (right hand side) sled test with flat barrier and 4 m/s.

The next diagrams show some selected results of the sled test, where the ES2re (green lines) is compared to the WorldSID (red lines).

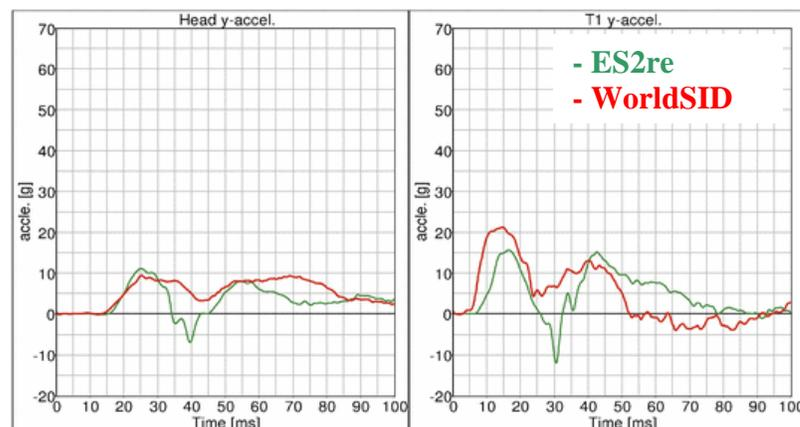

Figure 24: flat barrier 4 m/s; Head and T1 y-acceleration [g] vs. Time [ms].

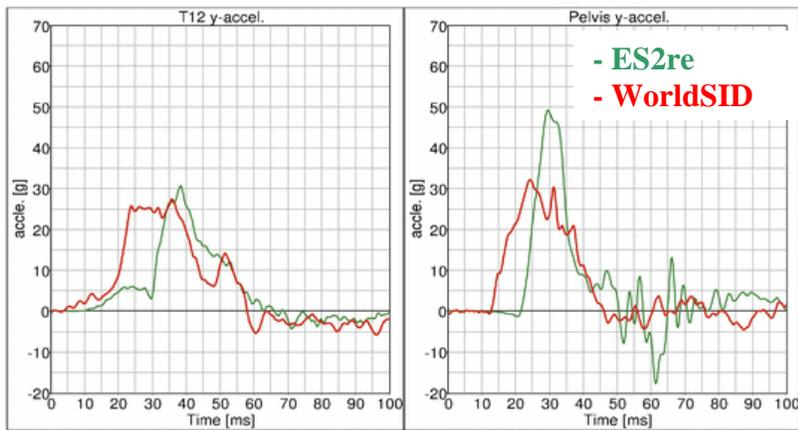

Figure 25: flat barrier 4 m/s; T12 and pelvis y-acceleration [g] vs. Time [ms].

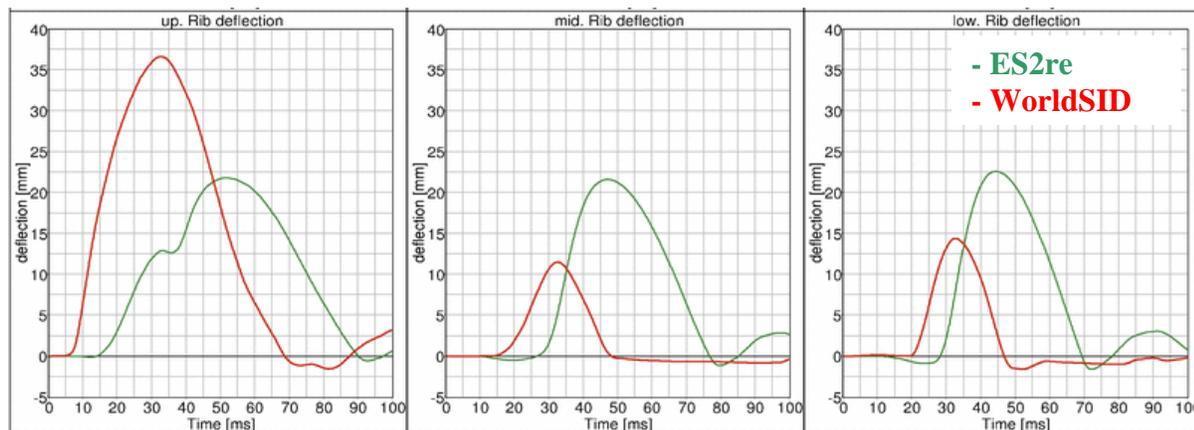

Figure 26: flat barrier 4 m/s; Upper, middle and lower thorax rib deflections [mm] vs. Time [ms].

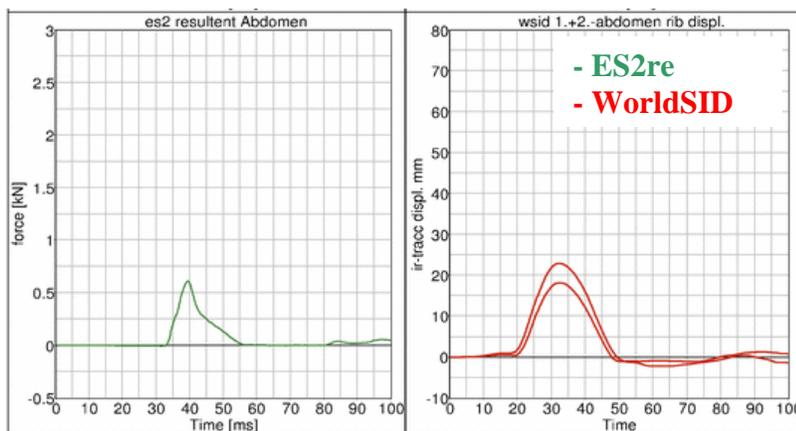

Figure 27: flat barrier 4 m/s; ES2re resultant abdomen force [kN] and WorldSID abdomen rib deflections [mm] vs. Time [ms].

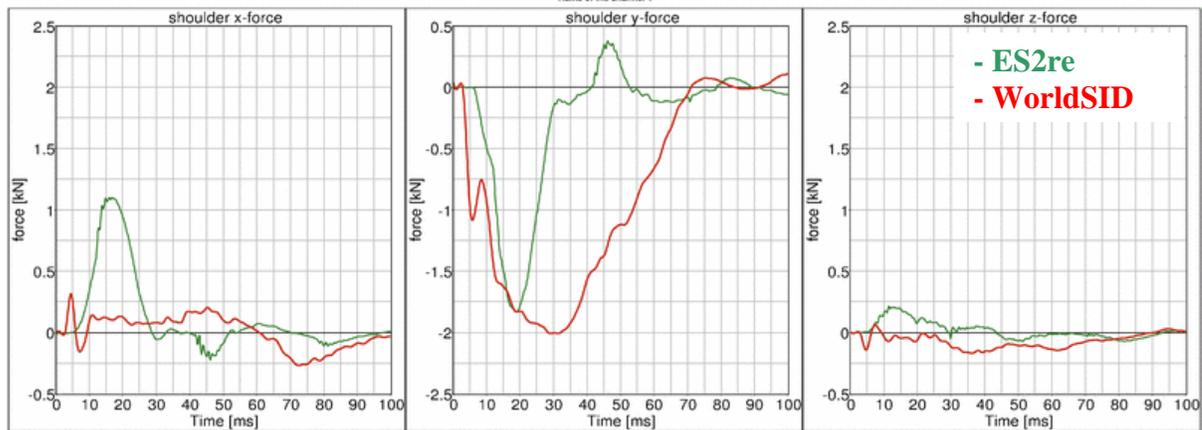

Figure 28: flat barrier 4 m/s; Shoulder force [kN] in x-, y- and z-direction vs. Time [ms].

The peak values of Head, T1 and T12 y-accelerations are very close together. Only the peak value of the ES2re pelvis is much higher than the WorldSID pelvis acceleration. A reason for this might be the different pelvis weights.

The rib deflections of the WorldSID for the three thorax ribs are also different. The first thorax rib of the WorldSID is about 50% higher than the ES2re upper rib. The second and third thorax ribs of the WorldSID are lower than the ES2re middle and lower rib deflections. This should be induced by a different arm kinematic of the two dummies.

The abdomen force of the ES2re seems to be consistent with abdomen rib deflections in the WorldSID and they show a similar behavior as in the abdomen pendulum test.

The last results of the sled test are the arm load cell results. The shoulder forces show also a different behavior of the arm for the ES2re and the WorldSID. The ES2re shoulder force increases at the beginning its x- and y- force. As the arm starts to slide on the sled and moves to the front of the dummy, the x-force decreases, thus also the y-force is decreasing and the sled hits directly the three ribs of the ES2re.

A completely different behavior is shown by the WorldSID. The construction of the WorldSID arm is different as described in the previous chapter. The arm can not rotate by a clavicle to the front of the Dummy. It is fixed at a shoulder rib. That is the reason why only the y-force of the WorldSID shoulder is increasing. It increases on nearly the same peak value as the ES2re y-shoulder force, but the unloading of the shoulder force is much slower, because the arm remains between the dummy and the sled.

This arm kinematic leads to the high first thorax rib deflection of the WorldSID. The arm remains between the first thorax rib and the sled.

This can also be observed in the following figures. Here the global kinematic is shown for the sled test results for selected time steps.

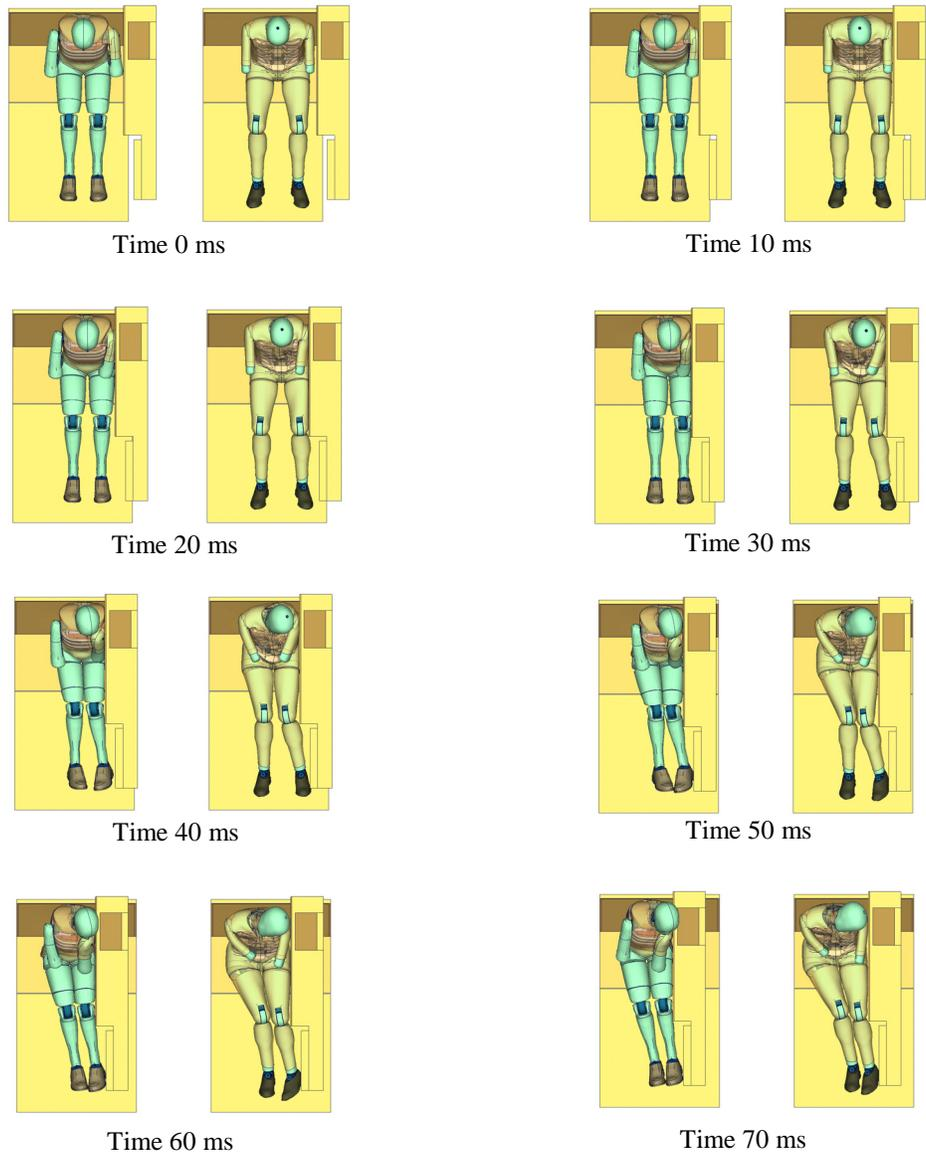

Figure 29: flat barrier 4 m/s; left hand side ES2re, right hand side WorldSID for times 0 - 70 ms

At a time of about 30ms is clearly to see, that the arm of the ES2re is moved frontwards and the WorldSID arm remains in position meanwhile the complete test.

Load paths in vehicle environment

In the following the two dummies are compared in a sedan car environment. The test setup and position of the ES2re is done for an oblique pole test. The WorldSID is then positioned in the same way into the vehicle. The next figures show the dummies in the seats and the door trims of the vehicle.

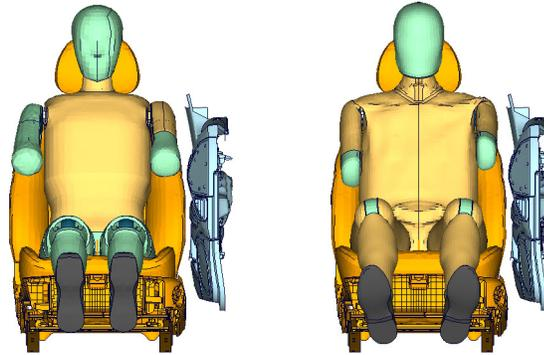

Figure 30: ES2re (left hand side) and WorldSID (right hand side) in vehicle with door trim and seat front view.

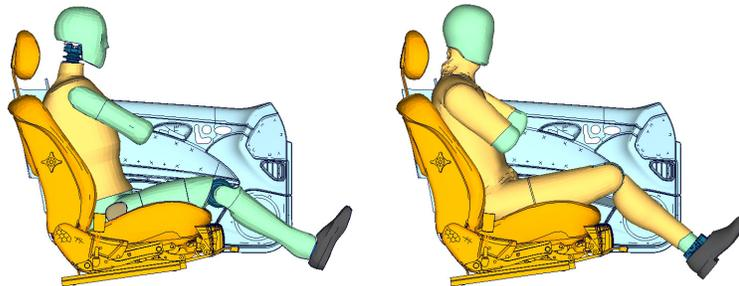

Figure 31: ES2re (left hand side) and WorldSID (right hand side) in vehicle with door trim and seat side view.

The absolute height of the door trim is about the same height than the arm joint of the ES2re. So the arm is not loaded completely by the door trim.
The armrest height is located in the area of the abdomen foam of the ES2re. This means also that the two abdomen ribs of the WorldSID are also loaded by the arm rest.

To understand the kinematics of the dummies the top view for different times is depicted in the following figure.

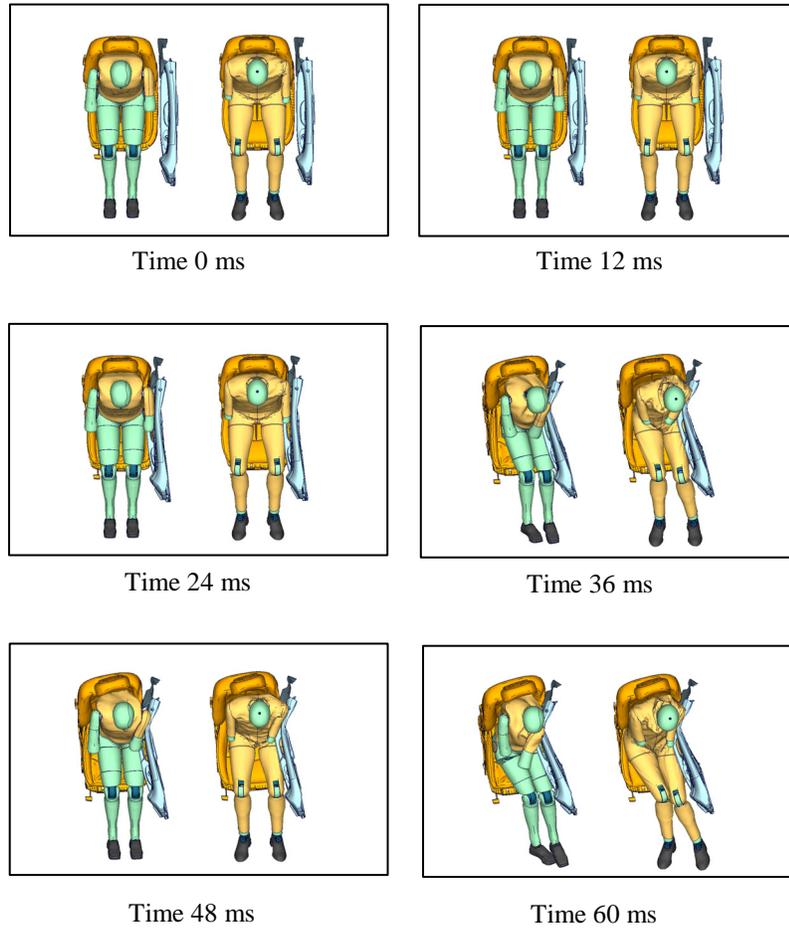

Figure 32: vehicle oblique pole; left hand side ES2re, right hand side WorldSID for times 0 - 60 ms

The same behavior than in the sled test is visible. The arm of the ES2re is rotating to the front of the Dummy and the WorldSID arm remains in position. This effect is also to see in the time history plots of the shoulder force in the next figure.

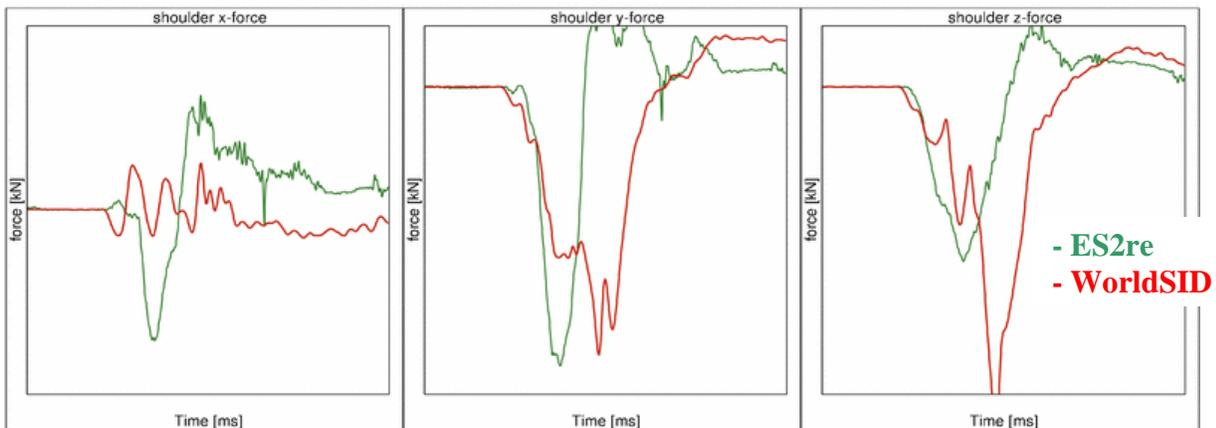

Figure 33: vehicle oblique pole; Shoulder force [kN] in x-, y- and z-direction vs. Time [ms].

The y-force of the ES2re has only a short peak value and decreases then back to nearly zero. This is the moment when the arm rotates to the front of the dummy. That is not the behavior the WorldSID shows. The arm remains between the ribs and door trim and a different behavior of the dummy occurs.

The next figure shows the influence of the arm kinematic on the thorax rib deflections.

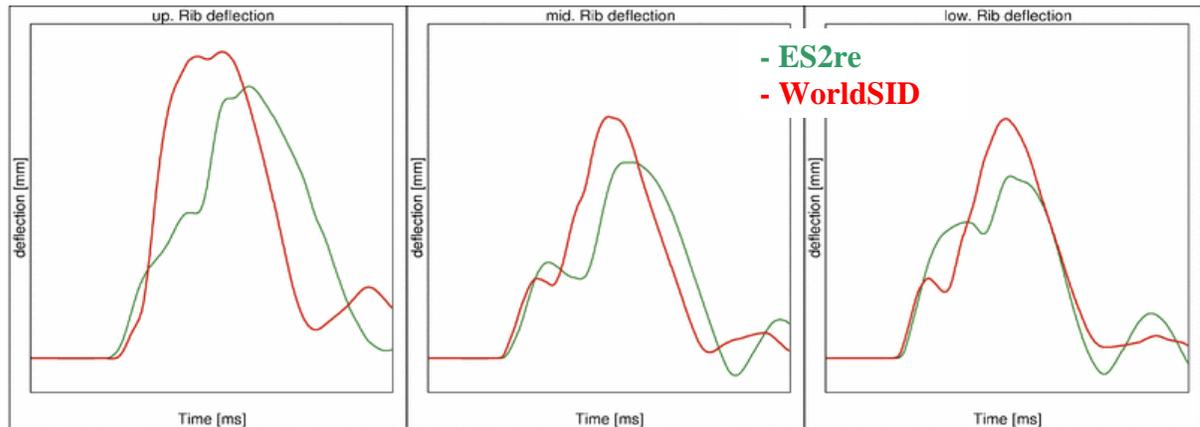

Figure 34: vehicle oblique pole; Upper, middle and lower thorax rib deflections [mm] vs. Time [ms].

The upper rib of the WorldSID is loaded faster and in a higher amount than the upper rib of the ES2re. This results from the arm kinematics of the WorldSID. The other two thorax ribs are loaded not quite different. This is the same observation which we made in the sled test.

Conclusion

The ES2re and the WorldSID are both 50% male dummies. The biofidelity of the WorldSID is increased compared to the ES2re.

The WorldSID is a completely new construction. Thus the geometric differences are in all body regions and the sitting height is a little bit smaller than for the ES2re.

For simple pendulum loads it seems that the ES2re overall shows a stiffer behavior than the WorldSID. The ribs of the ES2re show lower deflections for the same load and the abdomen foam of the ES2re seems to be harder than the WorldSID abdomen ribs.

The pelvis area behaves different. Here, the WorldSID pelvis flesh has a higher weight than the ES2re pelvis flesh. This gives an inert behavior to the WorldSID pelvis compared to the ES2re.

In the sled test the arm kinematics dominate the different behaviors of the dummies. The arm of the ES2re rotates with the clavicle to the front of the dummy. Thus first the shoulder is loaded and after rotating the arm to the front, all thorax ribs are loaded directly by the sled.

The WorldSID arm does not rotate to the front of the dummy. It remains between the ribs and the sled. This gives a higher load to the first thorax rib and a higher deflection.

A similar behavior can be observed for the vehicle test. Here also the arm kinematic dominates the different behavior of the dummies. But it can be pointed out that the WorldSID arm kinematic is easier to understand and not such complex as for the ES2re.

References

- [1] International Organization for Standardization: "ISO 15830-1; Road vehicles – Design and performance specifications for the WorldSID 50th percentile male side-impact dummy – Part 1: Terminology and rationale", Geneva, 2005.
- [2] Alexander Gromer, Sebastian Stahlschmidt, Peter Schuster: "WorldSID Dummy Model Development in Cooperation with German Automotive Industry", 10th International LS-DYNA Users Conference, 2008, Detroit.
- [3] U. Franz , S. Stahlschmidt, E. Schelkle, T. Frank: "15 Years of Finite Element Dummy Model Development within the German Association for Research on Automobile Technology (FAT)", JRI Japanese LS-DYNA Conference, 2008, Nagoya, Japan.
- [4] Christian Gehre, PDB – Partnership for Dummy Technology and Biomechanics: "DEVELOPMENT OF A COMPUTATIONAL MODEL OF THE WORLDSID 50TH MALE", Paper Number 09-0411, ESV Conference, 2009, Stuttgart.
- [5] A. Gromer, S. Stahlschmidt, R. D'Souza: "Development of the PDB WorldSID 50th Model with the German Automotive Industry", 7th European LS-DYNA Conference, 2009, Salzburg.