

An Investigation on the Roll-Over Crashworthiness of an Intercity Coach, Influence of Seat Structure and Passenger Weight

Kadir Elitok, Dr. Mehmet A. Guler, Bertan Bayram
*Product Development Dept., TEMSA A.S., TURKEY**

Dr.-Ing. Ulrich Stelzmann
*LS-DYNA Services, CADFEM GmbH, GERMANY***

**TEMSA A.S., Mersin yolu uzeri 10. km PK.480,
01323 Adana, TURKEY.
kadir.elitok@temsa.com.tr
www.temsa.com.tr*

***CADFEM GmbH, Geschaefsstelle Chemnitz, Cervantesstr. 89,
09127 Chemnitz, GERMANY.
ustelzmann@cadfem.de
www.cadfem.de*

Abstract

A roll-over event is one of the most crucial hazards for the safety of passengers and the crew riding in a bus. In the past years it was observed after the accidents that the deforming body structure seriously threatens the lives of the passengers, thus the roll-over strength has become an important issue for bus and coach manufacturers. Today the European regulation "ECE-R66" is in force to prevent catastrophic consequences of such roll-over accidents thereby ensuring the safety of bus and coach passengers. According to the said regulation the certification can be gained either by full-scale vehicle testing, or by calculation techniques based on advanced numerical methods(i.e. non-linear explicit dynamic finite element analysis). The quantity of interest at the end is the bending deformation enabling engineers to investigate whether there is any intrusion in the passenger survival space(residual space) along the entire vehicle.

In this paper, explicit dynamic ECE-R66 roll-over crash analyses of a stainless-steel bus under development were performed and the strength of the vehicle is assessed with respect to the requirements of the official regulation. Subsequently, different considerations which are not currently mentioned in the regulation (i.e. passenger and luggage weight) and some worst case assumptions such as the influence of the seat structure were investigated. The non-linear explicit dynamics code LS-DYNA as a solver and ANSA and LS-PREPOST softwares as FEA pre/post-processors were utilized throughout the bus roll-over analysis project. The FEA model was generated by using PCs running on Linux Suse operating system whereas the LS-DYNA solutions were performed on a multiple-processor workstation running on an AIX UNIX operating system.

During the first stage, a verification of the calculation procedure following regulation ECE-R66 was performed. The verification of calculation is a compulsory requirement of the regulation, as it is the technical service's responsibility(TÜV Süddeutschland in this case) to verify the assumptions used in the finite element analysis.

Keywords: *Roll-over, crashworthiness, ECE-R66, survival space, explicit dynamics, LS-DYNA*

Introduction

According to the literature surveys[1,2] on the pattern in bus and coach incident related injuries and fatalities, the roll-overs occurred in almost all cases of severe coach crashes. If we examine the bus and coach accidents in Europe:

Based on 47 real-world coach crashes with at least one “severe injury or passenger fatality”. Roll-overs and tipovers occurred in 42% of the cases [3]. Injury mechanisms in roll-over coach crashes were further analysed [4]. In the real-world crashes, 19% of the occupants were killed. The highest proportions were found in roll-overs over a fixed barrier, yielding a 30% rate of KSI(killed or seriously injured). In roll-overs without a fixed barrier, the KSI rate decreased to 14%. If the coach had an upper and a lower compartment then more than 80% of KSI were located in the upper section of the coach. The most severe injuries occurred during sliding over the outside ground after the roll-over. Spanish data from 1995–1999 showed a roll-over frequency of 4% of all coach “accidents” on roads and highways, and the risk for fatalities in a roll-over was five times higher than in any other coach “accident” type [5]. Among 48 touring coach crashes occurred in Germany, eight of them were roll-over/overturn crashes[6]. These eight crashes accounted for 50% of all severe injuries and 90% of all fatalities.

In case of a roll-over, passengers run the risk for being exposed to ejection, partial ejection or intrusion and thus exposed to a high-fatality risk [7]. The difference for a bus or coach passenger, with respect to biomechanics and space, as compared to those of lighter vehicle passenger becomes obvious in a roll-over crash. During a bus or coach roll-over, the occupant will have a larger distance from the centre of rotation as compared to that of a car occupant. For this reason, European regulation “ECE R66” titled “Resistance of the Superstructure of Oversized Vehicles for Passenger Transportation” is in force to prevent catastrophic consequences of such roll-over accidents thereby ensuring the safety of bus and coach passengers [8]. The roll-over of a bus is simulated using a full FEA program and the researchers [9-13] showed good agreement between the test and the analysis technique.

In this paper, ECE R66 calculation procedure performed for a TEMSA bus under is described. This 12.2 meters long bus is constructed with stainless-steel material and it has special reinforced roll-bar structure in the front and in the most rear. The FEA modeling is done by the specialized pre-processing software ANSA 11.3.5. and calculations are made by means of a non-linear, explicit, 3-D, dynamic FE computer code LS-DYNA. The calculation technique has been checked by verification of calculation tests applied on a breast knot of side-body and on a roof edge knot of the vehicle and subsequent numerical simulations were performed. A high degree of theoretical and experimental correlation is obtained, which confirms its validity. Once the method was assessed, a complete vehicle roll-over test simulation was carried out, and observing the deformation results with respect to the residual space it is inferred that the structure of the bus is able to pass the required regulations.

The ECE R66 Regulation

The purpose of the ECE R66 analysis is to ensure that the superstructure of the vehicle have the sufficient strength that the residual space during and after the roll-over test on complete vehicle is unharmed. That means no part of the vehicle which is outside the residual space at the start of

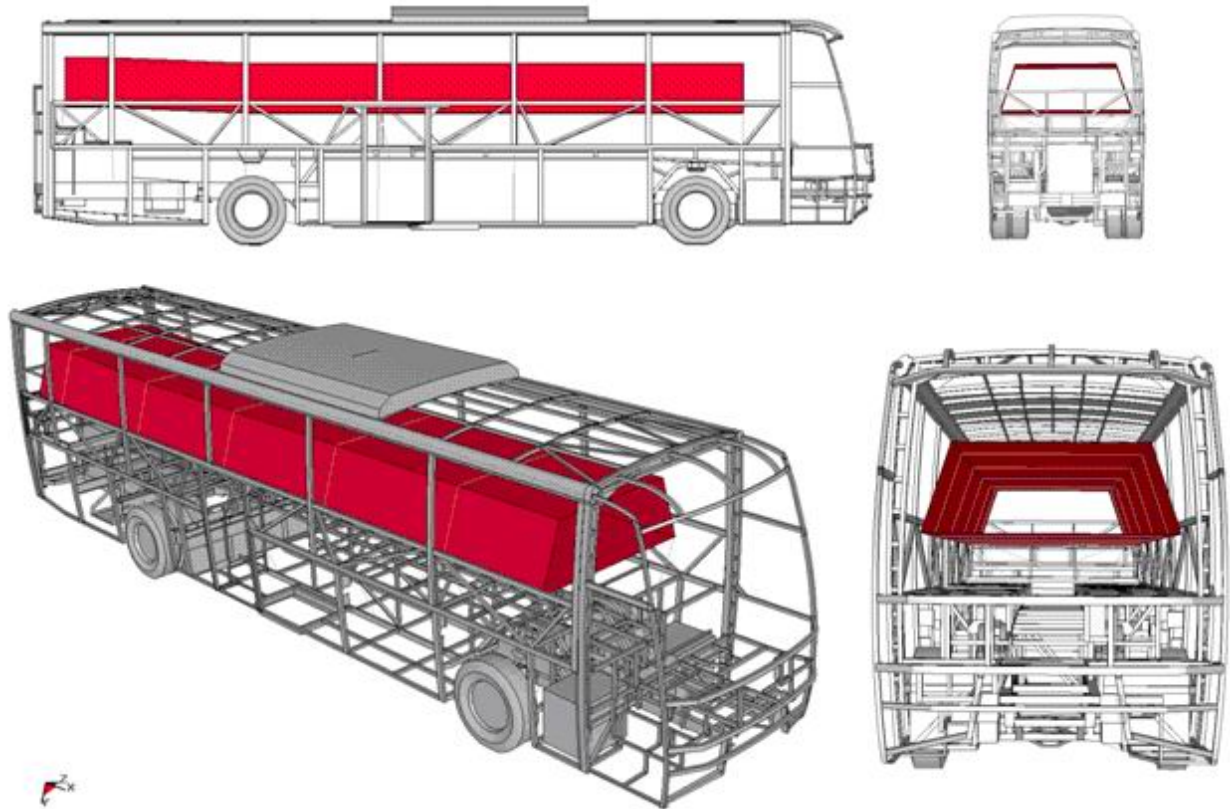

Figure 1. Residual space

the test (e.g. pillars, safety rings, luggage racks) are intruding into the residual space. In this test a given level of energy is transmitted to the superstructure of the bus.

The envelope of the vehicle's residual space is defined by creating a vertical transverse plane within the vehicle which has the periphery described in Figure 1, and moving this plane through the length of the vehicle.

The roll-over test is a lateral tilting test (see Figure 2) , specified as follows:

The full scale vehicle is standing stationary and is tilted slowly to its unstable equilibrium position. If the vehicle type is not fitted with occupant restraints it will be tested at unladen kerb mass. The roll-over test starts in this unstable vehicle position with zero angular velocity and the axis of rotation runs through the wheel-ground contact points. At this moment the vehicle is characterised by the reference energy. The vehicle tips over into a ditch, having a horizontal, dry and smooth concrete ground surface with a nominal depth of 800 mm

The roll-over test shall be carried out on that side of the vehicle which is more dangerous with respect to the residual space. The decision is made by the competent Technical Service on the basis of the manufacturer's proposal, considering at least the following:

the lateral eccentricity of the centre of gravity and its effect on the potential energy in the unstable, starting position of the vehicle; the asymmetry of the residual space; the different, asymmetrical constructional features of the two sides of the vehicle; which side is stronger, better supported by partitions or inner boxes (e.g. wardrobe, toilet, kitchenette).

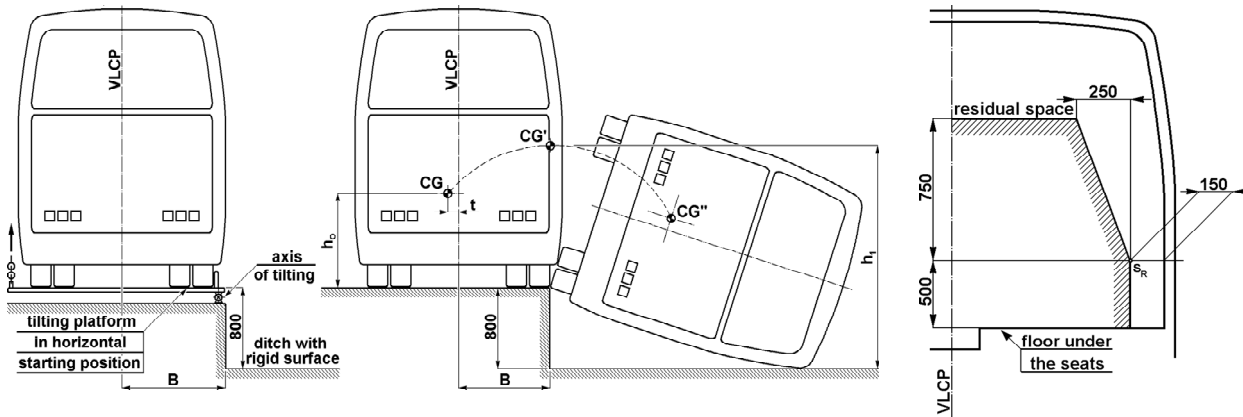

Figure 2. Roll-over test

Verification of Calculation

Before starting the ECE R66 simulation & certification process a verification of calculation procedure set forth by the regulation ECE R66 was performed. Two separate specimen (breast knot+roof edge knot extracted from the vehicle) were prepared and sent to TÜV Automotive for experimental investigations. These parts were subjected to certain boundary conditions and quasi-static loads at TÜV's testing facility. The same test scenarios were simulated by using LS DYNA. Force-deflection curves both for the experiment and simulation were compared and it was seen that there is a good correlation between experiment and simulation results (see Fig. 3 and Fig. 4).

Description of the Computational Model

FEA model of the full vehicle (With seats modeled) was comprised of some 870.000 first order explicit shell elements, 108 beam and 450.000 mass elements . Element length is assigned to be 10 mm in the critical regions (A verified assumption coming from the verification of calculation) and for the regions under the floor (lower structure-chassis) element length up to 40 mm was used. The number of elements per profile width is at least 3 for the upper structure, the number of elements per width is 4 for side-wall pillars which are significant for roll-over deformation.

All deformable parts were modeled with the 4-node Belytschko-Tsay shell elements with three integration points through the shell thickness [16]. The shell element formulation is based on Belytschko-Lin-Tsay formulation with reduced integration available in LS-DYNA [15]. This element is generally considered as computationally efficient and accurate. The shell element that has been, and still remains, the basis of all crashworthiness simulations is the 4-noded Belytschko and Tsay shell.

Upon completion of mesh generation of bare structure, masses were imposed according to a certain methodology. First, a list of masses of the vehicle was prepared . The engine, gearbox, air conditioner and fuel tank were roughly 3D modeled as rigid parts, the inertias were calculated analytically and mass and the inertia was imposed on a representative node (On the approximate center of gravity points for the relevant part) of these parts. The axles were modeled with rigid truss elements and the mass and the inertias were imposed using the same method. The masses

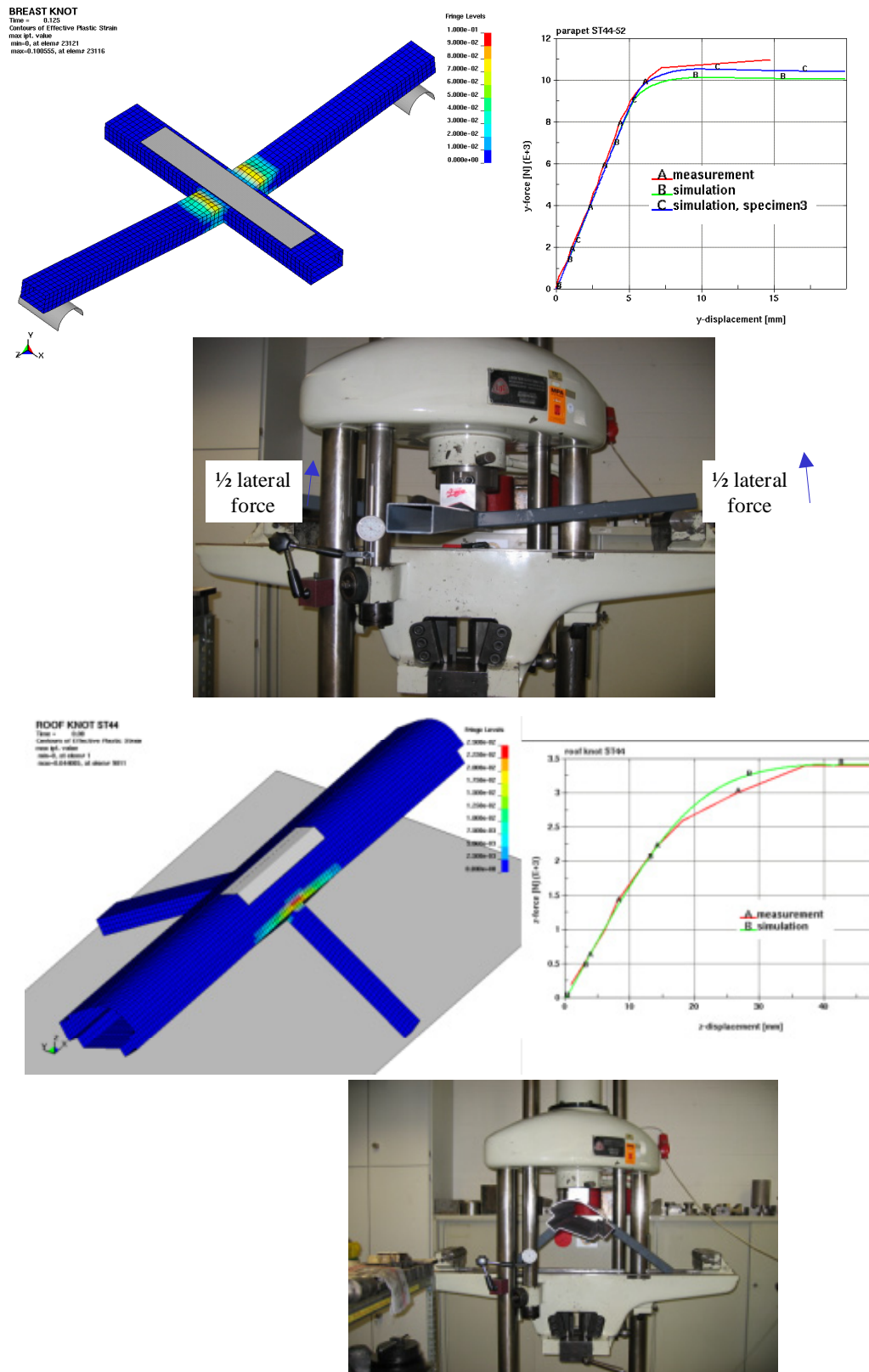

Figure 3. Test and Simulation applied on a breast knot and special roof profile-Results show high correlation

particularly located were imposed by using mass elements. The distributed masses were imposed by changing the density of the related region.

The “Center of Gravity (CoG)” of the vehicle was measured using a test platform in TEMSA. The measured values were in a good agreement with the ones coming from the FEA model. To exactly match the measured and calculated CoGs, the CoGs of engine, gearbox and the axles were fine tuned in the FEA model.

When it came to the definition of survival space in LS-PRE, the statement in the regulation ECE R66 was forming the basis of the survival space model. Through the whole vehicle, it was introduced to be 500 mm above the floor under the passengers’ feet, 150 mm from the inside surface of the side of the vehicle (The trim lengths were also considered and added on these values). The model of the survival space consists of rigid beam frames in each section (10 sections), rigidly mounted in the stiff region under the floor. There is no stiffness connection between these rigid beam frames because these shell elements are modeled with “Null material” for visualization only.

For obtaining the material data, tension tests were applied on several specimen at TÜV Automotive facilities. The true stress-strain curves were obtained and imposed in LS DYNA accordingly. The material model for the deformable structure in LS DYNA is the so called “MAT Type 24, Piecewise Linear Isotropic Plasticity model” [16]. This is an elastic plastic material model which uses the youngs modulus if stresses are below the yield stress and the measured stress-strain-curve if the stresses are above the yield stress. Rigid parts(engine,gear box,fuel tank, axles,etc) are modeled with the so called “Rigid Material, MAT Type 20 “. For the definition of the survival space (residual space) “MAT Type 9, Null Material” is used.

LS-DYNA Solution Procedure

The solution procedure in general is described as follows:

The total energy according to the formula indicated in the ECE R66 regulation:

$$E^* = 0.75Mgh$$

where M is the unladen kerb mass of the bus structure, g is the gravitational acceleration and $h = \Delta z = z_2 - z_3$ (see Fig.5).

This energy is applied to the structure by applying a rotational velocity to all of the deformable and rigid parts of the vehicle.

The h is the vertical distance between the CoG of the vehicle at free fall position (z_2) and the CoG of the vehicle which is kinematically rotated up to the ground contact position (z_3).

First the model is rotated around x axis until the mass center of the whole vehicle reaches its highest position. At this point the coordinate of the CoG in the z direction is recorded. Then the bus is rotated around the 100mm obstacle until the vehicle contacts the ground (An offset is left considering the shell thickness of the ground and the corresponding vehicle structural part) The

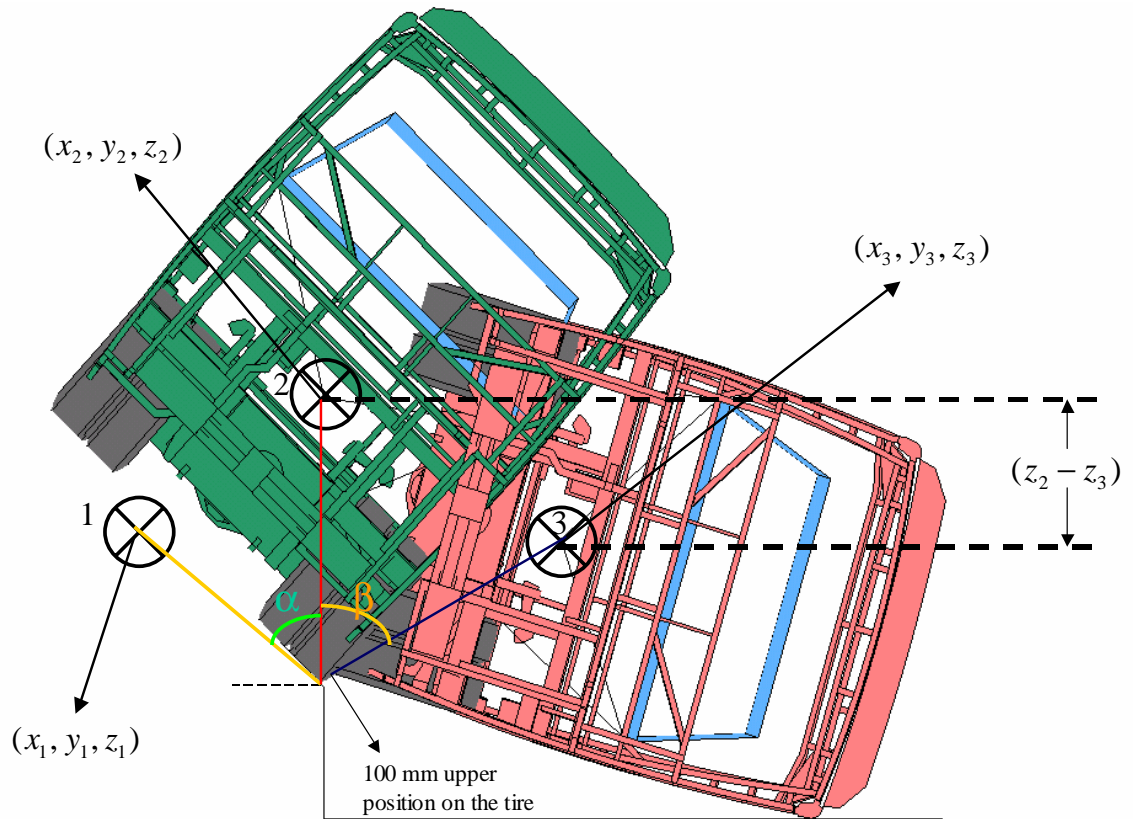

Fig. 4. Rotation of the bus to the ground contact position

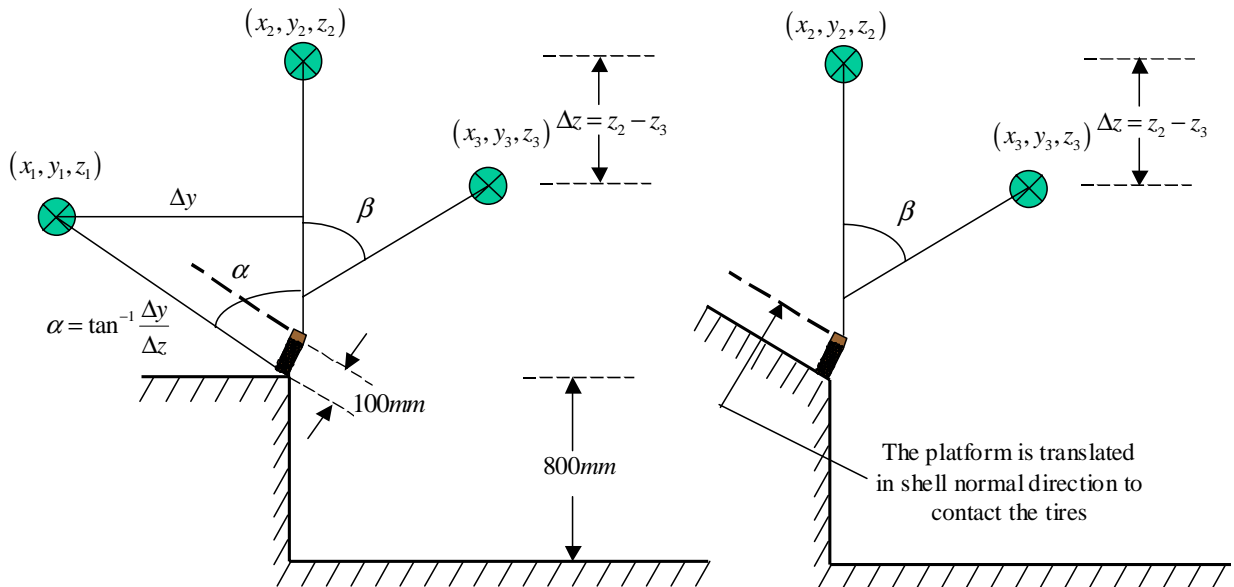

Fig. 5. Rotation of the CoG of the bus

z coordinate of the CoG at this position is recorded as well. Then the vertical distance between these 2 points is determined(h).

Initial Velocity Generation is done with *INITIAL_VELOCITY_GENERATION[16] card. The contact type *CONTACT_AUTOMATIC_NODES_TO_SURFACE was used between the vehicle super-structure (body-in-white) and the ground whereas *CONTACT_AUTOMATIC_SURFACE_TO_SURFACE was used between the seat structure and the seat rails on the side-wall and on the sill. The static friction coefficient between all parts was set to 0.1 and the dynamic friction coefficient was set to default which assumes that it is dependent on the relative velocity v -rel of the surfaces in contact. Shell thickness change option in *CONTROL_SHELL[16] is enabled assuming that membrane straining causes thickness change during the deformation.

Mass scaling was applied to the smallest 100 element which resulted in negligible change in overall mass and a good time saving in the total elapsed time. Objective Stress Update(OSU) option which is generally applied in explicit calculations for only those parts undergoing large rotations is turned on.

The solutions are performed with SMP version of LS-DYNA. The analysis time interval was set to 300 ms, with results output required after every 5000 time-steps. The analyses run ≈ 20 – 25 h on an AIX IBM P5+ series workstation with 4 P5 processors.

Scenarios Investigated

At this stage non-linear explicit dynamic solutions were performed for 4 different scenarios in LS-DYNA. The Scenarios are:

1. The baseline vehicle (BIW of the vehicle modeled with no seats, no passenger and no luggage mass introduced. This is the analysis convention according to the current ECE-R66 regulation.)
2. The vehicle with the seat structure introduced (To see the effect of seat structure)
3. The vehicle with seat structure and passenger mass introduced(Assuming that all the passengers are restraint with safety belts- The prospective future of the regulation). The passenger mass was imposed on the seat structure assuming that single passenger mass is 68 kg and the number of passengers on board was considered to be 42.
4. The vehicle with seat structure, passenger mass and luggage mass in the luggage compartment introduced. (Assuming that this is the most realistic case). The density of the luggage considered to be 100 kg/m^3 resulting 1000 kg in total.

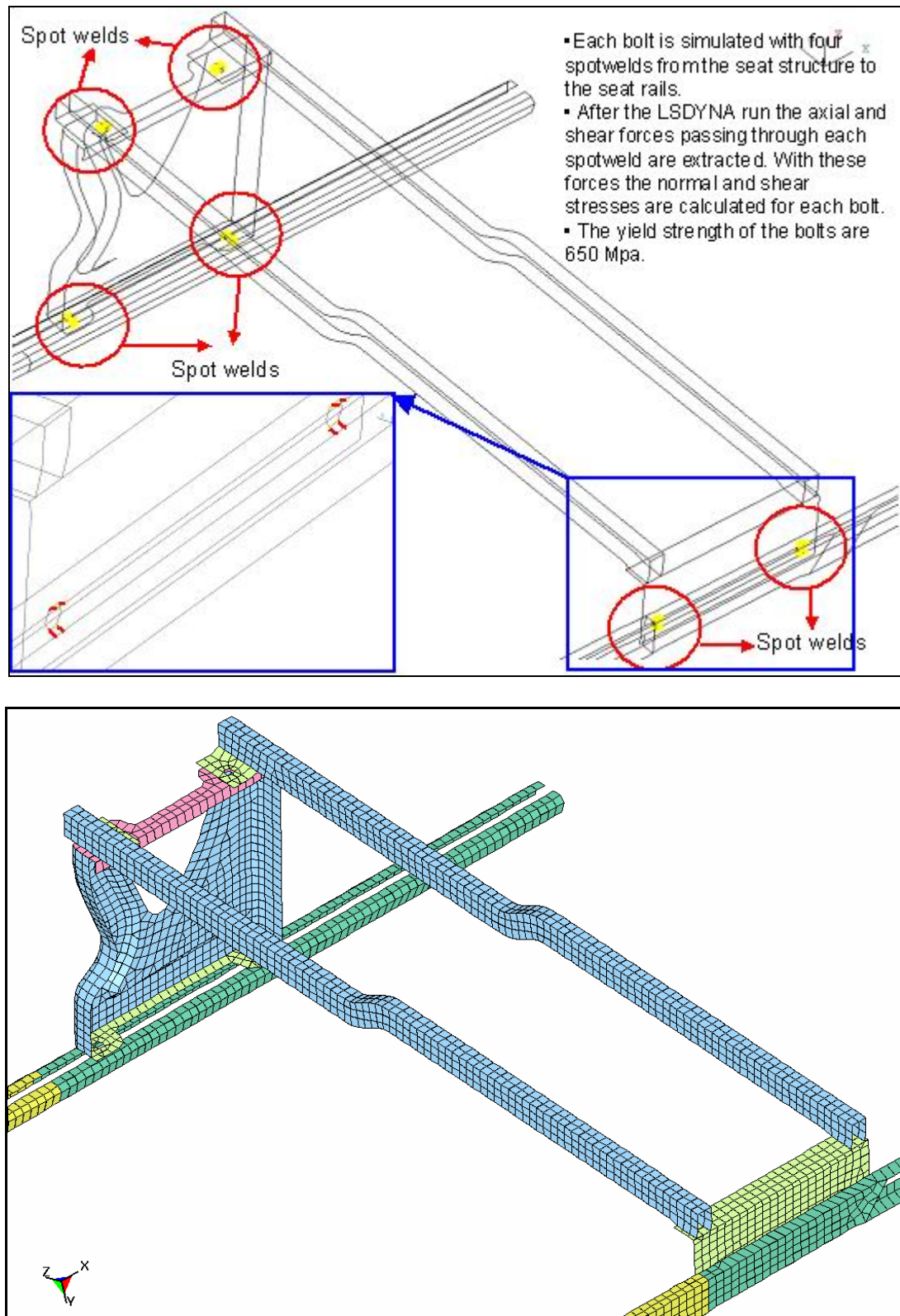

Fig. 6. FEA Model of the seat structure

Results

In Figure 7 a general overview of the simulation results for selected time steps are illustrated. The bus first comes into contact with the ground and then starts absorbing energy by elasto-plastic deformation and bends at the plastic hinge zones. After sufficient deformation occurs the bus starts sliding.

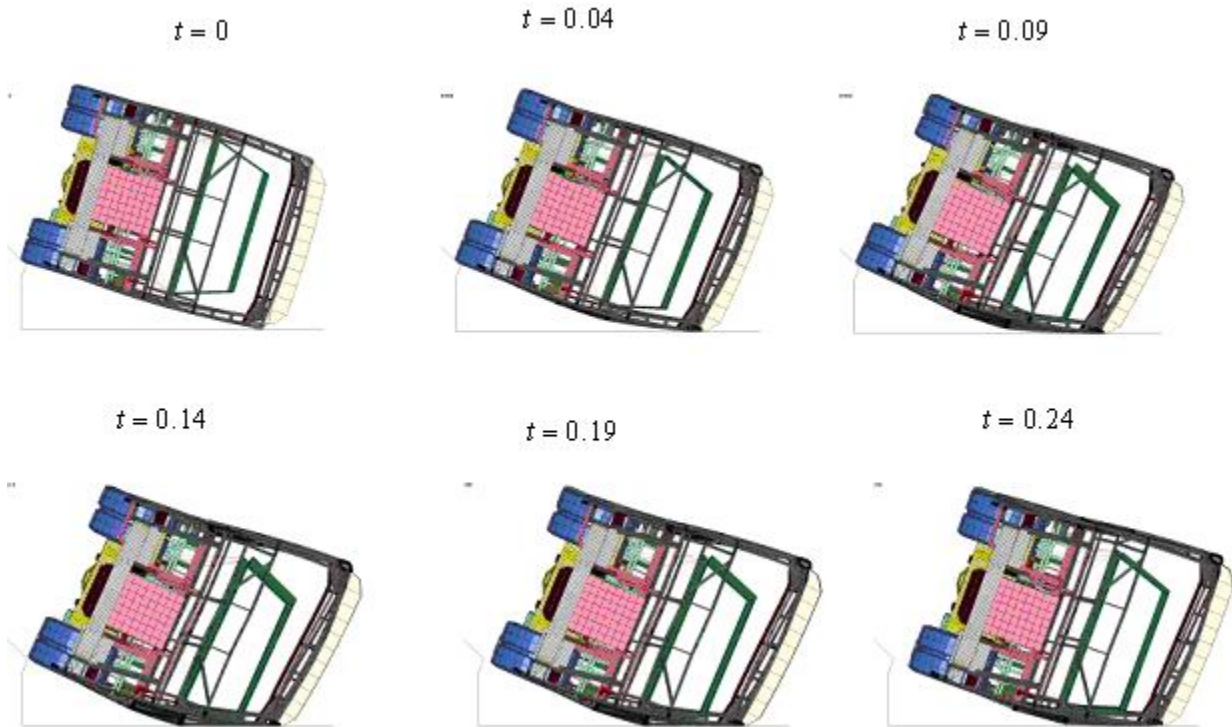

Figure 7. Results overview through the time steps

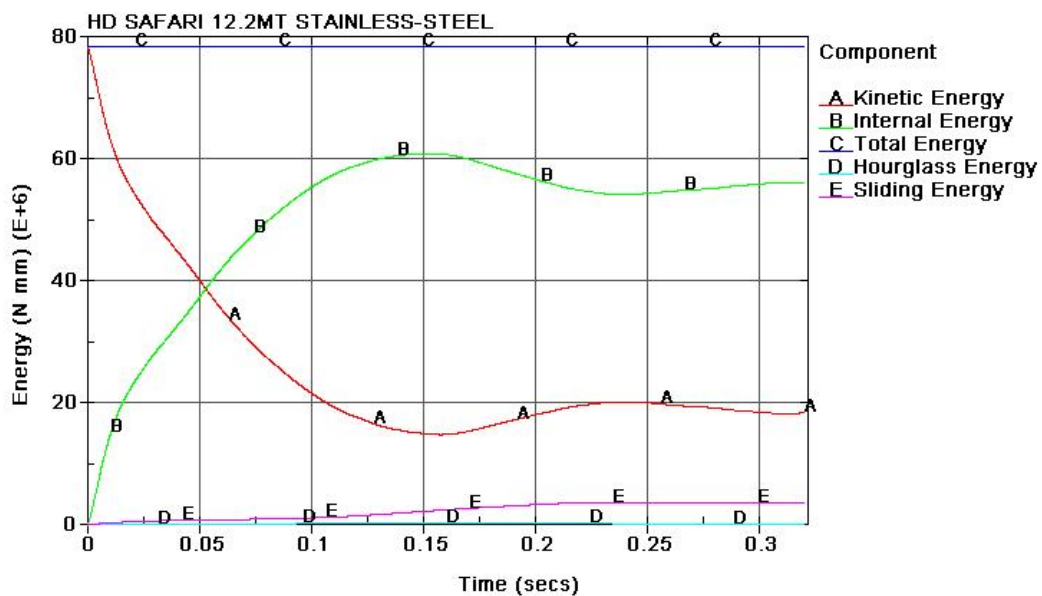

Figure 8. Energy distribution versus time

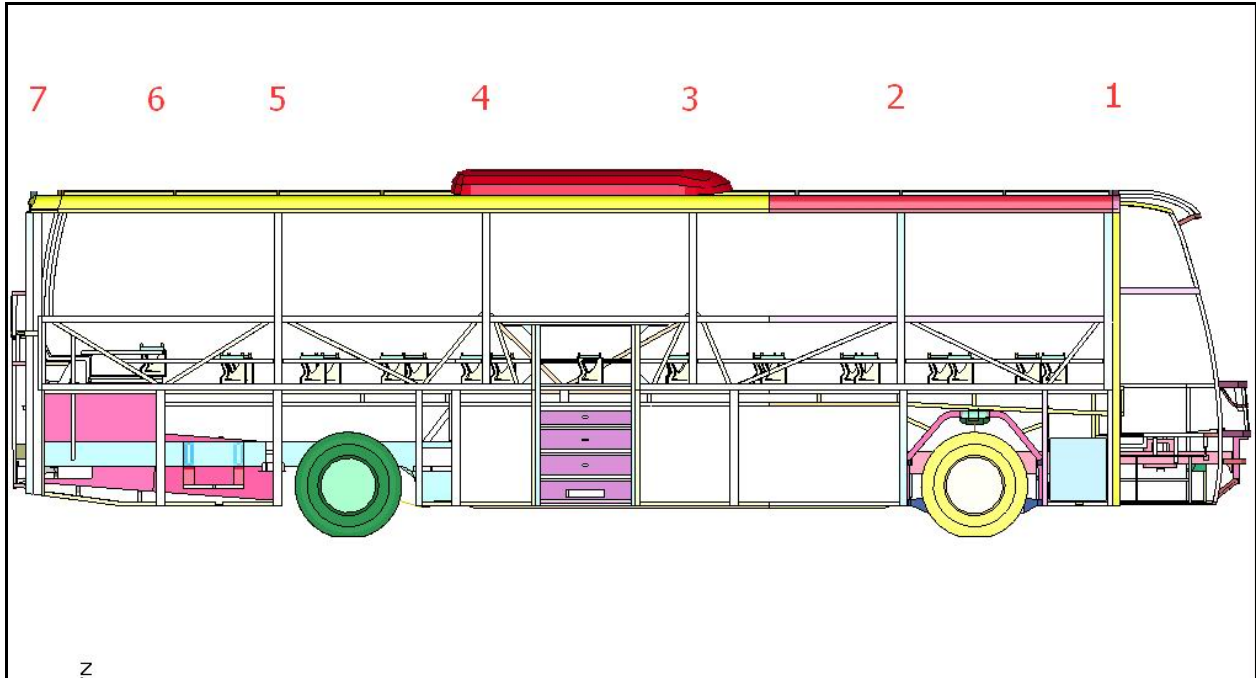

Figure 9 - Section Definition for ECE R66 Analysis

In figure 8 the energies maybe observed; the total energy remains to be constant which is one of the indications for correct analysis results. It can be observed that the kinetic energy drops and transforms into internal energy (Strain energy + sliding energy) over the time and the hourglass energy remains negligible.

After each analysis the deformation behavior (at time step when it reaches the maximum deformation amount) is investigated for each section(see Figure 9) throughout the vehicle. The shortest distance between the pillar and the survival space in the corresponding section is observed and recorded.

For comparing the deformation behavior of 4 scenarios in general a representative section (Section 2) is considered and for each scenario the bending deformation is illustrated in Figures 10 – 13 below.

For the baseline vehicle, it can be seen that the shortest distance between the survival space and the pillar at section 2 is found to be 46 mm at the bottom corner and 72 mm at the upper corner at time 128 msec which comfortably satisfies the requirement of ECE-R66 (see Figure 10).

For scenario 2, adding the seat structure in the model strengthens the body structure and this in turn increases the shortest distance between the survival space and the pillar at section2 by 9.9 mm at the bottom corner and by 14.5 mm at the upper corner respectively.

HD SAFARI 12.2MT STAINLESS-STEEL-BASELINE
Time = 0.128

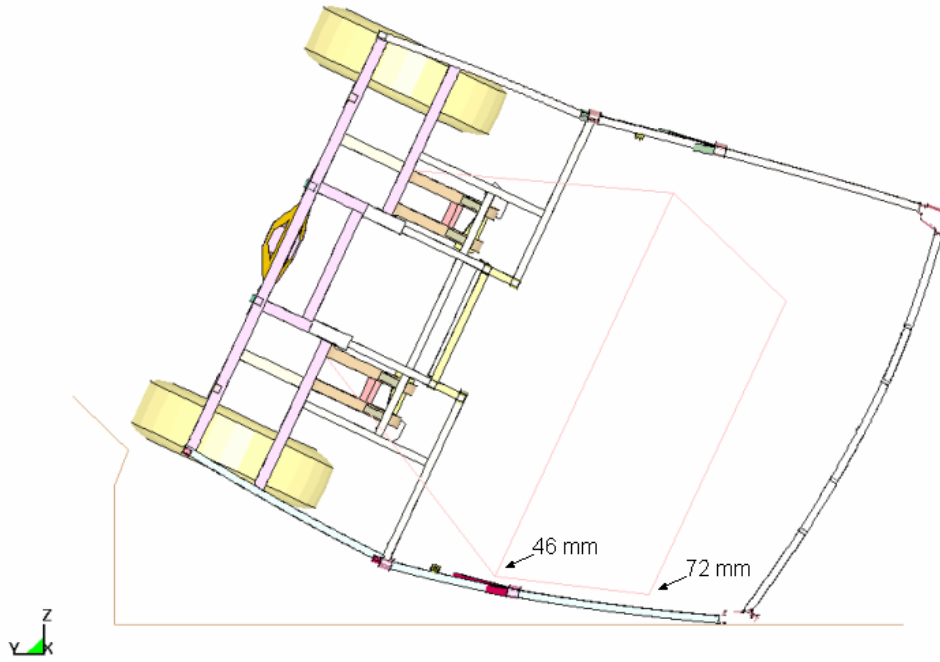

Figure. 10 Deformation plot of section 2 for Scenario 1

HD SAFARI 12.2MT STAINLESS-STEEL
Time = 0.128

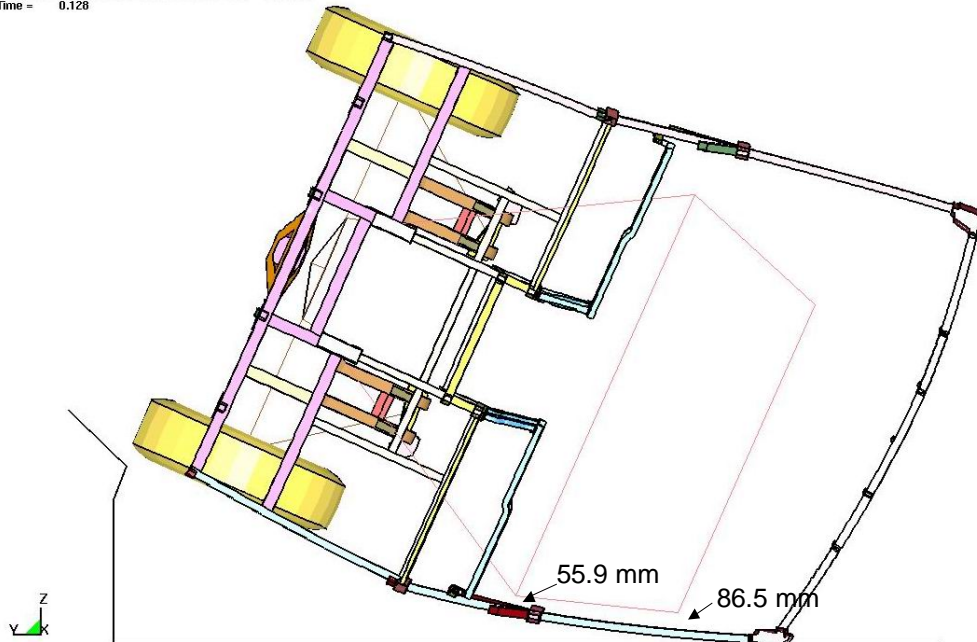

Figure. 11 Deformation plot of section 2 for Scenario 2

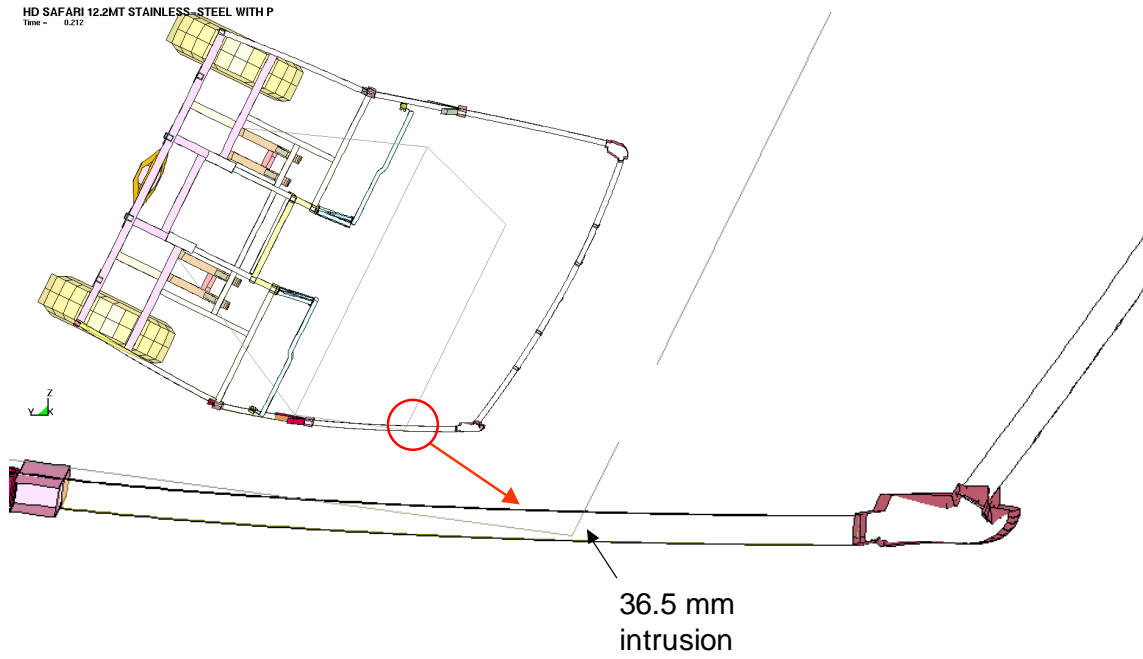

Figure. 12 Deformation plot of section 2 for Scenario 3

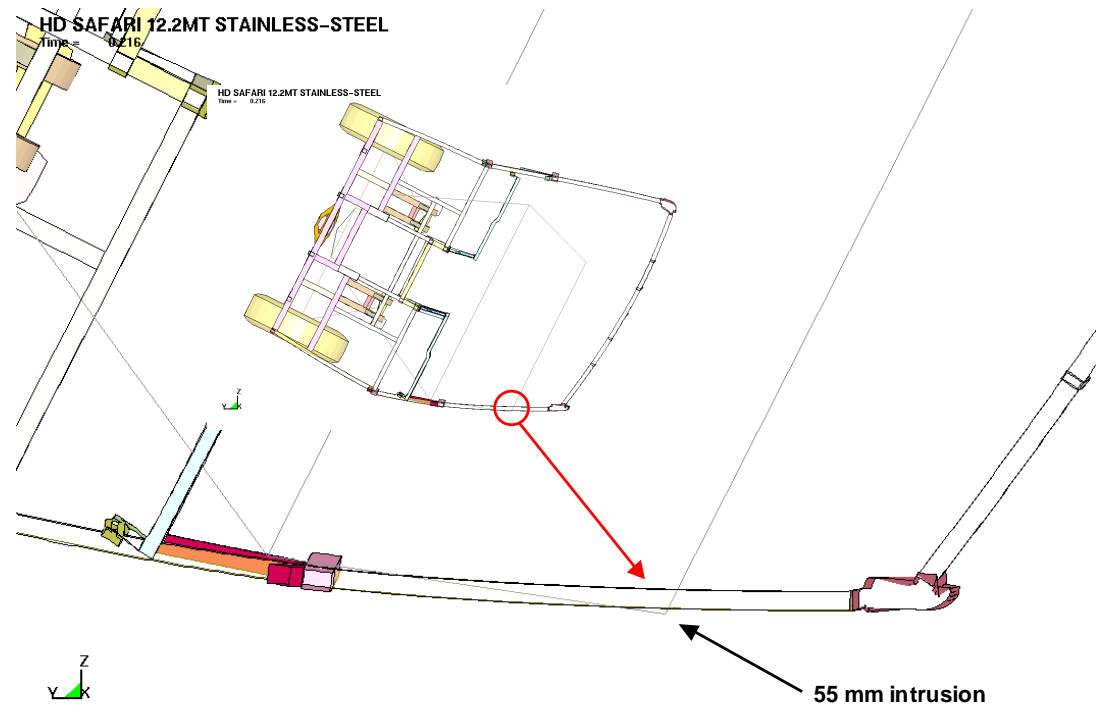

Figure. 13 Deformation plot of section 2 for Scenario 4

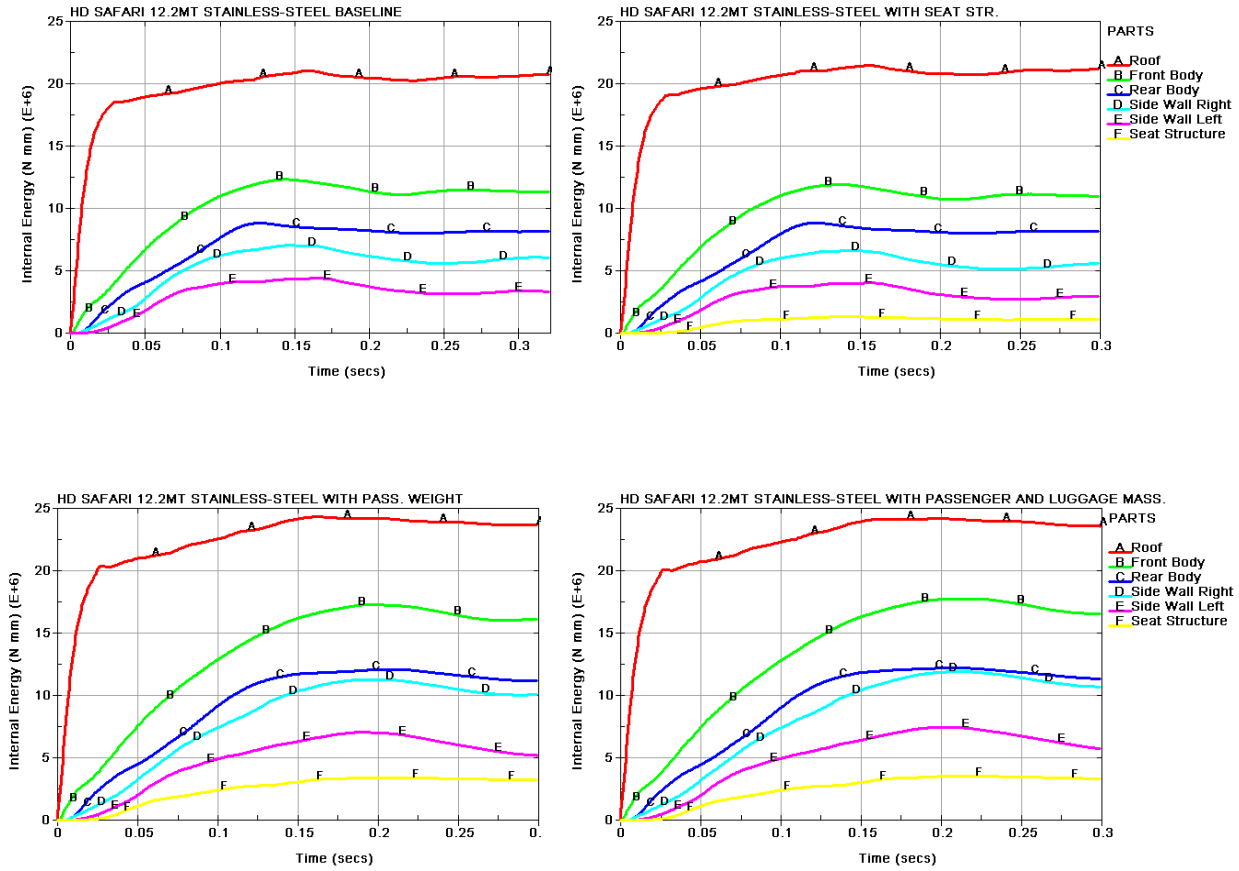

Figure. 14 Deformation plot of section 2 for each scenario

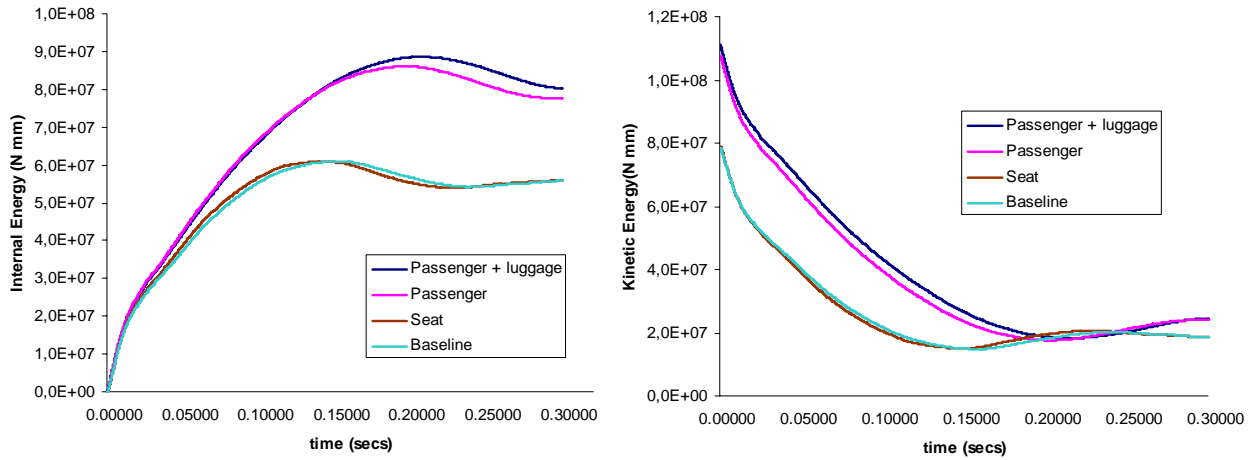

Figure. 15 Internal and Kinetic Energy distribution over time

Table 1 – Mass CoG and Imposed Energy for Each Scenario

	Mass kg	CoG mm	Energy Joules
Baseline	13100	1225,4	78500
With Seats	13100	1220,7	78700
With Passenger weight	15956	1325,4	107700
With Passenger + Luggage	16913	1300,8	111000

For scenario 3, when the 42 passengers mass ($42 \times 68 = 2856$ kg.) introduced on the seat structure, the total mass of the vehicle becomes 15956 kg and center of gravity of the bus shifts up by 104.7 mm (see Table 1). Applied energy to the system increases by almost 30 kJ which is an increase of 37 %. We can see that there is a 36.5 mm intrusion to the survival space in Figure 12.

For scenario 4, when the vehicle with seat structure, passenger mass and luggage mass (in this case 957 kg) in the luggage compartment introduced, total mass of the vehicle becomes 16913 kg. Introducing the luggage mass decreases the center of gravity by 24.6 mm, the total energy applied to the system increases by 3.3 kJs. It can be seen that the intrusion further increases by 18.5 mm.

Figure 14 gives the energy absorption rates for each part in the vehicle. Since first the roof profile comes into contact with the ground and experiences significant elasto-plastic strain (Crushing), it absorbs the maximum energy. The second and third highest energy absorbers are the front and rear body respectively. They are stiffened by the roll-over resistant structures called roll-bars. The fourth and the fifth highest energy absorbers are the side wall on the right and the side wall on the left respectively. Seat structures are also absorbing significant energy helping the pillars to yield less deformation.

Figure 15 shows the internal and kinetic energy distribution for each scenario. The highest internal energy was seen in scenario 4.

Conclusions

Computational nonlinear explicit dynamic analysis was employed for evaluation of the roll-over deformation behavior under test vehicle impact conditions. The used computational model provided comparable results to experimental measurements and can thus be used for computational evaluation of other type of bus and coach vehicles in order to avoid numerous expensive full-scale crash tests. The tests have also shown that the new safety roll-bar structure assures controllable crash energy absorption which in turn increases the safety of vehicle occupants.

In this study the roll-over behavior of a bus vehicle under 4 different scenarios have been investigated. In order to see the effect of seat structure, analysis with seat structure were performed and it was seen that the seat structure has a positive effect of about %20 on bending deformation behavior.

The analysis of the real world accidents indicated that the partial or total ejection is a severe injury mechanism. The injury severity of the casualties is less if the bus is equipped with a seat restraint system. The investigations indicated that the introduction of belted passengers increases the energy to be absorbed during rollover significantly. The influence of the belted occupants must be considered by adding a percentage of the whole passenger mass to the vehicle mass. That percentage depends on the type of belt system and is 70% for passengers wearing 2-point belts and 90% for passengers wearing 3-point belts[17]. Considering these facts the total mass (%100) of the passengers was included in the analysis model which is scenario 3 of our analyses. The current ECE-R66 regulation does not consider the mass of the passengers, however, the expert meetings show that in the future passenger mass will also be included in the regulation. Therefore the main purpose of this study was an attempt to understand the consequence when the passengers mass is imposed on the seat structures. It is seen that the input energy is 37% greater than the baseline which severely impacts the roll-over behavior of the pillars. When the vehicle is fully loaded(including luggage mass, scenario 4) the situation gets even worse. Even though center of gravity of the vehicle is lowered, the total mass increases which in-turn gives the maximum intrusion.

References

1. Albertsson, P. and Falkmer, T., "Is there a pattern in European bus and coach incidents? A literature analysis with special focus on injury causation and injury mechanisms", *Accident Analysis & Prevention* Volume 37, Issue 2, 2005, pp. 225-233.
2. "Evaluation of Occupant Protection in Busses", Rona Kinetics and Associates Ltd., North Vancouver, BC, Canada, Report RK02-06, 2002.
3. Botto P., Caillieret M., Tarrier C., Got C. and Patel A., "Evaluation of restraint system for coach passengers", 14th International Technical Conference on Enhanced Safety of Vehicles, Munich, Germany, 1994.
4. Botto P. and Got C., "Vehicle rollover and occupant retention", 15th International Technical Conference on the Enhanced Safety of Vehicles, Melbourne, Australia, 1996.
5. Martínez L., Aparicio F., García A., Páez J. and Ferichola G., "Improving occupant safety in coach rollover", *Int. J. Crashworthiness*, 8,2003 (2), pp. 121-132.
6. Rasenack W., Appel H., Rau H. and Rietz C., "Belt systems in passenger coaches", 15th International Technical Conference on the Enhanced Safety of Vehicles, Melbourne, Australia, 1996.
7. "Evaluation of occupant protection in buses", Transport Canada, Road Safety and Motor Vehicle Regulation (ASFBE), Ottawa, Canada, 2002.
8. Klose, G.L., "Engineering basic of roll over protective structures", SAE Paper 690569.
9. Kumagai K., Kabeshita Y., Enomoto H., and Shimojima S., "An Analysis Method for Rollover Strength of Bus Structures", 14th International Technical Conference on Enhanced Safety of Vehicles, Munich, Germany, 1994.
10. Niii N. and Nakagawa K., "Rollover Analysis Method of a Large-Sized Bus", 15th International Technical Conference on the Enhanced Safety of Vehicles, Melbourne, Australia, 1996.
11. Castejon L., Miravete A. and Larrodé E. " Intercity bus rollover simulation", *International Journal of Vehicle Design*, Vol. 26, No 2/3, 2001.
12. Elitok K., Güler M. A., Avci F.H. and Stelzmann U., "Bus Rollover Simulation, Validation of a new Safety Concept", 23rd CADFEM Users' Meeting , International Congress on FEM Technology, Bonn, Germany, 2005.
13. Elitok K., Güler M. A., Avci F.H. and Stelzmann U., "Regulatory Bus Roll-Over Crash Analysis Using LS-DYNA", "Conference for Computer-Aided Engineering and System Modeling", İstanbul, Turkey, 2005.
14. Belytschko T.B., Lin J.I., and Tsay C.S., "Explicit Algorithm for the Nonlinear Dynamics of Shells", *Comp. Methods. in Applied Mechanics and Engineering*, Vol. 43, pp. 251-276, 1984.
15. Livermore Software Technology Corporation, LS-DYNA theoretical manual; 1998.
16. Livermore Software Technology Corporation, LS-DYNA keyword user's manual; 2001.
17. Mayrhofer E., Steffan H. and Hoschopf H., "Enhanced Coach and Bus Occupant Safety", Paper Number 05-0351, Graz University of Technology, Vehicle Safety Institute, Austria

