

## **Deformable Rigid Bodies in LS-DYNA with Applications – Merits and Limits**

### **Authors:**

Johann Bitzenbauer, Institute for Mechanics, University Karlsruhe, Germany  
Ulrich Franz, DYNAmore GmbH, Stuttgart, Germany  
Karl Schweizerhof, Institute for Mechanics, University Karlsruhe / DYNAmore  
GmbH

### **Correspondence:**

Karl Schweizerhof, Institute for Mechanics,  
University Karlsruhe, D-76128 Karlsruhe, Germany  
DYNAmore GmbH, Industriestr. 2, D-70565 Stuttgart, Germany

Telephone +49 711 459600-0  
Fax +49 711 459600-29  
karl.schweizerhof@dynamore.de  
karl.schweizerhof@ifm.uni-karlsruhe.de

### **Keywords:**

modal methods, deformable rigid bodies, transient dynamics

---

**ABSTRACT**

Modal methods are long known in linear dynamic analysis for efficient computations of the response of structures. The mechanical idea behind is to find a particularly useful problem dependent basis (so called eigenfunctions or eigenmodes) which can be separated into some of major importance for the behavior of the structure and others of minor interest (which can be subsequently disregarded). Unfortunately this concept is basically a completely linear one. However, more recent versions of LS-DYNA offer the possibility to superimpose shape functions from a previously computed eigenmode basis with a nonlinear rigid body motion for parts of the structure. This allows to consider at least some of the elastic behavior of a body which would be otherwise considered completely rigid. The resulting displacements are then computed with standard explicit methods, allowing on one side a substantial reduction of the number of degrees of freedom and on the other side parts of the system can be still computed in a fully nonlinear manner. The method has been presented in [1]. In the current contribution, two different practical applications, a head impact problem and a deep drawing simulation are presented and compared to a fully nonlinear solution.

**INTRODUCTION**

Using modal analysis, the reaction of a structure can be written as a sum of the reaction of a set of *modes* instead of a set of *nodes* in classical explicit or implicit methods. The unknowns are the modal amplitudes instead of nodal displacements. Disregarding numerical problems, if a complete set of modes is used, the response is computed exactly – though it must be said that in practice this is only possible for problems with a fairly small numbers of degrees of freedom. To our opinion, the main practical use of the proposed technique is for structures with large numbers of degrees of freedom, in which for reasons of computational efficiency some parts have to be set rigid. Treating them fully deformable thus with a complete FE discretization would increase calculation time tremendously.

These “rigid parts” can now be declared as so called deformable rigid bodies. This means that deformations of a previously determined eigenmode basis are superimposed on the nonlinear rigid body motion. Without having the aim to get the “exact” solution too close, this substantially improves the quality of the solution in comparison with the rigid body solution, at only moderately higher costs.

Of course the superposition principle assumes linearity and thus only problems of small strain can be treated. Flexible rigid bodies were implemented in a more recent version of LS-DYNA to superimpose shape functions from a previously computed eigenbasis on a nonlinear rigid body motion for parts of the structure, while treating others as fully nonlinear.

Such a strategy is particularly useful, when fairly large structures, which show a strong rigid body motion and/or only little deformation, are contacting structural parts which show large deformations. Typical examples are head impact simulations, where a head model is impacting deformable parts and metal forming simulations, where large very stiff machines respectively machine parts are deforming a blank. In [1] such a technique has been used for a large ship structure under a mine attack.

### Basic Procedure with LS-DYNA

In the following, we will describe all necessary steps to prepare a LS-DYNA keyword file for modal analysis. Our report mainly follows [1], but we only focus on eigenmodes – which have a more clear mechanical meaning than the constraint and attachment modes also discussed there. We will give only a rough description with some additional remarks. For more details we refer to [1].

The general procedure is as follows: First identify all parts we want to treat in the mentioned way as rigid bodies with superimposed modes. For them, the eigenvalue problem

$$(\mathbf{K} - \omega^2 \mathbf{M}) \Phi = \mathbf{0}$$

is solved to get the  $n$  eigenmodes wanted. Their orthogonality property

$$\Phi^T \mathbf{M} \Phi = \mathbf{I} , \quad \Phi^T \mathbf{K} \Phi = [\omega^2]$$

is used to reduce the size of the system

$$\mathbf{M} \ddot{\mathbf{u}} + \mathbf{K} \mathbf{u} = \mathbf{f}(\mathbf{t})$$

to

$$\mathbf{I} \ddot{\mathbf{z}} + [\omega^2] \mathbf{z} = \mathbf{p}(\mathbf{t}) .$$

The fewer eigenmodes are used, the smaller is the reduced size in comparison with the original system. We prefer eigenmodes, because they offer a natural basis for the equations of motion and due to this the resulting system becomes diagonal. It can be treated with any time integration scheme thus also explicit time integration. In the case of constraint or attachment modes, however, the resulting system is described by densely populated matrices.

After solving the explicit equations, the full system solution is again recovered via

$$\mathbf{u} = \Phi \mathbf{z} , \quad \ddot{\mathbf{u}} = \Phi \ddot{\mathbf{z}} , \quad \mathbf{p}(\mathbf{t}) = \Phi^T \mathbf{f}(\mathbf{t})$$

and the resulting deformations are superimposed onto the centre of mass of the rigid body.

This last fact has a serious consequence for Dirichlet boundary conditions. Their *absolute* specification in the later described input deck for the eigenvalue analysis will turn into a *relative* one in the local coordinate system of the rigid body. Thus all elements with Dirichlet data necessarily must be kept outside the rigid body. This inconvenient situation can be solved in practice in two ways:

- (i) Exclude all elements with Dirichlet data from the flexible rigid body by giving them an own part ID. Then the Dirichlet data from the original input deck can be taken into the new analysis one to one. Of course, these elements must be excluded from the eigenvalue analysis.
- (ii) If possible, we can add some additional new elements to the structure with new part ID and apply then the Dirichlet conditions to them. This is to our opinion the more preferable procedure, because the same eigenmode data base can be used for several different cases of boundary conditions.

### Creation of an input deck

Now we will describe how to prepare an LS-DYNA input deck according to the above. For all investigations a double precision version of LS-DYNA must be used. First, create sub-models from the original input deck for each flexible rigid body. In simple cases this can be done with the help of the SelPar button in LS-PREPOST. The Output button can be used to write the remaining nodes and elements into a new keyword file. All applied loads must then be removed. If we have constraints between different parts of our system, we include them in the eigenvalue analysis. In [1] it is written, that enough boundary constraints must be defined to eliminate rigid body motion. However, we prefer another procedure described below and suggest *to remove all boundary constraints* except the ones who shall describe constraints in the local relative coordinate system of the rigid body. (The last case is only given for completeness; maybe it has little practical meaning.)

The implicit method is then activated by the `*CONTROL_IMPLICIT_GENERAL` keyword. We set `imflag=1` and define an arbitrary initial implicit time step size `dt0>0`. The eigenvalue analysis is activated by the `*CONTROL_IMPLICIT_EIGENVALUE` keyword. We must specify the number of eigenmodes `neigv` to be computed. By default, the lowest `neigv` eigenvalues are computed. We suggest to perform a preliminary analysis of approximately 15 or 20 eigenvalues first. They are written to the `d3eigv` file. Generally we should inspect this file with LS-PREPOST. In the suggested case of no boundary constraints, the first six eigenmodes will describe the rigid body motions in 3D. Their eigenfrequencies are very close to zero in comparison to the eigenfrequency of the seventh mode. The three rotational and three translational modes can usually be found rather easily. For big models, this preliminary analysis is an additional tool to check the quality of your model. Badly connected parts will appear immediately after the sixth basic rigid body. In general it is hard or maybe impossible to treat models with low quality in the suggested way. (Note: modal analysis is a *mechanical* and not a *numerical* method.)

If the created model is suitable to proceed, the first six eigenfrequencies (very close to zero, all describing rigid body motion) should be checked and then the focus is on the seventh eigenfrequency (clearly nonzero, this is the basic eigenmode of the system). Now the second (and final) eigenmode computation should be started. Specify the number `neigv` of wanted eigenmodes in `*CONTROL_IMPLICIT_EIGEN-VALUE` keyword. Then we set `lflag=1` to separate the six rigid body modes from the structural modes. We choose as separation point `lftend` some frequency between the six and the seventh eigenfrequency, for example half the value of the seventh. After running this analysis the eigenmodes are written to the `d3eigv` file.

The eigenmode basis determined without boundary constraints is now *unique*. In the case of applied boundary constraints the elimination of the rigid body motion of course depends on the boundary constraints. For further analysis with LS-DYNA this is not important at all, but the absence of boundary constraints clearly improves the visibility of the modes and makes it easier to judge their quality and their importance for the expected response. Since all eigenmodes are orthogonal to each other, after removing the first six rigid body modes no *free motion* will be in the eigenmode basis anymore. (Note that in principle it is possible to include free body motion in the eigenvalue database. The setup in LS-DYNA is such that it should be removed automatically. Unfortunately this procedure is not always unique, thus it currently appears better to do it manually.)

Now we are ready to perform the transient modal respectively combined nonlinear analysis with explicit time integration, the central difference scheme. For this we have to go back to the original explicit keyword file of the model. First, for all parts belonging to flexible rigid bodies `*MAT_RIGID` (type 20) must be used. If any flexible rigid body consists of more than one part, it is necessary to choose one of them as a master part and merge the others with `*CONSTRAINED_RIGID_BODIES` keyword. Next, the `*PART_MODES` keyword is used to load the eigenvalue database for each flexible rigid body. In column **pid** we specify the part ID or the master part ID of the flexible rigid body. The parameter **nmfb** defines the number of modes used for the flexible description. Then we set **form**=0 to choose second order accuracy for the flexible body formulation, necessary for large rigid body rotations in one time step. If we do not have large deflections and/or large angular velocities, we can choose **form**=1 for a faster analysis but reducing us to only first order accuracy. Since computational savings with this scheme usually are not very relevant, we do not recommend the latter unless it is really necessary. Computational costs are growing linearly with the number of modes using first order scheme, and quadratically using second order scheme. We select **format**=3 to specify a LS-DYNA eigenvalue database as type of the input file named **filename**.

The treatment of constraints needs special care. In practice, this may be the most cumbersome part of the work as all constraints between parts belonging to the same flexible rigid body have to be removed. Note that this part has been set rigid, and interactions between flexible rigid parts are not allowed to be imposed by constraints. If any constraints were active in the previous eigenvalue analysis, then they will be automatically fulfilled by our modal database.

## Numerical Investigations

### **HEAD IMPACT**

Our first example is the LS-DYNA Model of the Hybrid III 50<sup>th</sup> Free Motion Head Form ([2], see figure 1). It consists of 5935 nodes, 4374 shell, 3028 solid and 12 beam elements. The skin is made out of `*MAT_OGDEN_RUBBER` while other parts are modeled with `*MAT_RIGID`. Our investigation now is focusing on different models of the plate. In a first test the head model is dropped onto a fully elastic plate. The plate consists of 1050 nodes and 480 shell elements. All geometry and material data are taken from [2]. The unit set S3 is used, i.e. basic units are kilogram, millimeter and millisecond. As boundary conditions, we have chosen to put constraints in all three directions on all eight corner nodes of the plate.

Considering now the plate as flexible rigid body – thus as rigid body with superimposed modal analysis, we have to be careful applying the boundary conditions. As mentioned above, a direct incorporation of Dirichlet boundary conditions into the flexible rigid body is not possible. This example illustrates the first of the two possibilities we suggested to avoid this problem. The elements connected with constraints are excluded from the flexible rigid body, see Fig. 3. To obtain good results in the eigenvalue analysis of structures with solid elements we strictly recommend to use the fully integrated S/R solid element (set **elform**=2 in `*SECTION_SOLID` keyword). Figure 3 shows the first three eigenmodes.

For the fully elastic model discretized by solid elements – not looking at locking effects, the computation time with explicit time integration on an AMD Athlon

2200 machine is 244 sec. Using flexible rigid bodies with 2<sup>nd</sup> order update, the computation time is 237 sec for 10 modes, 246 sec for 40 modes and 258 sec for 100 modes. The extra cost for modal analysis is about 8 sec for 100 modes. Note, that the computation with explicit time integration for the head alone without considering the plate and contact time for the same time interval takes 199 sec, while the analysis of the fully flexible plate alone takes only 2 sec. Since the modal method is taken here only for the plate as flexible rigid body, there is essentially little space for reduction of computation time. We will focus on this in more detail in the next example.

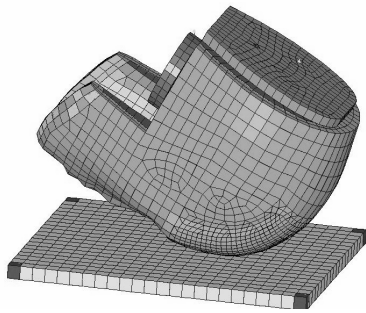

Fig. 1: LS-DYNA Model of the Hybrid III 50<sup>th</sup> Free Motion Head Form

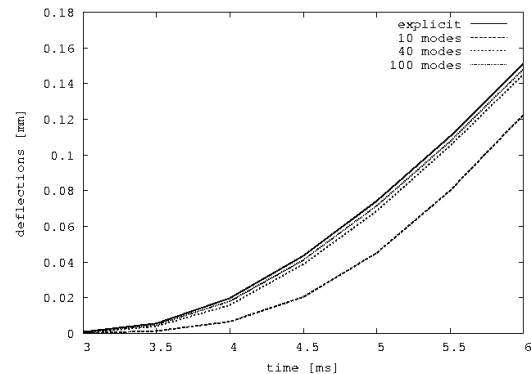

Fig. 2. Comparison of the solution with explicit and modal method; displacements of one node



Fig. 3: First three eigenmodes of the plate

Contact occurs after three milliseconds. Fig. 2 shows the resultant displacements of a typical node on top of the plate in the contact area directly below the head. The solution of the system with explicit time integration is compared with the one obtained using 10, 40 and 100 modes, respectively. The relative error of the maximum displacements compared with explicit time integration is 19.0% with 10 modes, 4.2% with 40 modes and 2.3% with 100 modes for this single quantity.

We have to note that this system is far too small to show the real gain in computation time, but it can be clearly seen that the error using a reasonable but small number of modes remains rather small.

#### **HEAD IMPACT against a SIDE PART**

Our second example is similar to the first, but instead of the plate we use a more realistic part, namely a side part of a car. It consists of 13289 nodes and 12893 shell elements. \*MAT\_PIECEWISE\_LINEAR\_PLASTICITY is used to model the material behavior for the deformable case. In Fig. 4 on the left the side part and on the right the position of the head are shown.

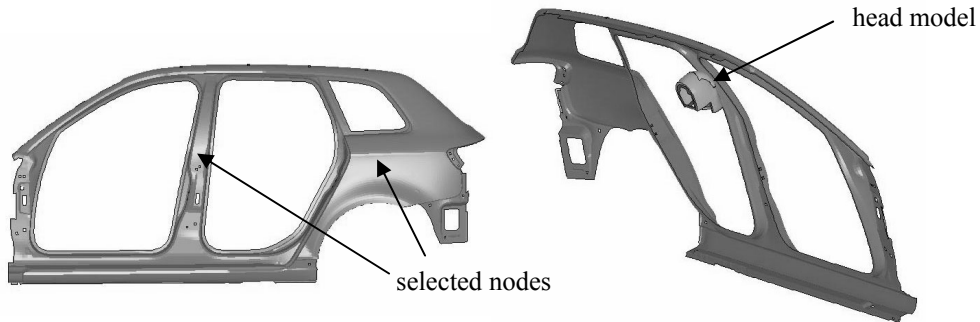

Fig. 4: Side part of a car and position of the head before impact

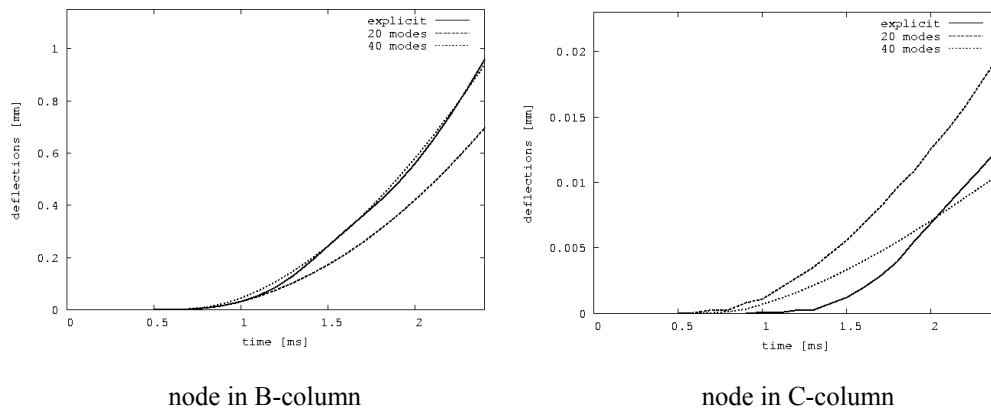

Fig. 5: Deflections of two typical nodes – comparison between explicit and modal solution

The computation time is 1186 sec for explicit time integration of the fully deformable model. Using modal analysis with 2<sup>nd</sup> order update for the rigid body rotations it is 998 sec for 20 modes and 1163 sec for 40 modes. The extra cost for modal analysis is about 78 sec for 40 modes. In this example, the investigation of the side part alone with explicit time integration would cost 383 sec treating it as fully deformable and 87 sec treating it as rigid. Thus, the maximum possible gain using modal methods can be 296 sec. Fig. 5 shows the deflections of two typical nodes, one close to the impact location and the other one far away at the right end. It is clearly visible that the correct answer far away from the impact cannot be achieved with a modal analysis based on a reduced set of modes, as the latter leads to neglecting parts of the wave propagation effects.

### **SHEET METAL FORMING**

As next example we take a very simplified model to find out, if the method can be also used for problems with multiple and different contact conditions. A thin blank discretized with 4719 shell elements, \*MAT\_3-PARAMETER\_BARLAT is pushed by a die (modeled by 5292 solid elements, \*MAT\_ELASTIC) into a matrix, see Fig. 6. Now we want to include some deformations of the die by considering it as flexible rigid body. The counter form on the matrix is intentionally added, to impose a higher deformation on the die at the end of the closure. In this example,

it would be possible, in general, to incorporate the boundary conditions by moving the centre of mass of the flexible rigid body down. Unfortunately this action would change the system slightly compared to the incorporation of Dirichlet boundary conditions on the top of the die and the results would not be easy to compare. Therefore we have chosen the second way and added some solid elements on top and applied the Dirichlet conditions to them.

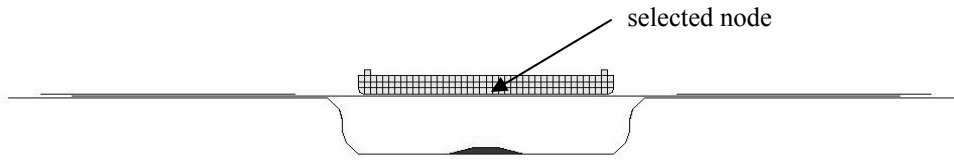

Fig. 6: Simple test example for sheet metal forming.

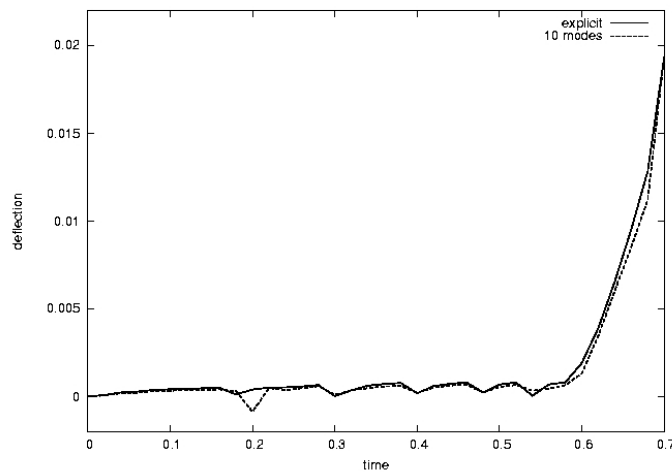

Fig. 7: Comparison of solution with explicit and modal method - displacements of a typical node

For the fully deformable model, the computation time with explicit time integration on an AMD Athlon 2200 machine is 599 min. Using flexible rigid bodies with 1<sup>st</sup> order update for the rigid body rotations, the CPU time is 233 min for 10 modes, 271 min for 20 modes, 298 min for 30 modes, 331 min for 40 modes, 382 min for 50 modes, 408 min for 60 modes and 459 min for 70 modes. Extra costs for modal analysis are about 122 sec for 70 modes.

Fig. 7 shows the deformations of a typical node of the bottom of the die. Since nearly all deformations in this example are dominated by the contact conditions, the modal approximation with 10 modes is already very acceptable. Note that in the case of a rigid die all deformations of the tool would be equal to zero.



### Summary and Conclusions

Modal methods offer the possibility to superimpose linear deformations from a previously computed eigenmode basis onto a rigid body. The method works with high accuracy for models with small numbers of degrees of freedom while becoming an approximate procedure with large numbers of degrees of freedom. Care has to be taken with the treatment of constraints and boundary conditions. Of course, the method works only on the elastic part of the deformable rigid body. The presence of other constraints, e.g. contact conditions, will slow down the overall efficiency in comparison with the examples given in [1].

### References

1. MODAL METHODS FOR TRANSIENT DYNAMICS ANALYSIS IN LS-DYNA. Bradley N. Maker, David J. Benson, Livermore Software Technology Corporation.
2. LS-DYNA MODEL OF THE HYBRID III 50<sup>TH</sup> FREE MOTION HEADFORM USER MANUAL, VERSION 3.4, 2003.
3. LS-DYNA KEYWORD USER'S MANUAL, VERSION 970, LIVERMORE SOFTWARE TECHNOLOGY COOPERATION, APRIL 2003.

