

MODELLING OF AN AUTOMOBILE TYRE USING LS-DYNA3D

W. Hall, R. P. Jones, and J. T. Mottram

School of Engineering, University of Warwick, Coventry, CV4 7AL, UK

ABSTRACT: This paper describes a finite element model used to investigate the quasi-static behaviour of a stationary automobile tyre vertically loaded against a stiff horizontal surface. The model includes a representation of the tyre, a steel wheel and a surface. The tyre is represented in detail by a number of tyre components, the wheel and surface are coarsely modelled. LS-DYNA3D is used to simulate the inflation of the tyre, the fit between the tyre and the wheel and the vertical loading of the tyre against the surface. Simulation results, such as the load-deflection characteristics and the load-tyre/ground contact patch dimensions are compared with mixed success to those obtained experimentally. The stiffness of the tyre components and the inflation pressure are varied independently and the simulation is repeated. The resulting load-tyre/ground contact patch dimensions are discussed in context with the development of a rolling tyre model.

KEY WORDS: LS-DYNA3D, automobile tyre, load-deflection characteristics, load-tyre/ground contact patch dimensions.

1. INTRODUCTION

Automobile tyres are complex structures formed from a number of rubber components and reinforced rubber composites. Due to this complexity and the limitations of traditional implicit Finite Element (FE) packages, accurate prediction of the dynamic behaviour of a rolling tyre, such as the tyre transient responses, has not been feasible [1]. In recent years, however, the reduced computational demand associated with explicit FE packages, such as LS-DYNA3D [2], has made prediction of the dynamic behaviour of a rolling tyre attainable. As a consequence, work in this area has increased. Typically, however, the work has focused on the prediction of the global behaviour of tyres [1, 3, 4]; few investigations have involved the prediction of local behaviour.

The long-term aim of the work is to develop an FE model capable of predicting the dynamic behaviour of a rolling tyre, and in particular, the transient stresses and strains in the tyre local to the tyre/ground contact patch. In this paper, a model has been developed to investigate the quasi-static behaviour of a stationary tyre vertically loaded against a stiff horizontal surface. The technique used to develop the model is described. Simulation results, such as the load-deflection characteristics and the load-tyre/ground contact patch dimensions, obtained using LS-DYNA3D [2] are compared to those obtained experimentally. Finally, model parameters are varied to determine their influence on the contact patch dimensions.

2. AUTOMOBILE TYRE

In the present work, a 195/65 R15 automobile tyre is used; where 195 identifies the section width in millimetres (when mounted on a wheel with 5½ J rim contour), 65 identifies the ratio between the section height and section width (given as a percentage), R indicates a radial tyre and 15 identifies the wheel rim diameter in inches. The tyre has a plain tread with two circumferential grooves. Like all tyres, however, it is constructed from a number of rubber components and reinforced rubber composites. The tread, liner, and each sidewall, apex and clinch are rubber components. The beads and breakers (steel cord embedded in a

rubber matrix), and the plies and bandages (nylon cords embedded in a rubber matrix) are reinforced rubber composites. The cords in the beads and bandages are orientated circumferentially around the tyre. Those of the plies and breakers are orientated at an angle of 90° and $\pm 21^\circ$ to the tyre circumference, respectively. The same tyre is used in experimental work performed by Dennehy *et al* [5] and in a previous FE simulation performed by Hall *et al* [6]. A labelled sketch of the tyre cross-section is shown in Figure 1.

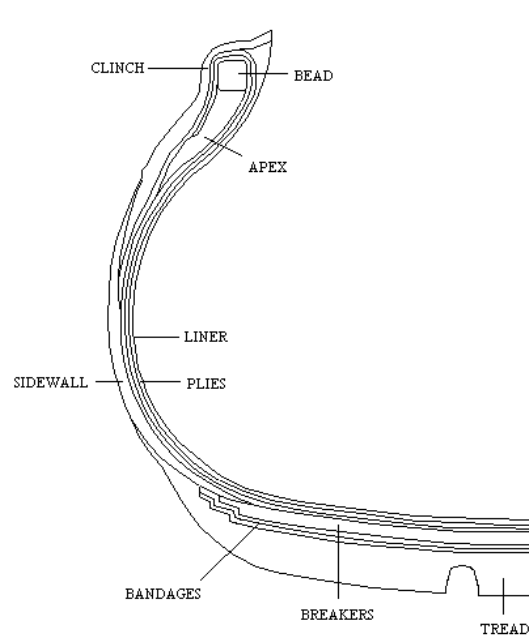

Figure 1. Sketch of tyre cross-section.

3. FINITE ELEMENT MODEL

The FE model was developed using technical data provided by Dunlop Tyres Ltd. It includes a representation of the tyre (described in section 2), a wheel with a $5\frac{1}{2}$ J rim contour and a horizontal surface. The cross-section of the model is shown in Figure 2 and the complete three-dimensional model is shown in Figure 3.

The tyre was modelled in detail as a composite structural material using a total of 56,400 solid and membrane elements. Each of the tyre components (rubber components and reinforced rubber composites) were individually represented. The model was refined local to the tyre/ground contact patch.

The rubber components of the tyre and the beads were modelled as deformable continua using linear (constant stress) solid elements. The plies, bandages and breakers were modelled using ‘discrete reinforcement techniques’; the rubber matrix was modelled as a deformable continuum using linear solid elements and the reinforcement (cords in a thin layer of rubber matrix) was modelled discretely using quadrilateral membrane elements. The interfaces between adjacent components and between the matrix and reinforcement of the plies, bandages and breakers were assumed to be fully bonded (using shared nodes).

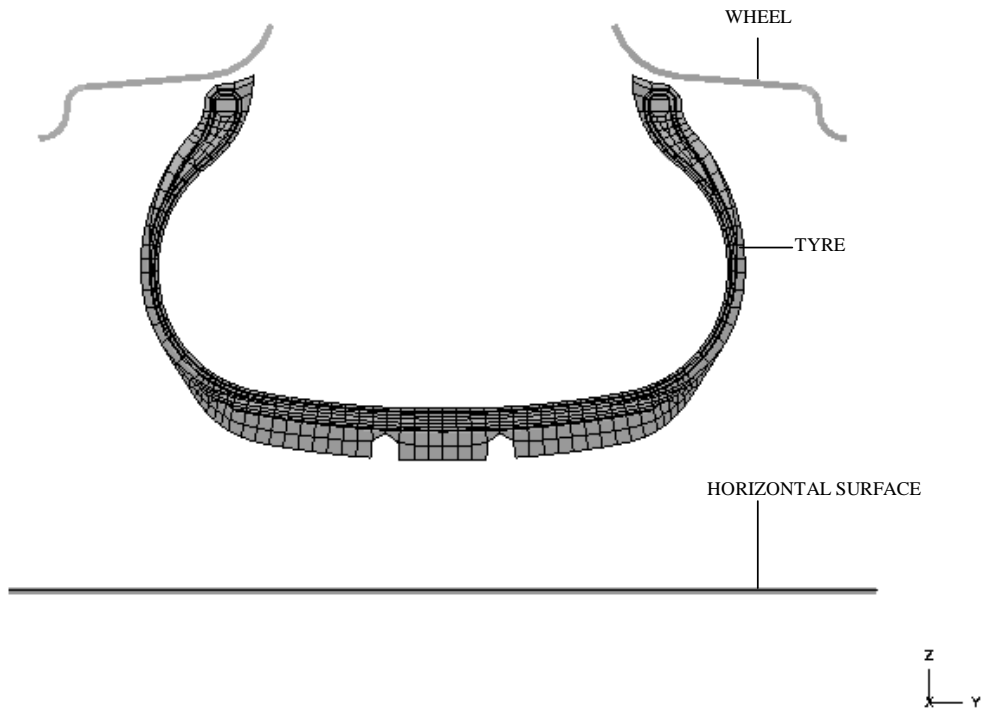

Figure 2. Cross-section of the finite element model.

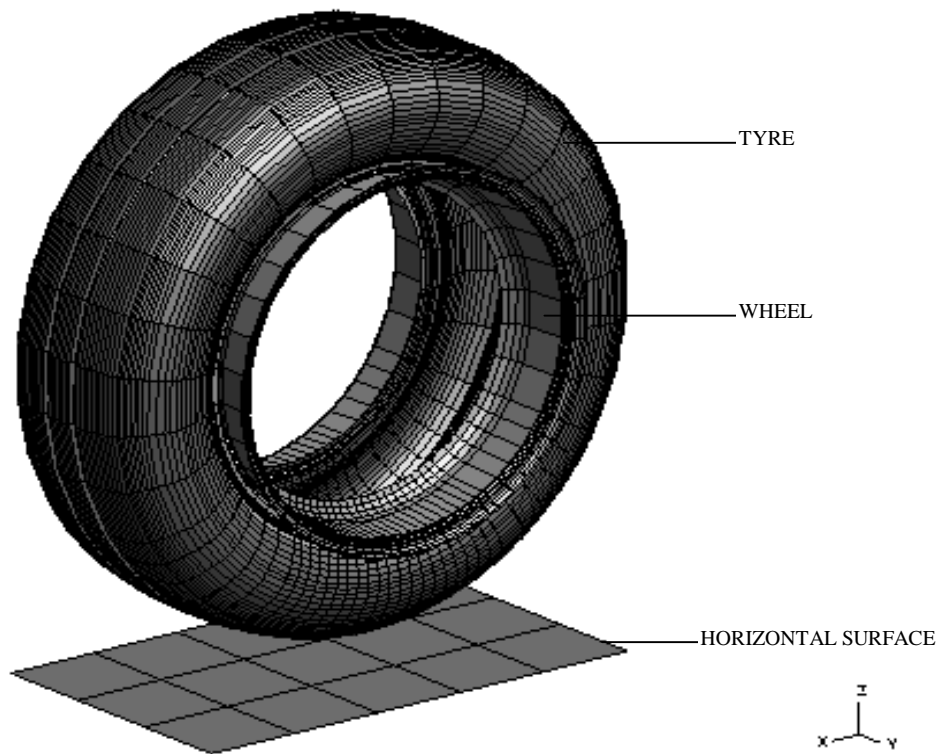

Figure 3. Three-dimensional finite element model.

The elastic constants of each of the rubber components and the rubber matrix of the plies, bandages and breakers, were represented using a hyperelastic (rubber) material model based on the first-order relationship of the strain energy function W , derived by Rivlin [7], viz

$$W = C_{10}(I_1 - 3) + C_{01}(I_2 - 3), \quad (1)$$

where C_{10} and C_{01} are elastic constants related to the material's shear modulus and the independent variables I_1 and I_2 are related to the principal extension ratios λ_1 , λ_2 , and λ_3 , by $I_1 = \lambda_1^2 + \lambda_2^2 + \lambda_3^2$ and $I_2 = 1/\lambda_1^2 + 1/\lambda_2^2 + 1/\lambda_3^2$.

The elastic constants C_{10} and C_{01} were calculated from estimated stress-strain curves using a curve fitting programme developed from Equ. (1). The curve fitting programme was based on the least squares method. For the particular case of simple extension, a comparison between the estimated stress-strain curve for the rubber tread compound, and the corresponding stress-strain curve derived from Equ. (1) is shown in Figure 4.

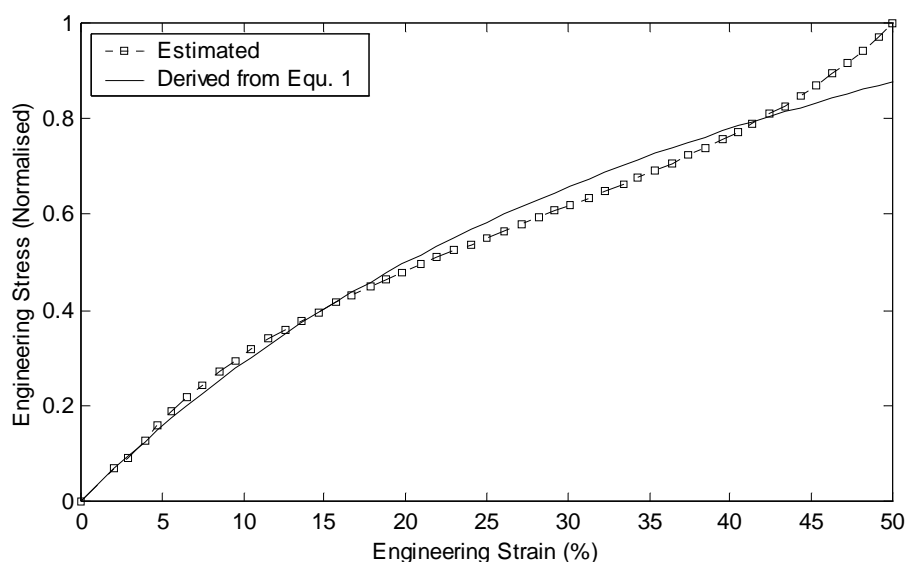

The elastic constants of the reinforcement of the plies, bandages and breakers, were represented using an orthotropic elastic material model. They were calculated using volume fractions and estimated elastic constant data for the constituents, by the Halpin-Tsai micromechanical equations [8] which were originally derived for fibre reinforced plastic composites. Consideration was given to the orientation of the cords in the reinforcement. For simplicity, the elastic constants of the beads were represented using a linear elastic material model. The elastic modulus and Poisson's ratio of the beads were estimated based on those of mild steel.

The steel wheel and horizontal surface were assumed to be rigid. The wheel was modelled in two halves using 1400 quadrilateral shell elements. To allow simulation of the interaction between the tyre and the wheel, the two halves were initially positioned either side of the

tyre. The horizontal surface was coarsely modelled using 15 quadrilateral shell elements and was initially positioned below the tyre.

4. FINITE ELEMENT SIMULATION

In the present work, the inflation of the tyre, the fit between the tyre and the wheel and the vertical loading of the tyre against the horizontal surface were simulated using LS-DYNA3D. The deformation of the cross-section of the FE model during the simulation is shown in Figure 5. Figure 5(a) shows the cross-section at the start of the simulation and Figures 5(b) to 5(d) show the cross-section as the simulation progresses.

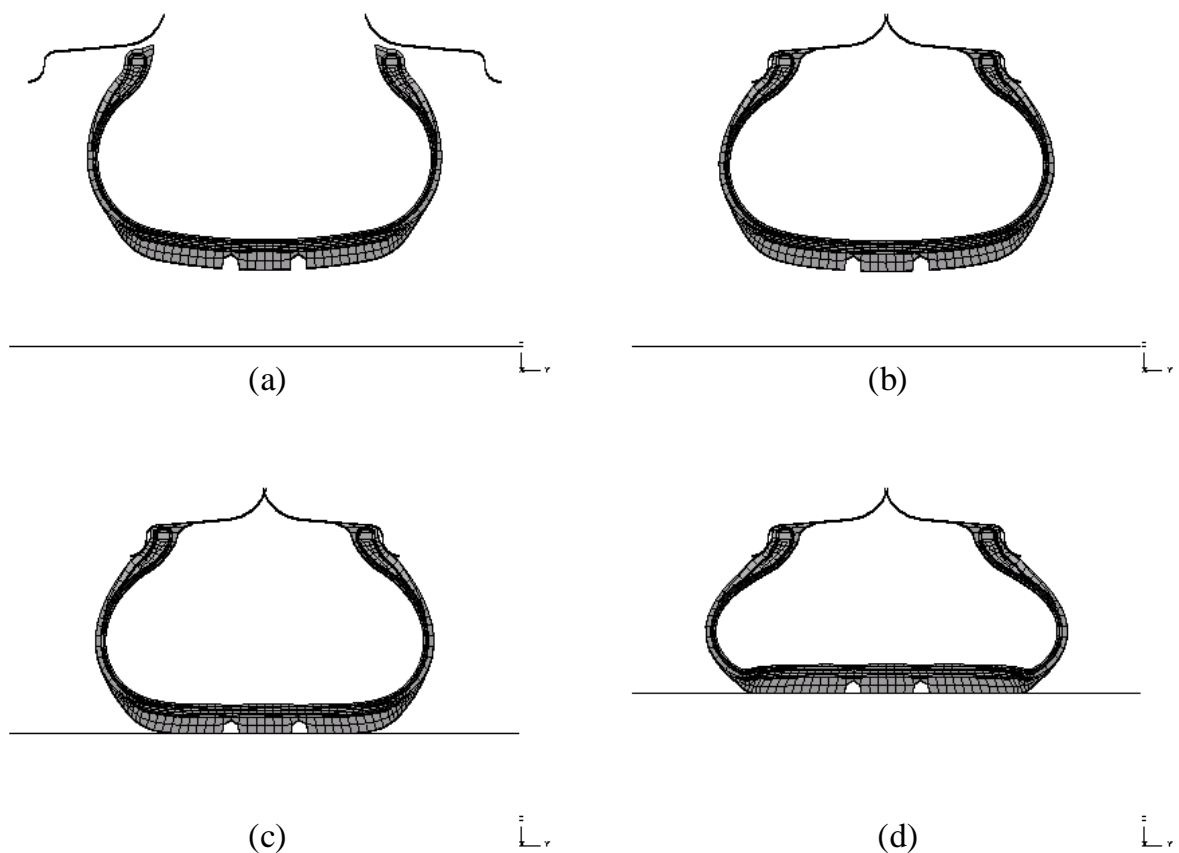

Figure 5. Deformation of the cross-section during the simulation: (a) undeformed ($t = 0.00s$); (b) due to inflation of the tyre and the fit between the tyre and the wheel ($t = 0.03s$); (c) at a vertical load of 1kN ($t = 0.18s$); (d) at a vertical load of 5kN ($t = 0.36s$).

The inflation of the tyre and the fit between the tyre and the wheel were carried out simultaneously over a period of 0.03s. A pressure of 0.2MPa (29psi) was applied normal to the ‘inner face’ of the tyre liner and the two halves of the wheel were displaced laterally (in

the y-direction) until the actual fit between the tyre and wheel was represented. The pressure was assumed to remain constant during the simulation.

After the tyre was allowed to achieve a state of equilibrium, the tyre was vertically loaded. The horizontal surface was displaced vertically (in the z-direction), while the two halves of the wheel were constrained, until a vertical load of approximately 5kN was applied to the tyre. It should be noted that the weight of a typical saloon car is approximately 16kN (4kN per wheel). The vertical loading of the tyre against the horizontal surface was carried out over a period of approximately 0.24s.

To simulate both the contact between the tyre and the wheel and between the tyre and the horizontal surface, surface-to-surface contact interfaces were defined based on the penalty formulation provided in LS-DYNA3D [2]. Between the tyre and the wheel and between the tyre and the horizontal surface, the dynamic (sliding) coefficient of friction were assumed to be 0.1 and 0.7, respectively.

In order to optimise the response of the tyre during the simulation, the tyre components (rubber components and reinforced rubber composites) were critically damped using mass-proportional damping. To prevent hourglassing, i.e. modes of deformation of solid and shell elements having no stiffness, an hourglass control model based on the Flanagan-Belytschko stiffness formulation provided in LS-DYNA3D [2] was employed.

The total simulation was carried out over a period of 0.4s using a 'forced' minimum time increment (for mass scaled solutions) of 0.5×10^{-6} s. The 'forced' minimum time increment results in an increase in model mass of approximately 13% and a computational time of approximately 200h (utilising a Sun Ultra 60, 360MHz workstation). The resulting increase in model mass was judged to not significantly affect the simulation results.

5. RESULTS AND DISCUSSION

To benchmark the performance of the FE simulation, experimental data has been provided by Dunlop Tyres Ltd. The data includes load-deflection and load-tyre/ground contact patch measurements obtained by inflating the tyre (described in section 2) to a pressure of 0.2MPa and vertically loading it against a stiff horizontal surface.

In the simulation, the load was assumed to be the vertical (z-direction) reaction force generated at the tyre/ground contact patch and the deflection was assumed to be the corresponding vertical deflection at the centre of the contact patch. The contact patch dimensions were calculated from the co-ordinates of the nodes on the 'outer face' of the tyre tread. These tyre nodes were assumed to be in contact with the horizontal surface when their vertical co-ordinates corresponded to the vertical co-ordinate of the nodes on the surface. Since linear elements were used in the FE model, it was assumed that the contact patch dimensions remained constant between successive nodal contacts.

Figure 6 shows a comparison between the load-deflection characteristics predicted by the simulation and those obtained experimentally. The simulation results are in excellent agreement with those obtained experimentally. Both indicate an approximately linear relationship between load and deflection; a relationship confirmed by others [9, 10].

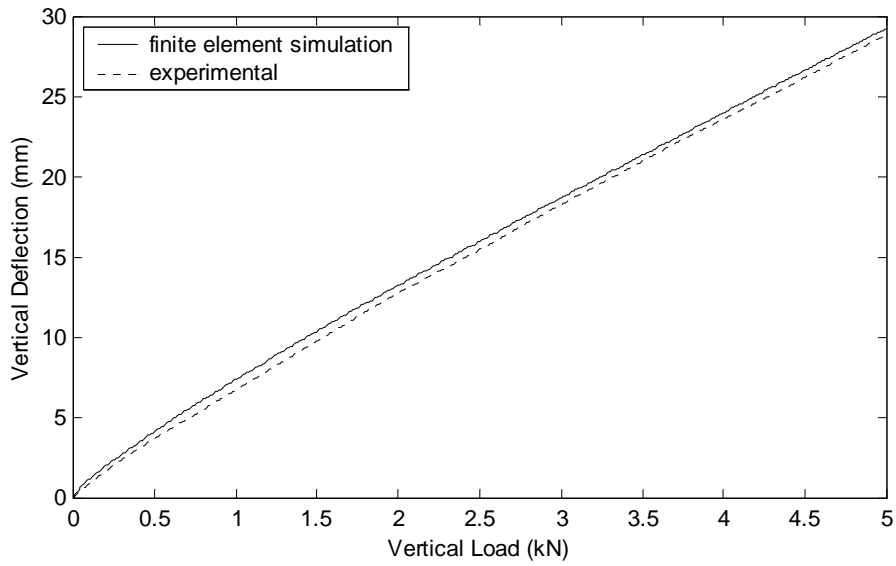

Figure 6. Load-deflection characteristics.

Figures 7 and 8 show a comparison between the load-tyre/ground contact patch dimensions predicted by the simulation and those obtained experimentally. The simulation results and the experimental data both suggest, for loads between 1kN and 5kN, an approximately linear relationship between load and contact patch length, and a non-linear relationship between the load and the contact patch width (the rate of increase of the contact patch width reducing as the load is increased). At the distinct points when nodal contact occurs between the tyre nodes and the horizontal surface, however, the contact patch dimensions predicted by the simulation are typically 25mm larger than those obtained experimentally.

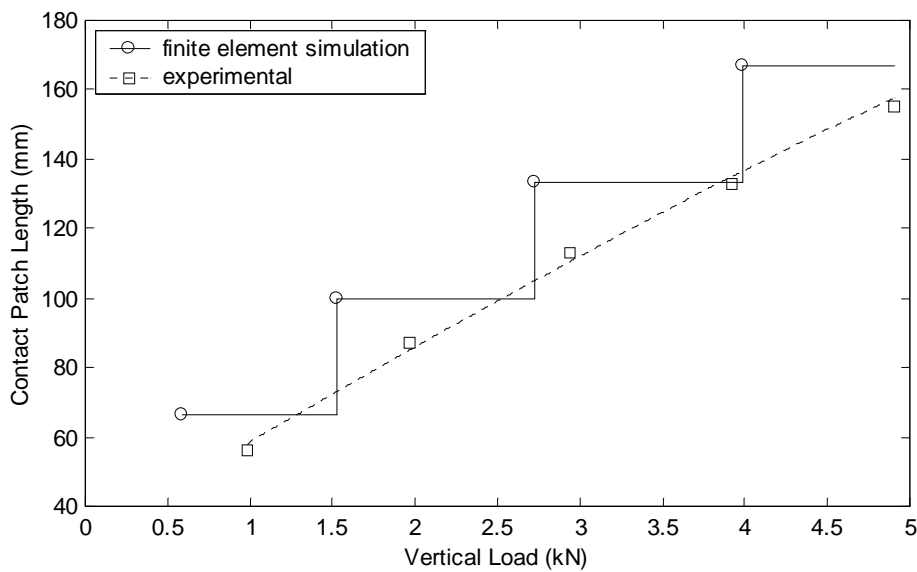

Figure 7. Load-tyre/ground contact patch length.

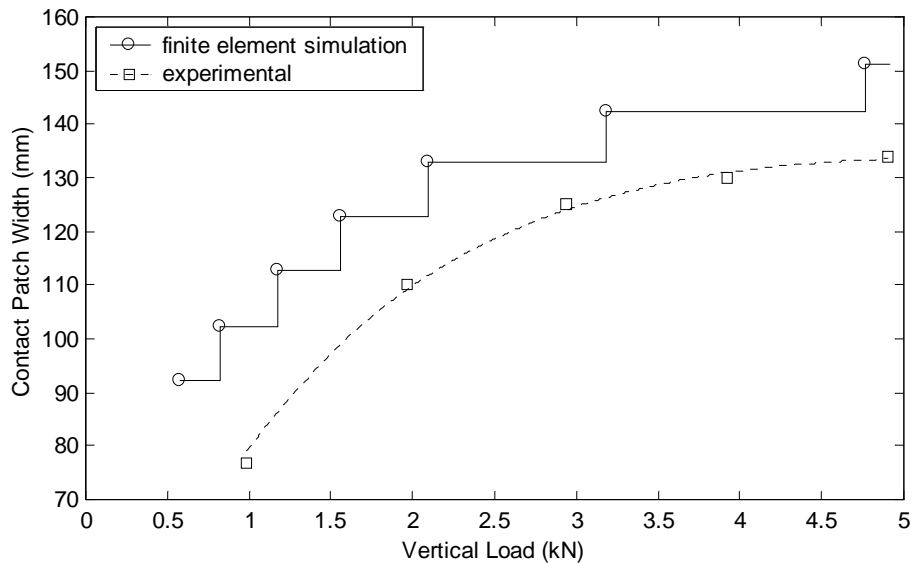

Figure 8. Load-tyre/ground contact patch width.

6. PARAMETRIC STUDY

The authors are currently conducting an extensive parametric study to determine the reason(s) the load-tyre/ground contact patch dimensions (length and width) predicted by the simulation differ from those obtained experimentally. The estimated stiffness of the tyre components, the assumption that the pressure remains constant as the tyre distorts under load, the density of the mesh and the contact algorithm used in the FE model were all identified as possible causes. To date, the simulation has been repeated varying independently the stiffness of the tyre components and the inflation pressure.

By varying the model parameters to observe their influence on the load-tyre/ground contact patch dimensions there is the likelihood that the load-deflection characteristics (see Figure 6) will deviate from those obtained experimentally. To achieve the long-term aim of the work, however, it is considered more important to accurately predict the contact patch dimensions, since this relationship will have a greater influence on the transient stresses and strains local to the tyre/ground contact patch, than the deflection. It is therefore the authors' recommendation that FE tyre models, particularly those used to investigate the behaviour of a rolling tyre, should be benchmarked against the load-tyre/ground contact patch dimensions.

Figures 9 and 10 show the predicted load-tyre/ground contact patch dimensions when the stiffness of the tyre components is varied by $\pm 25\%$; a variation considered to envelop the possible range in the stiffness. Figures 11 and 12 show the predicted load-tyre/ground contact patch dimensions when the inflation pressure is varied by the same percentage.

Varying the stiffness of the tyre components is shown in Figures 9 and 10 to only slightly change the predicted contact patch dimensions. At the distinct points when nodal contact occurs between the tyre nodes and the horizontal surface, even with a 25% increase, the predicted contact patch dimensions remain significantly larger than those obtained

experimentally. Varying the inflation pressure appears to have more significant influence, particularly on the contact patch length. A recent estimate based on the volume change as the tyre distorts under load, however, suggests the increase in pressure is likely to be less than 5% at a load of 5kN (500kg). The influence on the contact patch dimensions is therefore likely to be significantly less than that shown in Figures 11 and 12.

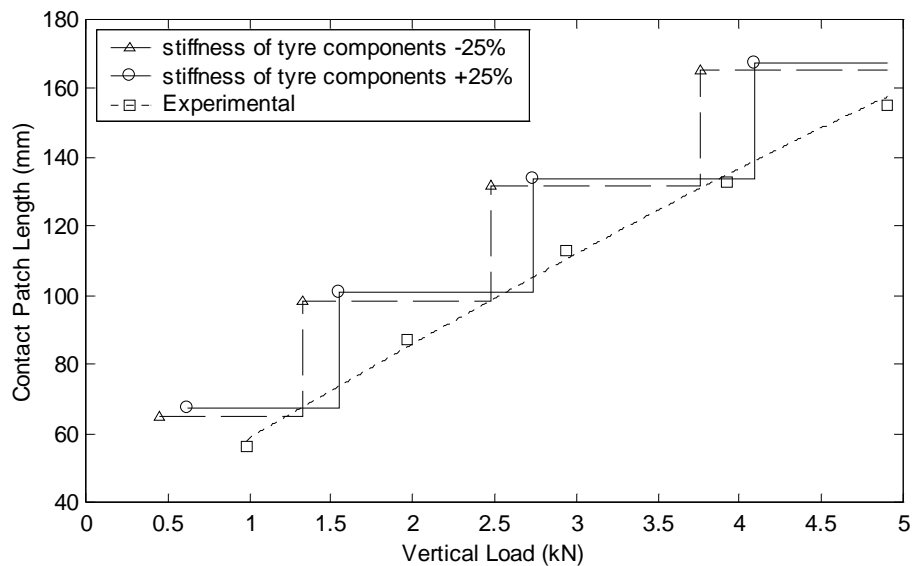

Figure 9. Load-tyre/ground contact patch length.

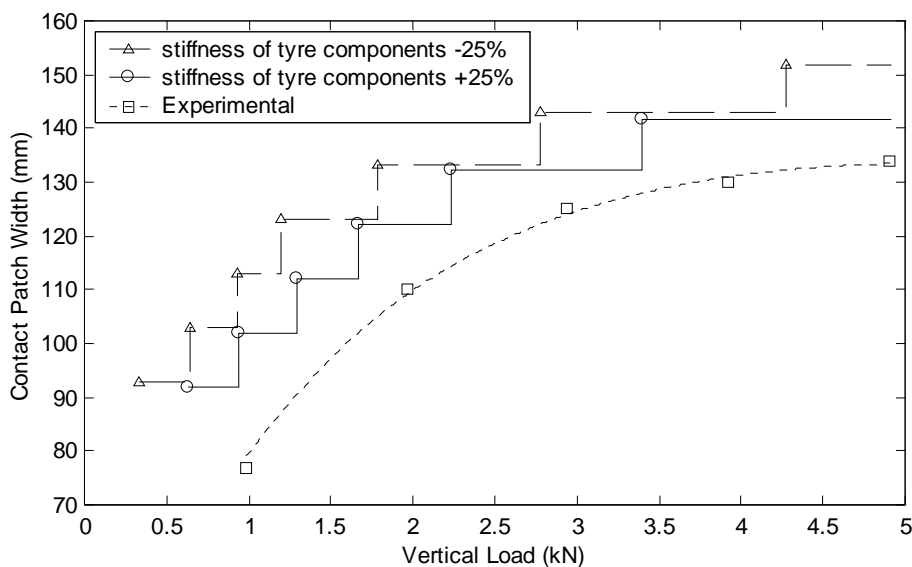

Figure 10. Load-tyre/ground contact patch width.

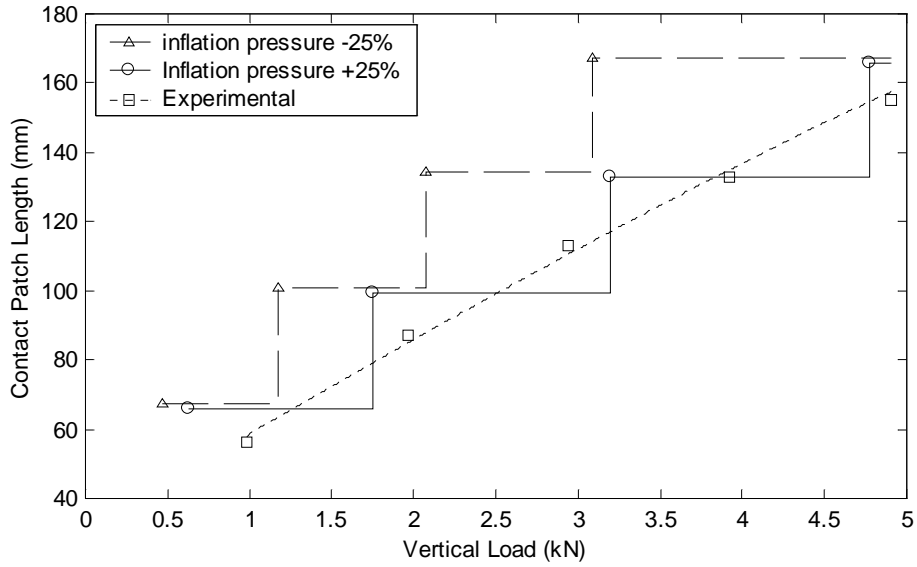

Figure 11. Load-tyre/ground contact patch length.

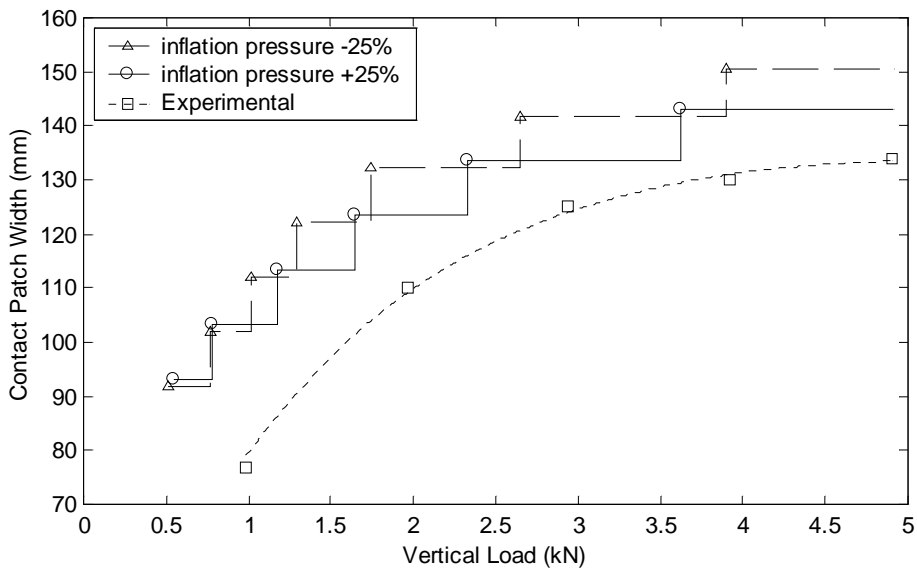

Figure 12. Load-tyre/ground contact patch width.

From the parametric study, it is evident that possible variations in either the stiffness of the tyre components or in the inflation pressure (resulting from volume changes as the tyre distorts under load) cannot explain the reason the load-tyre/ground contact patch dimensions predicted by the simulation differ from those obtained experimentally. It is therefore considered likely that the difference is related to the way LS-DYNA3D is solving the problem. Research is currently focusing on modelling issues such as the density of the mesh or the contact algorithm used in the LS-DYNA3D simulation.

7. CONCLUSIONS

The quasi-static behaviour of a stationary automobile tyre vertically loaded against a horizontal surface was successfully investigated using a three-dimensional FE model. Simulation result obtained using LS-DYNA3D were compared with mixed success to those obtained experimentally. Although an excellent correlation was found between the load-deflection characteristics, the load-tyre/ground contact patch dimensions predicted by the simulation differed from those obtained experimentally. To determine the reason(s) for the difference, the authors are conducting an extensive the parametric study. Early results from a parametric study have indicated that possible variations in either the stiffness of the tyre components or in the inflation pressure (resulting from volume changes as the tyre distorts under load) cannot explain the difference. It is therefore considered likely that the difference is mainly related to modelling issues such as the density of the mesh or the contact algorithm used in the LS-DYNA3D simulation. For the successful development of a rolling tyre model it is considered essential to have accurate contact patch predictions.

ACKNOWLEDGEMENTS

The work reported here was supported in part by an EPSRC research grant GR/M86835.

REFERENCES

1. B. G. Koa and M. Muthukrishnan, 'Tire Transient Analysis with an Explicit Finite Element Program', *Tire Science and Technology*, **25**(4), pp. 230-244
2. J. O. Hallquist, *LS-DYNA3D Theoretical Manual*, Livermore Software Technology Corporation, 1998.
3. M. Koishi, K. Kabe, and M. Shiratori, 'Tire Cornering Simulation Using an Explicit Finite Element Analysis Code', *Tire Science and Technology*, 1998, **26**(2), pp. 109-119.
4. R. Hanley, 'Impact Model', *Tire Technology International 2000*, UK and International Press, pp. 24-28.
5. D. J. Dennehy, R. P. Jones, and K. Hardy, 'Experimental Investigation of Tyre/ground Contact Patch Behaviour of an Automobile Tyre', *IoM International Rubber Conference*, Birmingham, June 2001.
6. W. Hall *et al*, 'Finite Element Simulation of a Vertically Loaded Automobile Tyre', *IoM International Rubber Conference*, Birmingham, June 2001.
7. L. R. G. Treloar, *The Physics of Rubber Elasticity*, 3rd Edition, Oxford University Press, 1975.

8. J. E. Ashton, J. C. Halpin, and P. H. Petit, *Primer on Composite Materials: Analysis*, Technomic Publishing Co., 1969.
9. V. E. Gough, 'Tyres and Air Suspension', *Advances in Automobile Engineering*, G. H. Tidbury Ed., Pergamon Press, 1963.
10. J. R. Ellis, *Vehicle Handling Dynamics*, 1st Edition, Mechanical Engineering Publications Limited, 1994.