

# BatMac: A battery Macro Model to simulate a Full Battery in an Electric or Hybrid Car Crash using LS-DYNA

Pierre L'Eplattenier<sup>1</sup>, İñaki Çaldichoury<sup>1</sup>

<sup>1</sup>Livermore Software Technology Corporation, Livermore, CA, USA

## 1 Introduction

Safety is an important functional requirement in the development of large-format, energy-dense, lithium-ion (Li-ion) batteries used in electrified vehicles. Computer aided engineering (CAE) tools that predict the response of a Li-ion battery pack to various abusive conditions can support analysis during the design phase and reduce the need for physical testing. In particular, simulations of the multiphysics response of external or internal short circuits can lead to optimized system designs for automotive crash scenarios.

Recently, a so called “distributed Randles circuit” model was introduced in LS-DYNA in order to mimic the complex electrochemistry happening in the electrodes and separator of lithium ion batteries [1][2][3]. This model is based on electrical circuits linking the positive and negative current collectors reproducing the voltage jump, internal resistance and dumping effects occurring in the active materials. These circuits are coupled with the Electromagnetics (EM) resistive solver to solve for the potentials and current flow in the current collectors and the rest of the conductors (connectors, busses, and so forth). The EM is coupled with the thermal solver to which the joule heating is sent as an extra heat source, and from which the EM gets back the temperature to adapt the electrical conductivity of the conductors as well as the parameters of the Randles circuits [1]. One of the advantages of the Randles circuit model is the relative easiness to introduce internal short circuits by just replacing the Randles circuits in the affected area by a short resistance [1][3]. The Randles circuit model also is coupled with the mechanical solver of LS-DYNA where the deformations due to a battery crush allow the definition of criteria to initiate internal shorts [1].

The Randles circuit model can be used either on a solid element mesh that include all the layers of a cell [1][2][3], or using composite Tshells [4][5]. In the second case, the mechanics is solved on the composite Tshell, but an underlying solid mesh with all the layers still has to be built to solve the EM and the thermal. This implies very large meshes and hence simulation times when dealing with many cells, let alone modules, packs or a full battery. This new Battery Macro (BatMac) model allows simulating a cell with very few layers of elements (down to one). Two fields exist at each node of the mesh, representing the potential at the positive and negative current collectors. These two fields are connected by a Randles circuit at each node. It still is possible to include external and internal shorts. The internal shorts can be locally created depending on local values of different mechanical, thermal or EM parameters. The Joule Heating generated by the current leaking through the short resistance is sent to the thermal solver.

In this paper, this BatMac model will be presented along with some examples.

## 2 Presentation of the model

### 2.1 General idea

A battery cell is composed of many layers, which can be decomposed as a succession of a few tens of “unit” cell, each composed of a positive current collector, a positive electrode, a separator, a negative electrode and a negative current collector. Figure 1 shows the current flow from one tab to the other through the two current collectors, with the current flowing in one direction in the positive current collector, and in the other one in the negative one.

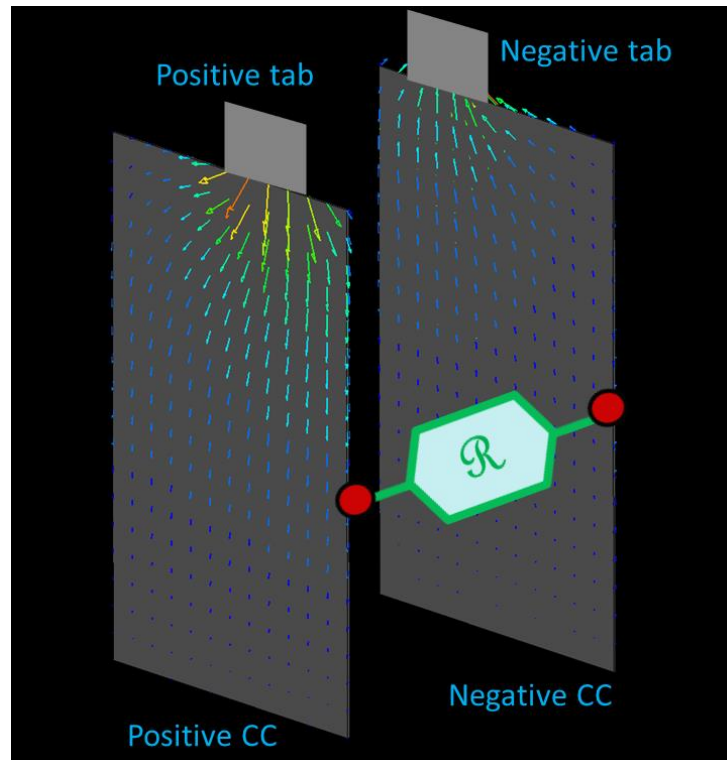

Fig.1: Current flow from the positive tab to the negative tab from the current collectors and the Randles circuits  $\mathcal{R}$  (only 1 represented here).

In the previous “Randles circuit” models [1-5], the electrochemistry happening in the electrodes sandwiched between the two current collectors was replaced by distributed Randles circuits and the current flow in the current collectors was solved by a Finite Element Model (FEM). The succession of layers was still necessary to compute the correct current flow.

In this new BatMac model, instead of having two different parts, one for the positive current collector where the downstream current flows, and one for the negative current collector, where the upstream current flows; the flow of the current is represented on one part only, where two fields co-exist. One field represents the potential on the positive current collector (the gradient of which is the current on the positive current collector), and the other one the potential on the negative one (its gradient being the current on the negative current collector). At each node, these two fields are connected by a local Randles circuit.

In the BatMac model, we even replace all the unit cells of a cell by only one or a few solid layers with the above-mentioned 2 fields at each node. These fields represent the averages of the current flowing respectively on all the positive and negative current collectors of the cell. This is shown on Figure 2.

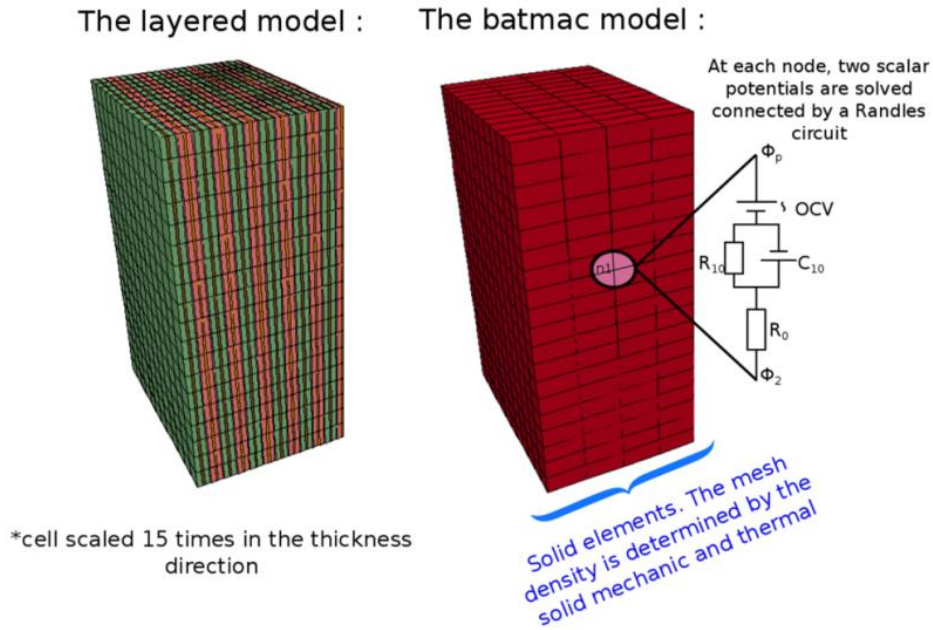

Fig.2: Going from the layered model (left) where all the positive and negative current collectors are meshed to the BatMac model (right) where 2 fields coexist at each node of the mesh, one representing the potential (or current) in the positive current collectors of the cell, and the other one representing the potential (current) on the negative current collectors

## 2.2 Model equations

A schematic of the EM in the BatMac model is shown on Figure 3.

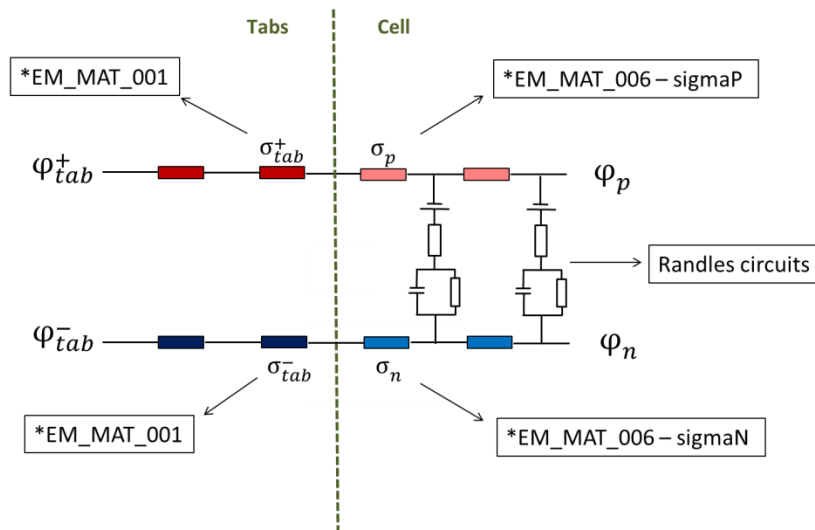

Fig.3: Schematics of the BatMac model.

The equations solved in the BatMac cells are the following:

$$\begin{aligned} \nabla \cdot (\sigma_p \nabla \varphi_p) + \frac{1}{R_0} (\varphi_p - \varphi_n) &= \frac{1}{R_0} (u - v_c) \\ \nabla \cdot (\sigma_n \nabla \varphi_n) - \frac{1}{R_0} (\varphi_p - \varphi_n) &= -\frac{1}{R_0} (u - v_c) \\ \frac{dv_c}{dt} &= \frac{i}{c_{10}} - \frac{v_c}{r_{10} c_{10}} \end{aligned}$$

With the notations of a Randles circuit reminded in Figure 4, and where  $i$  represents the transverse current.

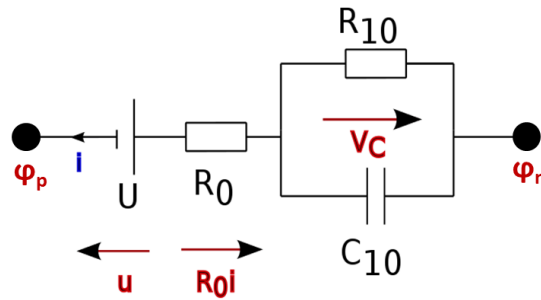

Fig.4: Notations for the components of a Randles circuit

From the potentials  $\varphi_p$  and  $\varphi_n$ , one gets the currents in the positive and negative current collectors respectively by:

$$\begin{aligned} i_p &= \nabla\varphi_p \\ i_n &= \nabla\varphi_n \end{aligned}$$

### 2.3 Thermal solver

The connection of BatMac with the thermal solver works the same way as when using solid elements or Tshells [1], i.e. the Joule heating  $\frac{1}{2}R_0i^2$  generated in the internal resistance  $R_0$  is added to the thermal solver at the node connected to the randles circuit. Conversely, the different parameters of each Randles circuit  $R_0, R_{10}, C_{10}$  can depend on the local temperature at the node.

### 2.4 External and internal shorts in the BatMac model

External shorts can be introduced in the BatMac model exactly the same way as with solid and Tshell battery models [1][4], i.e. it is modeled by replacing some Randles circuits by short resistances. This switch is controlled locally by the values of different mechanical, thermal and EM parameters at the node corresponding to the randles circuit. This is done using a **\*DEFINE\_FUNCTION** which returns the value of the local short resistance, if any. The parameters already available in the define function are node location, pressure, density, von mises stress, electrical conductivity, temperature and effective strain. Other can be added if needed.

## 3 Setting up a BatMac model in LS-DYNA

First of all, a BatMac run requires to turn on the Resistive heating solver in **\*EM\_CONTROL**

**\*EM\_CONTROL**

**emsol**

**3**

A batmac cell or a set of batmac cells is defined by the keyword **\*EM\_RANDLES\_BATMAC**, which is based on a part set Id. The rest of the card is similar to the already existing **\*EM\_RANDLES\_SOLID** for cells defined with solid elements [1] and **\*EM\_RANDLES\_TSHELL** for cells based on composite Tshells [4].

**\*EM\_RANDLES\_BATMAC**

cellId	rdlOrder	AreaType	psid
1	1	1	1

As explained previously, the positive and negative potentials coexist at each node of a BatMac cell. In order to define both the electrical conductivities (and possibly EOS's) of the positive ( $\sigma_p$ ) and negative ( $\sigma_n$ ) current collectors, the keyword `*EM_MAT_006` has been added.

`*EM_MAT_006`

mid	mtype	sigmaP	EosP	sigmaN	eosN
1	5	1.e6		3.e6	

The connection between the BatMac cells and the tabs are done using `*EM_ISOPOTENTIAL` and `*EM_ISOPOTENTIAL_CONNECT` as shown in Figure 5.

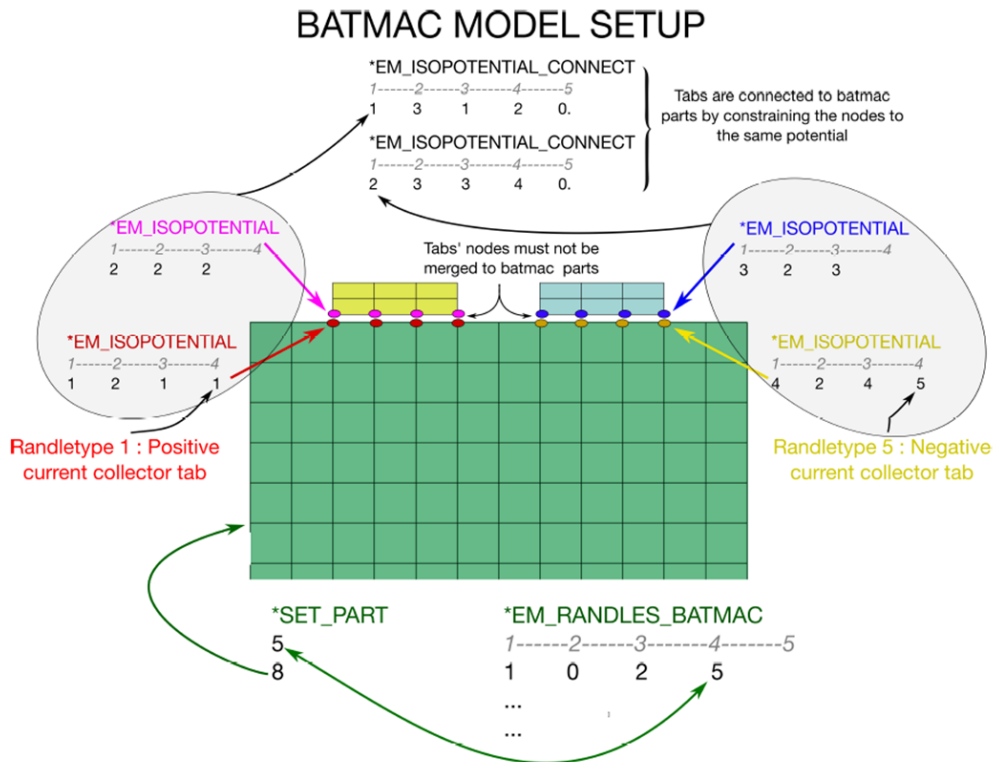

Fig.5: Summary of a BatMac model setup showing in particular the electrical connections between the BatMac parts and the tabs

## 4 Examples

### 4.1 Sphere crash on a 10 cells module

We consider a module composed of 10 adjacent cells mounted in parallel. Each cell is about 20 cm long, 12 cm wide and 3.5 mm thick. The mesh of each cell has 1 element through thickness (to represent the actual 89 layers) and 12x19 in the other directions, thus making a mesh of only 2280 elements, and 5200 nodes, hence 5200 Randles circuits. The case setup is presented on Figure 6.

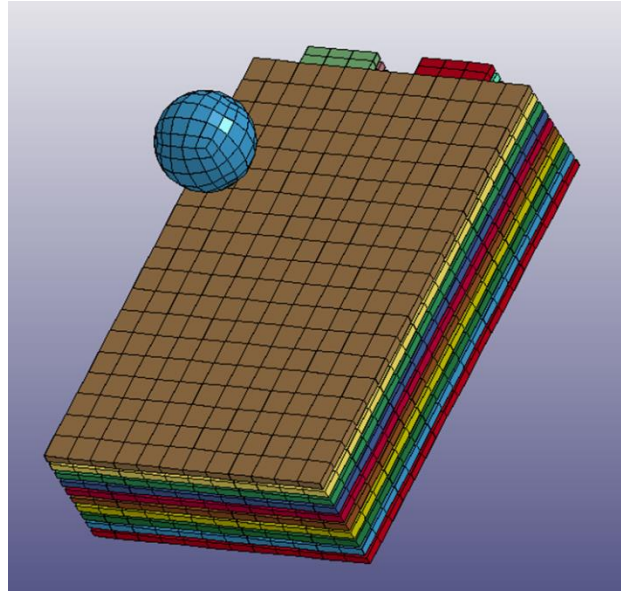

Fig.6: Mesh for the sphere impacting a 10 cells module. The mesh has 3275 solid elements, with 2280 for the cells themselves

This can be compared to the same case using composite Tshells [4] where the underlying mesh used for the EM and the thermal was made of 202,920 elements, and which had 55,440 Randles circuits. This makes the present run about 20 times faster than the same one using composite Tshells. In this case, the onset of internal short was triggered in the `*EM_RANDLES_SHORT` define function by a criteria based on the local pressure. Figure 7, shows the evolution of the internal short.

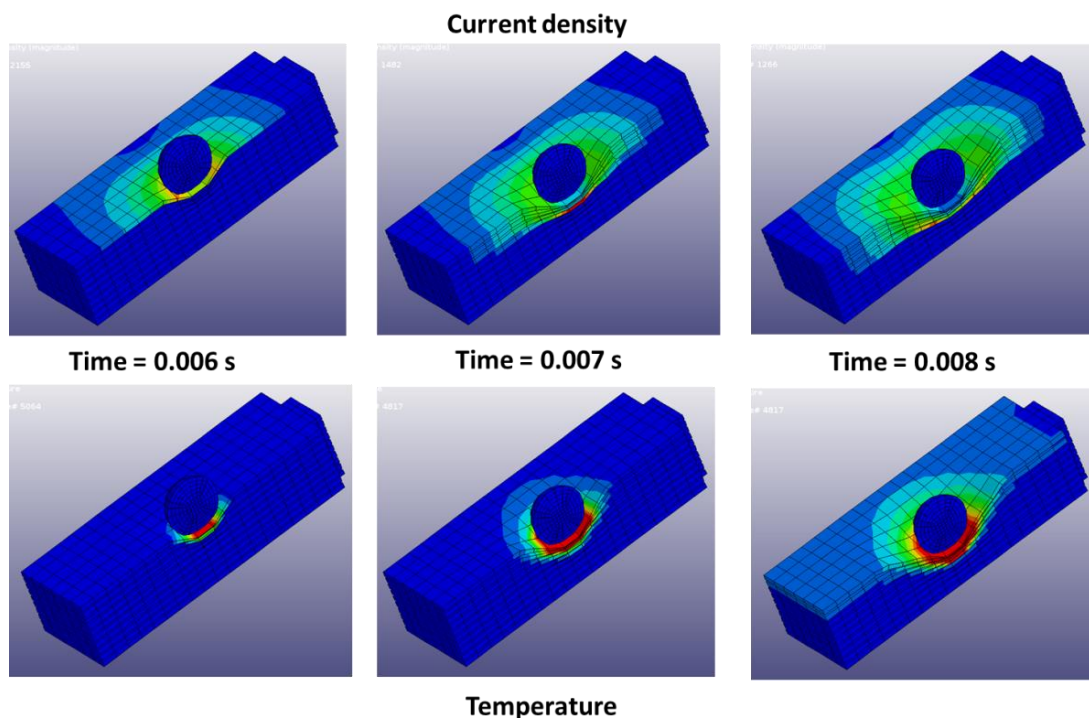

Fig.7: Impact of a sphere on a 10 cells module: current density (top) and temperature (bottom) at different times.

## 4.2 Crush of a 50 cells pack

Since the BatMac model only requires a small number of elements per cells, the next example represents a small pack with 50 cells, crushed by a plane on one of its corner, as shown in Figure 8.

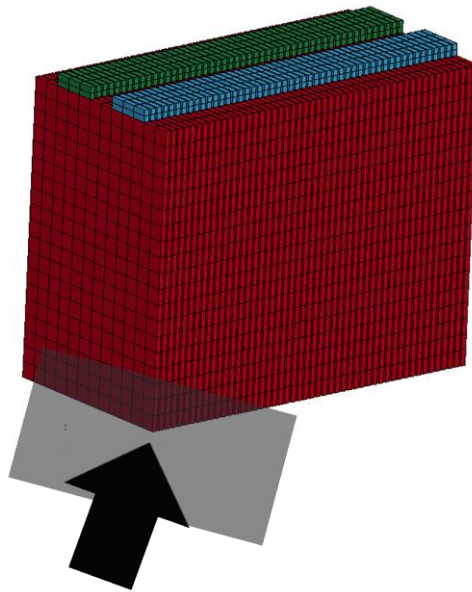

Fig.8: 50 cells pack impacted by a moving plane

The mesh contains about 12,000 elements and ran in about 30 mn on 4 CPU's. The short was triggered by a criteria on the strain at each node. Figure 9 shows the potential, current density and temperature at different time of the impact.

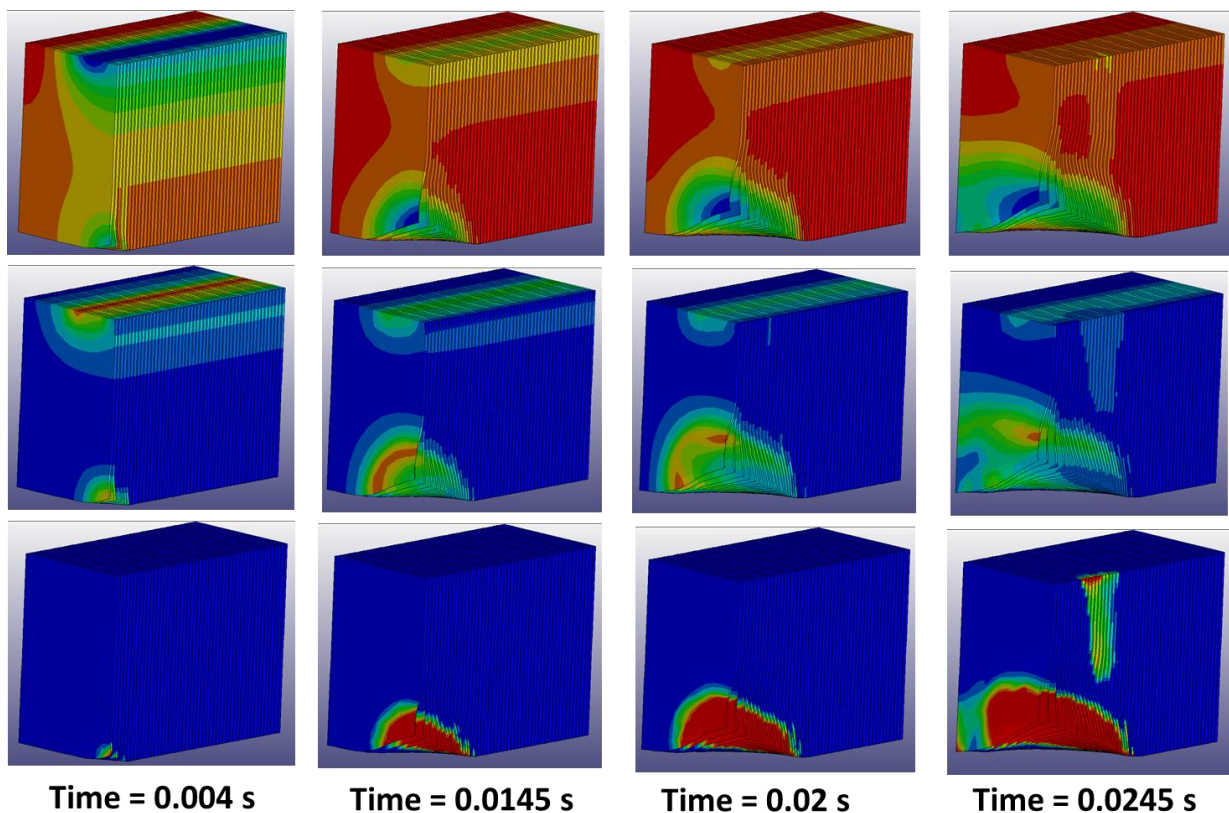

Fig.9: 50 cells pack impacted by a moving plane: potential (top), current density (middle) and temperature (bottom) at different times

## 5 Conclusion

The BatMac model was developed to handle battery modules, packs or even a full battery crush. The goal is to be able to include a full battery in an electric or hybrid vehicle crash. Along with the already existing solid [1-3] and Tshell [4-5] battery models of LS-DYNA, it creates a suite of models for battery crash study, where the user can use the more microscopic models (solid or Tshells) to study the behavior of one or a few cells under abuse conditions, and then use the results of this study on the more macroscopic BatMac model. In particular, the microscopic model should help setup the dependence of the internal short resistance on the different local mechanical, thermal and EM parameters, dependence which then can be used in the **\*DEFINE\_FUNCTION** of the **\*EM\_RANDLE\_SHORT** card of the BatMac model. Table 1 shows a summary of the different battery models in LS-DYNA along with their respective uses.

	<b>Solid</b>	<b>Composite Tshells</b>	<b>Macro model</b>	<b>Meshless</b>
Cell geometry (pouch/cyl/prism)	√/√/√	√/√/√	√/√/√	X
Cell (detailed study)	√	√	X	X
Module	If small	√	√	√
Pack – battery	X	X	√	√
Connection to external circuit	√	√	√	√
Internal short	√	√	√	X
External short	√	√	√	√
Thermal (Joule heating)	√	√	√ (average)	X
Mechanics (Deformations)	√	√	√ (average)	X
LS-prepost Battery packaging	√ (pouch)	Soon	√ (pouch)	X

Table 1: Battery models in LS-DYNA with their different capabilities and usage

## 6 References

- [1] P. L'Eplattenier, I. Caldichoury, J. Marcicki, A. Bartlett, X. Yang, V. Mejia, M. Zhu, Y. Chen, "A distributed Randles circuit model for battery abuse simulations using LS-DYNA", Proceeding of the 14<sup>th</sup> International LS-DYNA User Conference, 2016.
- [2] J. Marcicki, A. Bartlett, X. Yang, V. Mejia, M. Zhu, Y. Chen, P. L'Eplattenier, I. Caldichoury, "Battery abuse case study analysis using LS-DYNA", Proceeding of the 14<sup>th</sup> International LS-DYNA User Conference, 2016.
- [3] J. Marcicki, M. Zhu, A. Bartlett, X. Yang, Y. Chen, T. Miller, P. L'Eplattenier, I. Caldichoury, "A simulation framework for battery cell impact safety modeling using LS-DYNA", Journal of The Electrochemical Society, 164 (2017) A6440-A6448.
- [4] P. L'Eplattenier, S. Bateau-Meyer, I. Caldichoury, "Battery abuse simulations using LS-DYNA", Proceeding of the 11<sup>th</sup> European LS-DYNA User Conference, 2017.
- [5] J. Deng, C. Bae, T. Miller, P. L'Eplattenier, S. Bateau-Meyer „Accelerate Battery Safety Simulations Using Composite Tshell Elements" *Journal of the Electrochemical Society* 2018 165(13): A3067-A3076.