

Design and Testing of an Easy to Use Pinned-down Temporary Concrete Barrier with Limited Deflections

Nauman M. Sheikh and Roger P. Bligh
Texas Transportation Institute
Texas A&M University System, MS 3135
College Station, TX 77843-3135, USA
(nauman@tamu.edu)

Abstract

In work zones where the space available for placing a temporary concrete barrier is very limited, for example bridge replacement projects, the barrier must be strictly restrained to prevent lateral deflection due to vehicular impact. Among the few restraining or anchoring mechanisms currently available, most designs require through the deck bolting, anchor bolts, or other constraining straps. Such mechanisms are difficult to install, inspect, and remove and can result in damage to thin bridge decks.

In this research, a new restrained F-shaped temporary concrete barrier was developed that is easy to install, inspect, and remove, and minimizes damage to the bridge deck or concrete pavements. The mechanism uses a pinned-down approach to restrain the barrier. Steel pins are simply dropped into inclined holes that start from the toe of the barrier and continue short distance into the bridge deck or concrete pavement. The pinned down anchorage design was developed through extensive use finite element analysis. The performance of the final design was evaluated by conducting a full-scale vehicle impact crash test.

The pinned down barrier successfully passed the National Cooperative Research Program Report 350 Test Level 3 requirements. The maximum permanent and dynamic barrier deflections were 5.76 inches (146.3 mm) and 11.52 inches (292.6 mm), respectively.

Introduction

Temporary concrete barriers are commonly used in construction work zones for a number of reasons. These include shielding the motoring public from extreme drop-offs such as in the case of bridge construction and expansion projects, or to prevent the traffic from entering work zone areas where it can potentially impact construction personnel or equipment. Temporary barriers also serve the purpose of preventing the construction machinery or personnel from extreme drop-offs or entering any adjacent traffic lanes. In some situations, temporary concrete barriers are used to separate two-way traffic.

When installing a temporary concrete barrier, certain amount of space must be provided behind the barrier. This space allows for some lateral deflection of the barrier in the event of an impact from an errant vehicle. Due to limited space available in many construction zones, barriers are sometimes restrained using techniques such as anchoring, pinning, or bolting to the bridge deck or pavement to further limit any lateral barrier movement.

Whenever it is necessary to use a restrained temporary concrete barrier due to limited space considerations, a design that is easy to install, results in minimal damage to thin bridge decks or pavements, and is easy to remove or relocate is desired. Since the tying-down mechanism is critical to the safety of the motorists and construction personnel, it is also important that the design be easy to inspect for proper installation.

There are few restrained temporary concrete barrier designs that have been crash tested to provide limited deflection requirements.⁽¹⁾⁽²⁾⁽³⁾⁽⁴⁾ Among the restraining or anchoring mechanisms currently available, most designs require through the deck bolting, anchor bolts, or other constraining straps, which complicate installation, removal, and inspection of the barrier installation.

Research Objective and Scope

The primary objective of this research was to develop a limited deflection restrained concrete barrier that meets National Cooperative Research Program (NCHRP) Report 350 Test Level 3⁽⁵⁾ requirements and limits dynamic deflection to accommodate restricted space requirements in a work zone. The barrier was required to have a safety shape profile ('F' or New Jersey) and a segment length between 12.5 and 15 feet (3.81 and 4.57 meters). It was also required that the barrier be easy to install and cause minimal damage to bridge decks.

This research was performed under the pooled-fund program between the state transportation agencies of Alaska, California, Louisiana, Minnesota, Tennessee, Texas, Washington, and the Federal Highway Administration (FHWA). The participating states initially desired to have a restraint design that works in conjunction with the portable concrete barrier (PCB) designs being used by most of the participating states. If however such a design could not be achieved, the states were open to developing a new restrained barrier design, which did not necessarily incorporate all of the existing state PCB designs.

Evaluation of Existing State Barriers

Since many variations existed between state barrier designs, the researchers suggested developing the restraining mechanism for the barrier design that was expected to result in the largest lateral deflection and vehicular instability. It was argued that the restraint mechanism that performs successfully for this design was expected to perform adequately for other less critical designs as well. An evaluation of the existing barrier designs of the participating states was conducted and it was determined that Washington State Department of Transportation's (DOT) 12.5 ft (3.81 m) New Jersey profile barrier was the most critical design in terms of potential for large barrier deflection due to vehicle impact.⁽⁶⁾ This design was thus initially selected for development of the restrained system.

Pinned-Down Design for NJ Barrier

Based on the review of previously developed designs for restraining temporary concrete barriers to bridge decks and pavements, the researchers adopted the pinned-down approach rather than the bolted-down approach. In this restraint technique, steel pins are inserted into the barrier through inclined holes that are either drilled or cast into the barrier.⁽¹⁾ Once the barrier

segments are placed on site, a drill machine is used to continue the holes a certain distance into the underlying bridge deck or pavement. Thus the steel pins (referred to as the ‘drop-pins’ in this paper) are dropped into the inclined hole, passing through the barrier and a certain distance into the bridge deck or pavement. This approach has many inherent advantages such as the ease of installation, inspection, and removal, and the elimination of through the deck bolting.

In the pinned-down barrier design, it is important that the drop-pins pass over at least one longitudinal rebar inside the barrier. This ensures that if concrete in the vicinity of a pin fails and spalls off during vehicular impact, the rebar will engage the drop-pin and provide additional restraint against lateral barrier movement. The distance between the drop-pin and the longitudinal rebar should therefore be such that ensures proper engagement.

On evaluating barrier cross-sections and reinforcement details of concrete barrier designs of all participating states, it was determined that using a drop-pin angle of 55° from the horizontal will incorporate most of the existing designs, such that no modification will be needed to the barrier reinforcement details. Using this drop-pin angle will ensure that the drop-pins pass over at least one longitudinal rebar inside the barrier. Thus to incorporate existing reinforcement details of the participating states, a drop-pin orientation of 55° was selected. The initial configuration incorporated two drop-pins per barrier segment, located 22 inches (558.8 mm) from each edge of the barrier. The diameter of the drop-pins was 1.5 inches (38.1 mm) and embedment depth of the pins inside the concrete ground was 6 inches when measured vertically.

To evaluate the drop-pin configuration for the free standing WSDOT NJ barrier, a full-scale finite element (FE) model of the barrier was developed. The simulations were performed using the FE analysis program LS-DYNA.

The FE mesh for the barrier model was comprised of solid elements with density of concrete. Most of the elements were assigned rigid material properties while the ends of the barriers were assigned elastic material properties. A friction coefficient of 0.4, as determined from barrier pull tests on a concrete pavement, was used between the barrier and the ground. The ground surface was modeled using rigid shell elements. Regions where the drop-pins were to pass through the ground surface were modeled using solid element blocks. The elements in these blocks were modeled using elastic material representation with properties of the concrete in compression. Thus a complete concrete deck was not modeled to reduce model size. The drop-pins were assigned material properties of ASTM A36 steel. The diameter of the drop-pins and the holes were 1.5 inches (38.1 mm) and 1.75 inches (44.45), respectively.

The full system model of the WSDOT pinned barrier is shown in Figure 1a. The simulation replicated Test Designation 3-11 of NCHRP Report 350. This test involves a 4,409 lb (2,000 kg) pickup truck impacting the barrier at a speed of 62.2 mph (100 km/h) and an angle of 25°. A total of eight barrier segments were modeled to provide a barrier length of 100 ft (30.48 m). The vehicle model impacted the barrier system four feet upstream of the joint between the 3rd and the 4th barrier segment as shown in figure 1a. The vehicle model used in all of the simulations was developed by the National Crash Analysis Center with further modifications from researchers at Texas Transportation Institute.

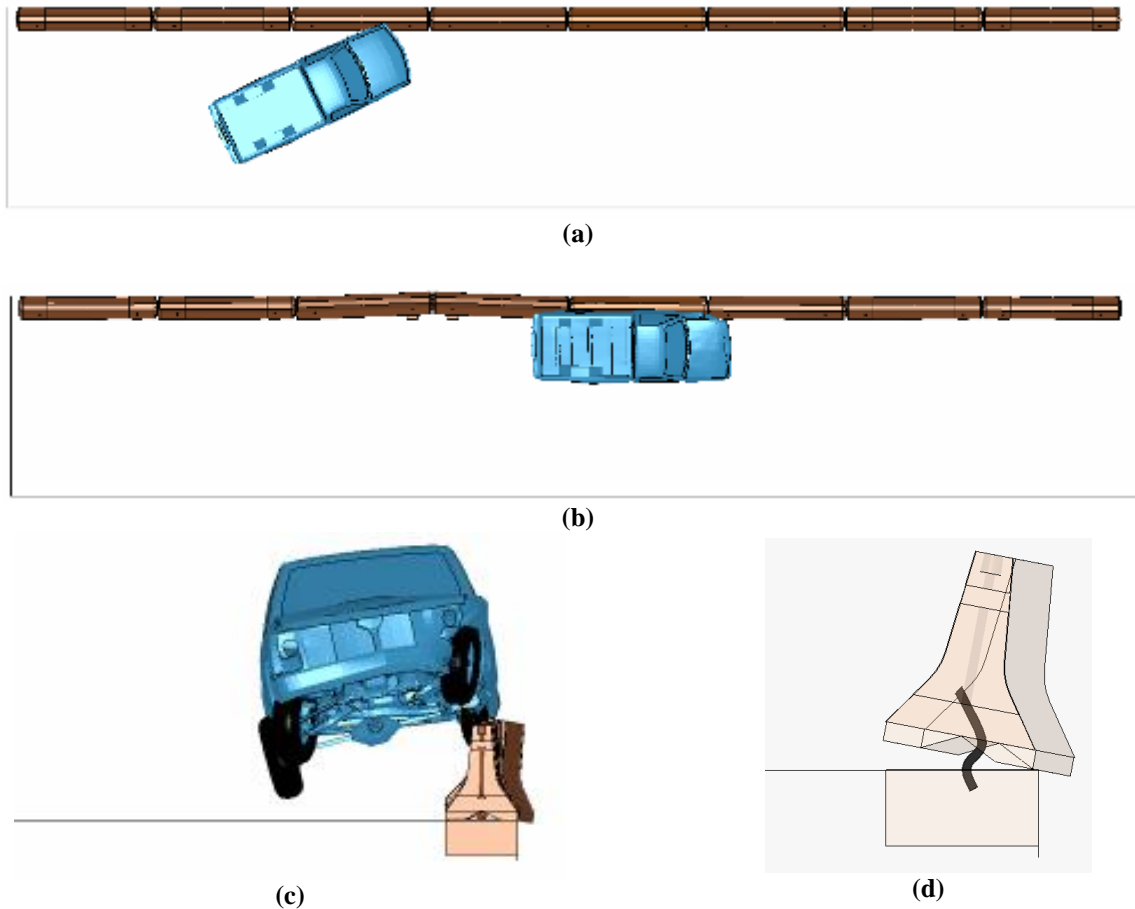

Figure 1 Results of simulation analysis of initial WSDOT pinned-down barrier.

Simulation results indicated that the vehicle was redirected after impact and was expected to stay upright after redirection (Figure 1b). However, the vehicle exhibited significant climb during redirection and the impacted barrier segment showed significant roll due to the impact (Figure 1c and 1d). The high climb of the vehicle can be partially attributed to the NJ profile of the barriers, but it was also attributed to the approximately 15° of roll induced in the barriers during impact. The overall lateral deflection of the barriers was 7 inches.

To save computational time during iterative design simulations, the model did not incorporate concrete failure and thus simulation results were considered lower bound estimates of vehicle stability and barrier performance. The amount of vehicle climb and barrier roll was expected to increase in the test if the concrete around the drop-pins or the barrier faces were to spall off or fail. Based on these considerations, it was concluded that the results of the simulation did not indicate a definite pass and were therefore termed marginal. However, since this configuration offered the most flexibility in applying the drop-pin design to barriers used by all participating states, the states decided to proceed with a full-scale crash test. If the results of the test were successful, the design could be used by all participating states. If, however, the test was to be unsuccessful, further analysis would be conducted to develop a pinned-down barrier which meets the design criteria, but does not necessarily adapt to all existing state barrier designs.

A crash test with the WSDOT 12.5-foot (3.81 m) barrier segments was subsequently performed with the above mentioned pinned configuration, but it failed to meet the NCHRP Report 350 Test Designation 3-11 criteria (see Figure 2). The vehicle exhibited significant climb of the barrier as concrete around one of the drop-pins failed catastrophically (Figure 2b). The drop-pin initially caught on the longitudinal rebar, but slipped off after bending the pin-cap, which then resulted in high barrier roll and vehicle climb. The barrier segment then dropped off the edge of the deck and as it rotated, it caused more rotation and lift in the adjacent upstream barriers, which also eventually dropped off the deck.⁽⁶⁾

Even though the concrete damage at the ends of adjacent barrier segments was moderate, it was enough to reveal some portions of the wire-rope loops that ran into the barrier. Since the wire-rope loops do not have any significant torsional stiffness of their own, once exposed, they resulted in additional rotation of the barrier segments relative to each other. It was therefore noted that the new design should incorporate connections with loops made of round stock steel.

It was also observed that once the barriers started to roll, the drop-pins pulled out of the concrete pavement without significant resistance. Reducing the drop-pin angle relative to the ground was expected to offer more resistance to the drop-pin pullout.

Welding a thicker pin cap to the top of the drop-pins was also expected to help grab on to the longitudinal rebar in case of concrete failure in the vicinity of the drop-pins. It was also noted that further FE analysis of the barrier design should incorporate concrete material failure as it can significantly affect the outcome of the crash test.

Once the evaluation of the crash test results was completed, further analysis was performed to complete the pinned barrier design by modifying design parameters such as the pin angle, barrier profile, barrier connection, etc, as discussed above. The analysis was performed in two steps. In the first step, the existing model of the WSDOT pinned barrier was modified to better capture the failure behavior observed in the test. In the second step, the analysis was performed for the new pinned-down barrier design using modeling techniques incorporated in the modified WSDOT pinned barrier model. Details of these analyses are presented next.



(a)



(b)

Figure 2 Crash test results with the WSDOT pinned barrier.

Modifications were made to capture some of the concrete failure that was observed in the test. The failure was incorporated using the Continuous Surface Cap Model (CSCM)

(MAT_CSCM) in LS-DYNA material library. Inclusion of the concrete failure significantly increases the size of the model and the computational time required to complete the simulations. To reduce model size, concrete failure was only incorporated in regions that exhibited failure in the crash test. These regions are highlighted in Figure 3a. The reinforcement of the barrier was also modeled in these regions using beam elements as shown in Figure 3b. The reinforcement beam elements were tied to the CSCM concrete solid elements using the `CONSTRAINED_LAGRANGE_IN_SOLID` constraint in LS-DYNA.

In the modified WSDOT barrier model, the wire-rope loops were comprised of beam elements that passed a certain distance inside the regions of the barrier where concrete material failure was incorporated (see Figure 3b). This was done to account for barrier rotation resulting from wire-rope loops that were exposed once the concrete failed in their vicinity. The modified full system model of the WSDOT pinned barrier is shown in Figure 3c.

With the inclusion of concrete material failure at barrier faces and by modifying the wire-rope connection details, the relative rotation between adjacent barrier segments was improved compared to the previous model (see Figure 4a). In the crash test, the barriers upstream of the impact point showed a tendency to lift up without much resistance from the pins. This tendency was captured in the modified model as shown in Figure 4b. Similarly, the vehicle had significant climb in the test. The modified model showed an increased climb of the vehicle compared to the previous model, as shown in Figure 4c.

While significant improvements were made to the FE model of the WSDOT pinned barrier, a complete agreement with crash test results was not achieved within the limited resources allocated for the effort. The simulation results showed some failure in the concrete region around the drop-pin, but the catastrophic failure observed in the test was not replicated. This, in turn, influenced the degree of barrier roll and vehicle climb. Nonetheless, the overall model behavior was significantly improved and provided higher confidence in the use of simulation for analysis of the new pinned-down barrier system.

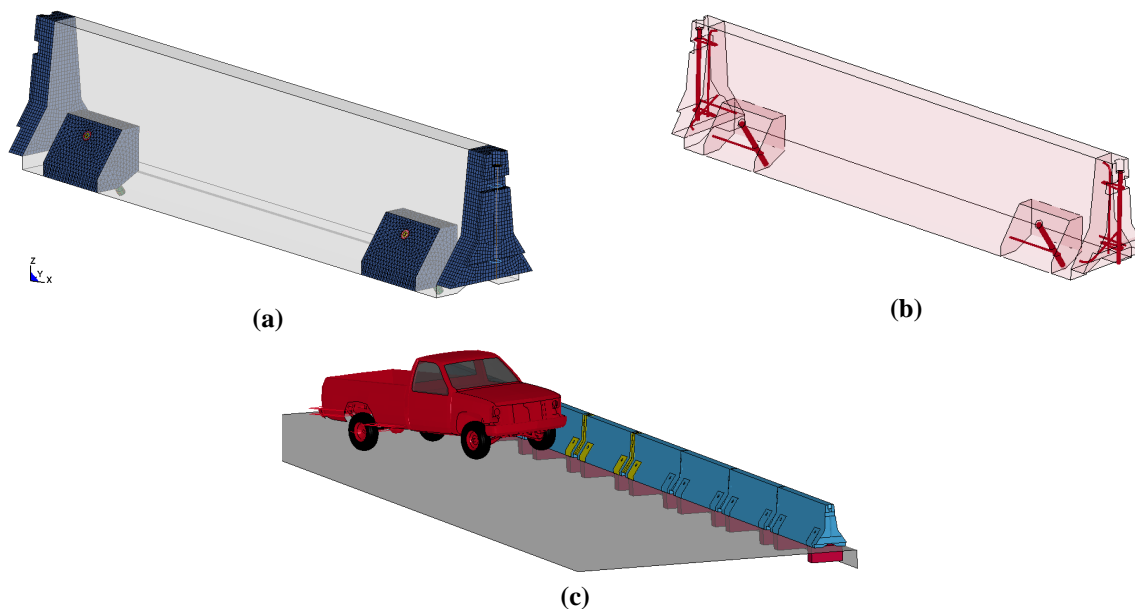
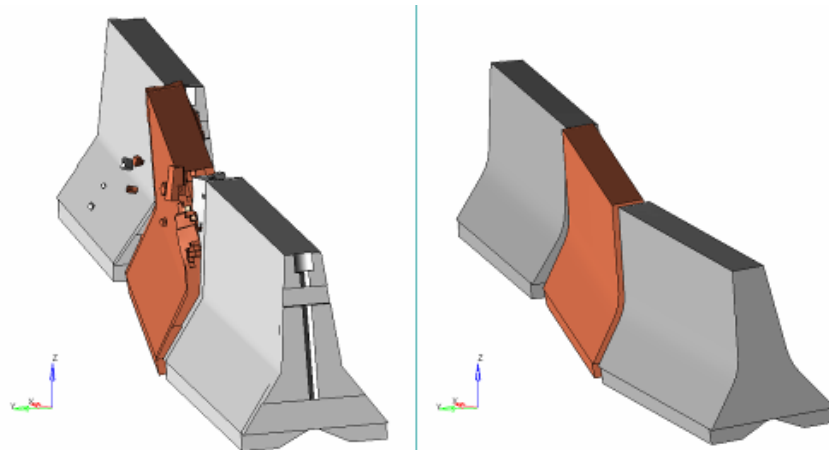
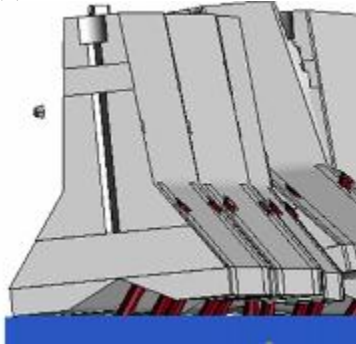

Figure 3 Modified WSDOT pinned barrier model.



(a) Increased barrier rotation in modified WSDOT model (left) versus old model (right)



(b) Lifting of barriers observed in modified simulation and test

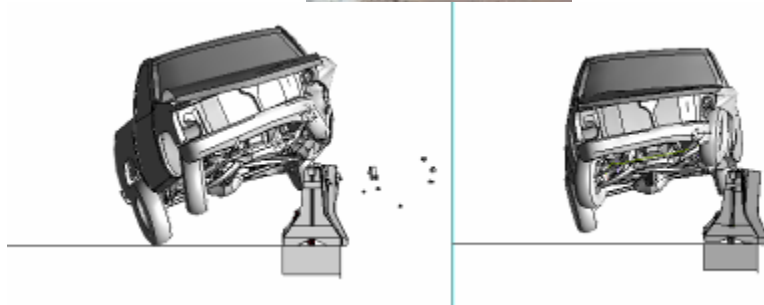

(c) Crash test (top), modified simulation (left), previous simulation (right)

Figure 4 Results of modified simulation of WSDOT barrier.

Pinned-Down Design for F-Shaped Barrier

Using the information gleaned from the WSDOT pinned barrier crash test, a new pinned barrier design was developed that adequately anchors the barriers, but does not necessarily accommodate all of the existing designs of the participating states.

The NJ profile of the barrier, which causes high vehicle climb, was changed to the more stable F-shape profile. After evaluating connection details of several barrier designs, the researchers selected Oregon DOT's pin-and-loop concrete barrier as the basis for the new pinned-down barrier connection details. This barrier connection incorporates "two sets of the three loops" made of $\frac{3}{4}$ -inch (19.1 mm) diameter smooth bar steel. The connecting pin is 1-inch (25.4 mm) in diameter and the gap between adjacent barrier segments is also 1-inch (25.4 mm). The length of the barrier segments is 12.5 feet (3.81 m).

The pin-down design incorporated two drop-pins per barrier segment. To better resist barrier rotation under vehicle impact, the drop-pin angle relative to the ground was reduced to 40°. Rebar details were modified to ensure that at least one longitudinal rebar passes below the drop-pins. The thickness of the drop-pin cap was also increased to $\frac{1}{2}$ inch (12.7 mm) as the thinner $\frac{1}{4}$ -inch (6.4-mm) cap was easily peeled off one of the pins in the WSDOT barrier test.

The FE model of the new drop-pin design incorporated similar modeling techniques used in the modified WSDOT pinned barrier simulations. Simulations were performed with the pinned-down barrier placed at the edge of the deck and at a six-inch offset from the edge.

The initial vehicle impact simulation was performed with the barrier placed at the edge of the deck drop-off. The results of simulation analysis indicate that the vehicle was successfully redirected. The maximum deflection of the barrier system was 6.5 inches (165.1 mm).

Due to the change in the profile of the barrier (i.e. from NJ profile to F-shaped profile), and other design changes such as the decrease in the drop-pin angle and stiffer solid steel loops in the pin-and-loop connection, the climb of the vehicle was reduced in the new pinned-down barrier simulation. The comparison between vehicle climb in the modified WSDOT pinned barrier simulation and the new F-shaped barrier simulation is shown in Figure 5a.

The roll angle of the barriers during impact was also significantly reduced between the new F-shaped barrier simulation and the modified WSDOT pinned barrier model. This difference for the barrier segment exhibiting maximum roll in both designs is shown in Figure 5b. The reduction in the angle of the drop-pins helped restrain barrier-roll and prevented the lifting of the barriers that was observed in the WSDOT test and simulation. The reduction in the barrier lift between the two designs is shown in Figure 5c.

A simulation with the barrier placed at a 6-inch (152.4-mm) lateral offset from the edge of the deck drop-off was also performed. The objective of this simulation was to investigate if allowing lateral off-set behind the barrier would positively affect barrier performance by reducing barrier roll. Simulation results did not indicate any significant difference in the barrier roll as shown in Figure 5d.

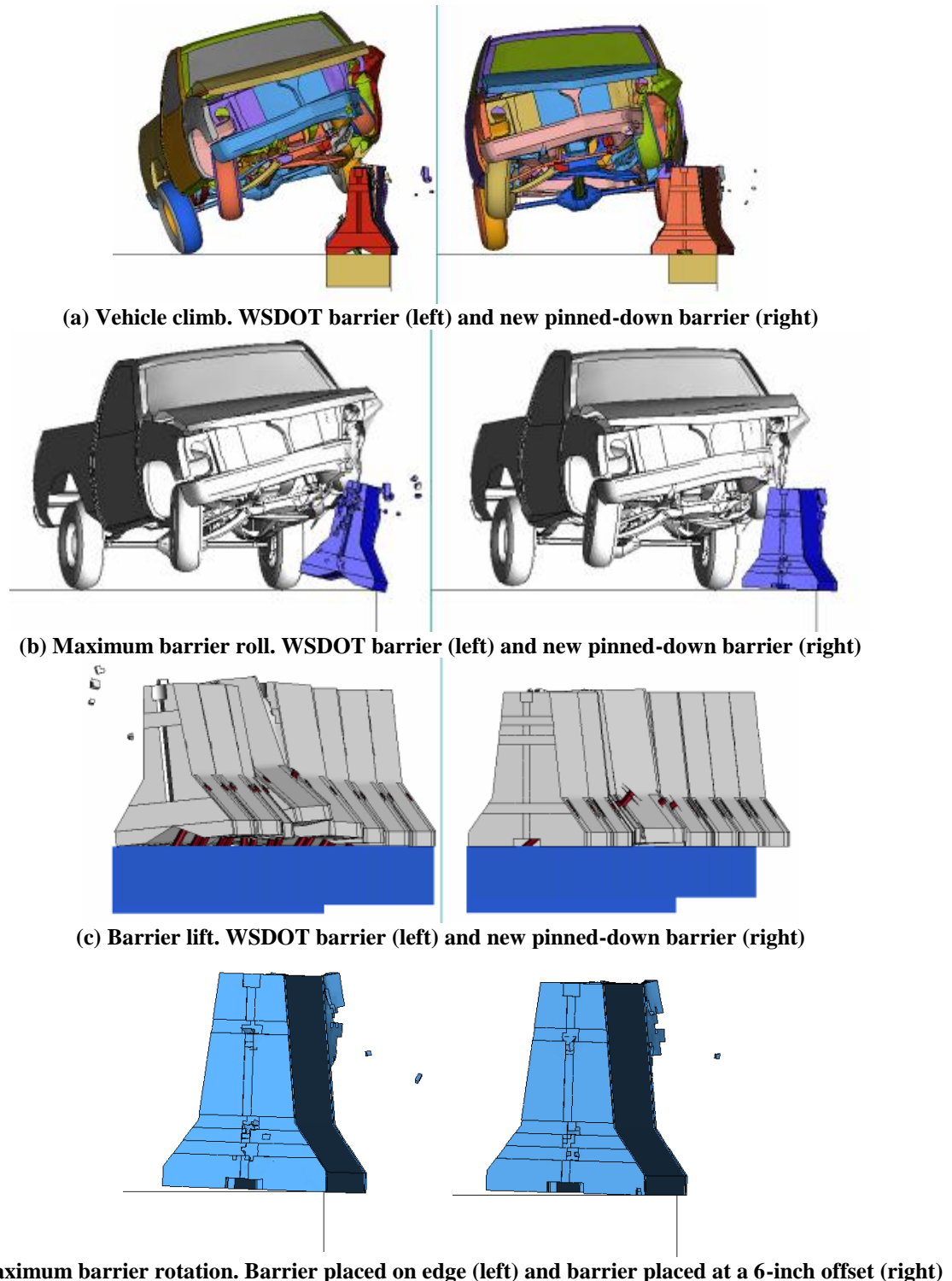

Figure 5 Simulation analysis results for the new pinned-down barrier.

While the simulation results indicated an improvement in vehicle climb with the new F-shaped pinned-down barrier compared to the WSDOT pinned barrier design, the vehicle still exhibited a relatively high amount of climb. This high climb is inherent in impacts with safety

shaped barriers and is aggravated by the barrier roll angle. Other aspects of the barrier performance, such as barrier roll and barrier lift were significantly improved in the new F-shaped pinned-down barrier. It was therefore concluded that even though the barrier may cause relatively high vehicle climb, the new pinned-down design has a reasonable chance of passing the NCHRP Report 350 Test Level 3 criteria. Subsequently, a crash test was performed, the details of which are presented next.

Crash Testing With Pinned F-Shaped Barrier

A crash test was performed for Test Designation 3-11 of NCHRP Report 350 (i.e. 4,409-lb (2000 kg) pickup impacting at 62.2 mph (100 km/h) and 25°). A 100-ft long installation that was comprised of eight 12.5 ft long F-shape temporary concrete barrier segments was used in the crash test. Details of the barrier design are shown in Figure 6. Adjacent barrier segments were connected using a pin-and-loop type connection.

Two 1.875-inch (47.6-mm) diameter holes inclined 40° from the ground, were cast into the toe of each barrier segment. The holes started from the traffic face of the barrier and exited near its bottom centerline. The holes in the barrier were used as a guide to drill 1.75-inch (44.5 mm) diameter holes into the un-reinforced concrete pavement. The depth of the holes inside the pavement was 6.25 inches (158.8 mm) when measured vertically.

A 1.5-inch (38.1 mm) diameter and 21.25-inch (539.8 mm) long ASTM A36 steel drop-pin was placed into each hole to lock the barrier in place. Inside the barrier segments, a 22-inch (558.8 mm) long U-shaped #4 bar was diagonally placed at the location of each drop-pin hole.

A 2000 Chevrolet C2500 pickup truck with test inertia and gross static weight of 4,674 lbs (2120 kg), traveling at a speed of 62.7 mph (100.9 km/h), impacted the installation 4.0 ft (1.22 m) upstream of joint 3-4 at an impact angle of 25.4°. The pickup was successfully contained and redirected in an upright manner. The vehicle lost contact with the barrier at 0.847 seconds. Exit speed and angle could not be obtained due to excessive dust. The maximum occupant impact velocity and ride-down acceleration were 6.19 m/s (20.3 ft/s) and -6.4 g, respectively, which are below the desirable range of NCHRP Report 350. The maximum roll angle was 41°. Maximum exterior crush to the vehicle was 21.7 inches (551.2 mm) and the maximum occupant compartment deformation was 1.1 inches (28 mm) in the left-side firewall area near the toe pan with some separation in the seam.

Damage to the barrier is shown in Figure 7. Some spalling was observed in the vicinity of the impact, but the damage to the barriers was moderate. Maximum permanent and dynamic deflections of the barrier were 5.76 inches (146.3 mm) and 11.52 (292.6 mm) inches, respectively. The drop-pins adjacent to the impact joint were deformed, but none of the pins pulled out of the concrete pavement. There was no significant damage caused to the concrete pavement. Further description and details on crash test results can be found in Sheikh et al. ⁽⁵⁾

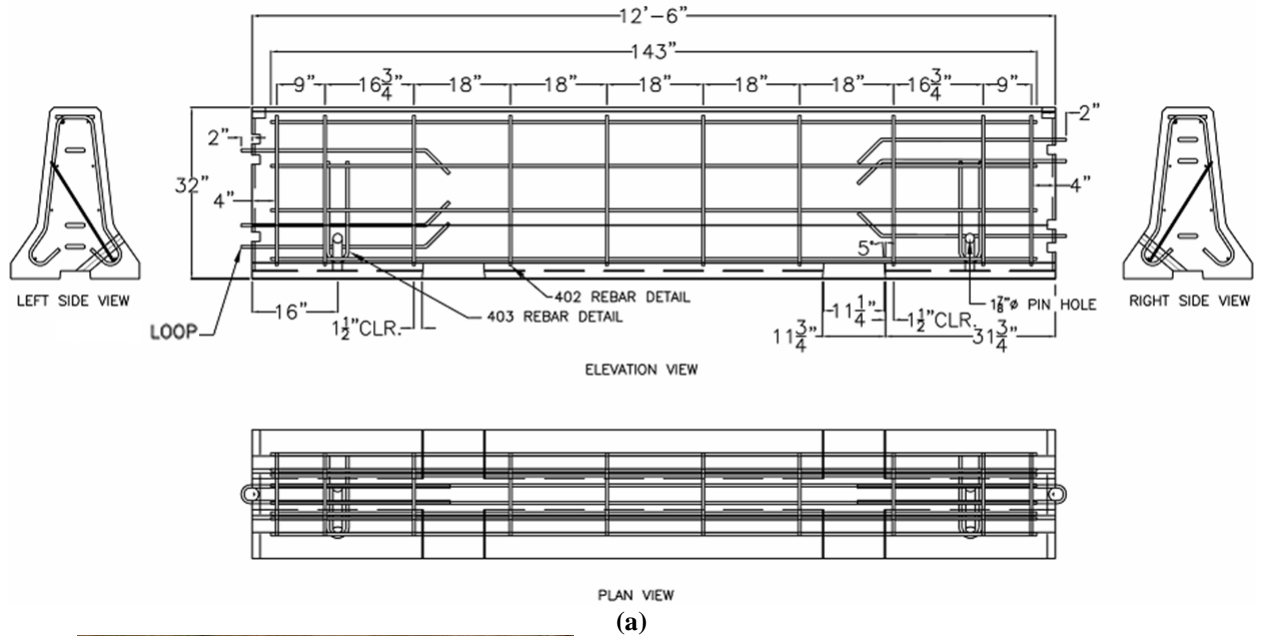

Figure 6 Pinned-down F-shaped temporary barrier before testing.



Figure 7 Pinned-down F-shaped temporary barrier after testing.

Conclusions

In this research, a new restrained F-shaped temporary concrete barrier was developed that is easy to install, inspect, and remove, and minimizes damage to the bridge deck or concrete pavements. The mechanism uses the pinned-down approach to restrain the barriers.

For installation, precast inclined holes in the barrier are used as a guide to drill holes in the underlying concrete pavement or deck. The barrier is then restrained by simply dropping the pins into these holes.

The pinned-down barrier was developed for NCHRP Report 350 TL 3 requirements through extensive use finite element analysis. The performance of the final design was evaluated by conducting a full-scale vehicle impact crash test. The occupant risk factors were within the preferred limits and even though the barrier sustained some damage that would require repair, the damage was moderate. The maximum permanent and dynamic barrier deflections were 5.76 and 11.52 inches (146.3 and 292.6 mm), respectively. There was no significant damage to the underlying concrete pavement.

References

1. W. L. Beason and D.L. Bullard, Jr., *Development of a Limited-Slip Portable Concrete Barrier Connection*. Research Report 1959, Texas Transportation Institute, College Station, TX, 1993.
2. B.W. Bielenberg, R.K. Faller, D.L. Sicking, J.R. Rohde, J.D. Reid, and J.C. Holloway, *Development of a Tie-Down Systems for Temporary Concrete Barriers*, Midwest Roadside Safety Facility, Lincoln, Nebraska, 2002.
3. K.A. Polivka, B.W. Bielenberg, R.K. Faller, D.L. Sicking, J.R. Rohde, J.D. Reid and J.C. Holloway, *Development of a Steel H-Section Temporary Barrier for Use in Limited Deflection Applications*. Midwest Roadside Safety Facility, Lincoln, Nebraska, 2003.
4. K.A. Polivka, R.K. Faller, J.R. Rohde, J.C. Holloway, B.W. Bielenberg, and D.L. Sicking, *Development and Evaluation of a Tie-Down Systems for Redesigned F-Shape Concrete Temporary Barrier*, Midwest Roadside Safety Facility, Lincoln, Nebraska, 2003.
5. H.E. Ross, Jr., D.L. Sicking, R.A. Zimmer and J.D. Michie, *Recommended Procedures for the Safety Performance Evaluation of Highway Features*, National Cooperative Highway Research Program Report 350, Transportation Research Board, National Research Council, Washington, D.C., 1993.
6. N. M. Sheikh, R. P. Bligh, and W. L. Menges, *Crash Testing and Evaluation of the 12 ft. Pinned F-shaped Temporary Barrier*, Research Report 405160-3-1, Texas Transportation Institute, College Station, TX, 2008.
7. Buth, C. E., N. M. Sheikh, R. P. Bligh, W. L. Menges, and R. H. Haug, *NCHRP Report 350 Testing of Montana Portable Concrete Safety Shape Barriers*, Report FHWA/MT-03-002/8162. Texas Transportation Institute, College Station, April 2003.