

Validation of a Loading Model for Simulating Blast Mine Effects on Armoured Vehicles

Kevin Williams*

Weapon Effects Section
Defence R&D Canada - Valcartier

Scott McClennan

Department of Metals and Materials Engineering
University of British Columbia

Robert Durocher

Weapon Effects Section,
Defence R&D Canada - Valcartier

Benoit St-Jean

Weapon Effects Section
Defence R&D Canada - Valcartier

Jocelyn Tremblay

Weapon Effects Section
Defence R&D Canada - Valcartier

*Corresponding author. Structural Dynamics and Simulation Group, Weapons Effects Section, Defence R&D Canada – Valcartier, 2459 Pie-XI Blvd. North, Val-Bélair, QC, Canada, G3J 1X5. Tel: (418) 844-4000 ext 4238, FAX: (418) 844-4502, e-mail: kevin.williams@drev.dnd.ca

Abbreviations:

ALE Arbitrary Lagrangian Eulerian
DOB Depth of Burial
DRDC Defence R&D Canada
LAV Light Armoured Vehicle
RHA Rolled Homogeneous Armour

Keywords:

Anti-vehicular Mine, Armoured Vehicle, Blast Loading, Verification

ABSTRACT

An ongoing program at Defence R&D Canada to reduce the vulnerability of Light Armoured Vehicle (LAVs) to anti-vehicular blast mines is relying heavily on LS-DYNA to help design and optimize add-on armour systems. A significant challenge in the numerical modelling work is the development of an accurate, or at least representative, loading history for the pressure and momentum transfer from the detonation of a buried blast mine. Arbitrary Lagrange-Eulerian (ALE) techniques offer some promise but the analysis is very computationally intensive. Another option that is more attractive from the point of view of simplicity (implementation and computation time) is an empirically based loading model. The LS-DYNA implementation of the CONWEP blast equations (*LOAD_BLAST) is one such example. While some authors have used this model to predict the effects of mine blasts on vehicle structures, there are significant limitations in this model. A more advanced empirical model for predicting the effects of blast mines on structures was developed for the U.S. Army Tank Automotive Command (TACOM) by Southwest Research Institute. This model has been implemented by the Defence R&D Canada - Valcartier (DRDC - Valcartier) in a pre-processor for LS-DYNA. A parameter study has been conducted using this implementation of the impulse model and the results are compared to those obtained from the CONWEP blast model. Validation is based on a series of experiments conducted at DRDC - Valcartier using square aluminium and steel test panels subjected to detonations of buried charges (surrogate mines) of 6 kg of C-4 explosive.

INTRODUCTION

The vulnerability of light armoured and soft skinned vehicles to anti-vehicular blast mines is well known and Defence R&D Canada – Valcartier (DRDC - Valcartier) has been involved in the development of protection systems for a range of vehicles for over 8 years. Recently, numerical modeling with LS-DYNA (Hallquist, 2001) has begun to play a very significant role in the design and validation of these systems (Williams, 1999 and Williams and Poon, 2000). The development of a comprehensive mine protection system requires the understanding of the effects of blasts on the vehicles and their crews. One of the most significant challenges in modeling these types of events is applying the appropriate loads to the vehicle model. In this study, two empirical loading models are compared.

CONWEP AirBlast Functions

The *LOAD_BLAST boundary condition in LS-DYNA is based on an implementation by Randers-Pehrson and Bannister (1997) of the empirical blast loading functions implemented in the CONWEP code (Kingery and Bulmash, 1984). The blast functions can be used for two cases, the free air detonation of a spherical charge and the surface detonation of a hemispherical charge. While the surface detonation approaches the conditions of a mine blast, anti-vehicular mines are most commonly buried anywhere from 5 to 20 cm (sometimes more if a road is resurfaced for example) below the surface of the soil. The depth of burial, among other things, has a significant effect on the energy directed on the target by funnelling the force of the blast upwards. Other variables such as soil moisture content and soil type have an equally important effect on the mine. None of these effects are included in the CONWEP blast model and the only variable available is the mass of explosive.

U.S. Army TACOM Impulse Model

The empirical relationship developed by Westine *et al.* (1985) at Southwest Research Institute under contract to the U.S. Army TACOM predicts the impulse applied by a buried mine to a plate at a given offset from the mine. The model is based on a series of tests that were conducted to measure the impulse at various locations above a land mine explosion. The data gathered from these tests was used to develop an empirical model that accounts for effects such as mine depth of burial, charge size, target height, and soil density. The output is a specific impulse, i_n :

$$i_n = f(r, d, D_{mine}, s, \rho_{soil}, m_{mine}, \beta, \theta) \quad (1)$$

where r is the radius from the mine centre to the target, d is the depth of burial, D_{mine} is the diameter of the mine, s is the distance from the centre of the mine to the target, m_{mine} is the mass of the mine, β is the angle from the mine centre to the target, and θ is the orientation of the plate, as shown in Figure 1.

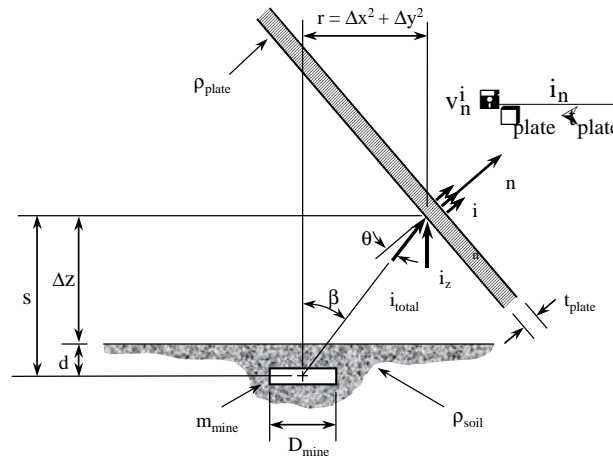

Figure 1. Definition of variables in the US Army TACOM Impulse Model (Adapted from Westine *et al.*, 1985).

Knowing the plate thickness and density, one can calculate the initial velocity as follows:

$$v_n = \frac{I}{m_{plate}} = \frac{(i_n \cdot A_{plate})}{m_{plate}} \cdot \frac{t_{plate}}{t_{plate}} = \frac{i_n}{\rho_{plate} t_{plate}} \quad (2)$$

where I is the total impulse, m_{plate} is the mass of the plate, A_{plate} is the area of the plate, t_{plate} is the thickness of the plate and ρ_{plate} is the density of the plate. It is important to note that the impulse model was developed based on charges of 0.27 kg (1/8 lbs). By applying the model to typical anti-vehicular mines (on the order of 6 to 10 kg) we are assuming that the results scale linearly with mine mass. Some validation work by Westine *et al.* (1985) and Morris (1993) supports this assumption.

APPROACH

Experimental Tests

Field trials were conducted by DRDC - Valcartier in May of 2000 to study the effects of mine blasts on 182.88 cm x 182.88 cm (6' x 6') 5083-H131 aluminium armour and RHA plates. These trials provided an opportunity to validate loading models using a relatively simple test case.

The experimental test set-up is shown schematically in Figure 2.

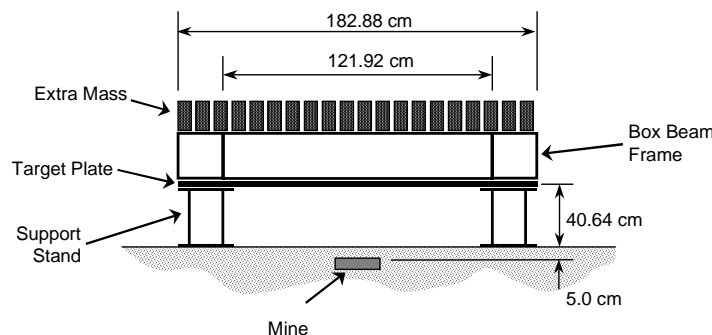

Figure 2. Experimental set-up.

The target plate was supported on its four corners by stands. The box beam frame that sits on top of the plate was used to hold the plate in place and provides for a 121.92 cm square (4' x 4') opening over the plate. Additional masses totalling 10,620 kg were placed on top of the frame. The mass of the frame and weights were representative of the mass of a LAV.

A 6-kg cylindrical charge ($l/d = 3$) of C-4 was used as a surrogate for an anti-vehicular mine. The mine was buried 5 cm below the surface of the soil, centred on the plate.

The plate was instrumented with strain gauges and piezo-pins (contact pins), as shown in Figure 3. Three piezo-pin arrays were used: two with three pins spaced 50.8 mm (2 in) apart and one with five pins also spaced 50.8 mm apart. Other methods of measuring the deformation (e.g. radar) were tried, but none proved successful. While the resolution provided by the piezo-pin arrays was not ideal, they did provide some good data on the displacement histories.

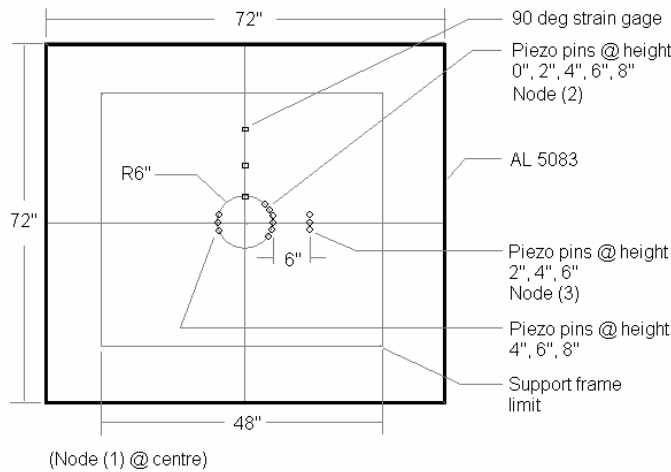

Figure 3. Location of piezo-pins and strain gauges in experimental set-up.

The post-test deformation profile of the plate was also measured.

Finite Element Model

The FEMAP CAD/CAE software package (SDRC, 2000) was used as a pre-processor to build the solid model and finite element mesh of the experimental set-up. The inherent symmetry of the test set-up was used and only a quarter of the plate and loading frame were modeled (see Figure 4) with appropriate boundary conditions applied along the symmetry planes. The model mesh consisted of 5055 nodes and 4880 elements. The additional weights on top of the frame were modelled by assigning lumped mass elements to the nodes on the top of the frame.

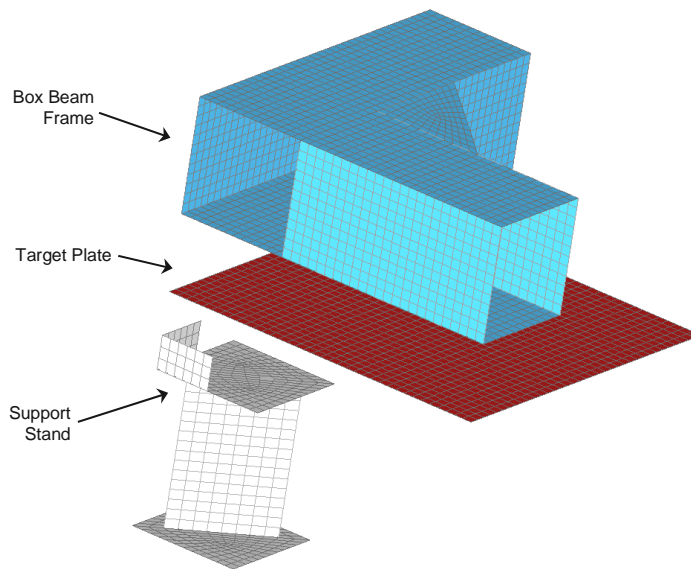

Figure 4. Finite element model of the experimental test set-up.

The entire model was constructed from Belytschko-Tsay shell elements with 5 integration points. Material model 3 (*MAT_PLASTIC_KINEMATIC) was used for the frame and target plate. The material properties used are shown in Table 1.

Table 1. Material properties used in the support frame and plate models.

Property	Steel SAE 1020	Aluminium Al 5083-H131	Steel RHA
Component	Support Frame	Target	Target
Density, ρ (kg/m^3)	7830	2768	7850
Elastic Modulus, E (MPa)	205.0x10 ³	70.33x10 ³	197.5 x10 ³
Poisson's Ratio, ν	0.30	0.33	0.30
Yield Stress, σ_Y (MPa)	350	322	1320
Tangent Modulus, E_T (MPa)	636	340	1810
Failure Strain, ϵ_f (mm/mm)	N/A	0.25	0.12
Plate Thickness, t_{plate} (mm)	12.7	31.75	6.35

A *CONTACT_AUTOMATIC_SINGLE_SURFACE definition with the default parameters was used to ensure contact between the various components. The residual deformation was determined using the *INTERFACE_SPRINGBACK_SEAMLESS option although the springback observed was minimal.

Loading Models

Two loading models were investigated; the CONWEP blast model based *LOAD_BLAST boundary condition implemented in LS-DYNA (Randers-Pehrson and Bannister (1997)) and the mine impulse loading model developed by Westine et al. (1985) for the U.S. Army TACOM.

CONWEP Blast Loading Model. The *LOAD_BLAST boundary condition cards were used with a baseline charge size of 6.84 kg of TNT which is equivalent to 6 kg of C-4 if one uses the 1.14 TNT energy release equivalence commonly quoted for air blast with C-4. Recent collaborative work with DRDC – Suffield and U.S. Army TACOM (Bergeron, 2001) indicates that this equivalence factor does not apply to buried mines.

U.S. Army TACOM Impulse Model. A pre-processor for LS-DYNA has been written by DRDC – Valcartier (Dumas and Williams, 2002) that implements the empirical equations from Westine *et al.* (1985). The program uses ray tracing to project a ‘line of sight’ from the mine to the model nodes thereby determining which nodes are shielded by other elements. Initial velocities are only applied to the nodes that are initially exposed to the blast. The program takes as input the mine and soil parameters (i.e. mine size, location, depth-of-burial, soil density, etc.) and the LS-DYNA input deck. No special provisions for the blast loading (e.g. location of the mine) are necessary in the input deck that is fed to the pre-processor. This is an advantage when setting up complex vehicle models, for example. Material data and element thicknesses already in the LS-DYNA input deck are used to calculate the appropriate initial nodal velocities. A new LS-DYNA input deck is written which includes the required *INITIAL_VELOCITY_NODE cards.

The baseline mine and soil conditions used for the analytical model are presented in Table 2. Note that the depth of burial used by the model is measured from the surface of the soil to the centre of the mine. This is in contrast to the more usual definition of the depth relative to the top surface of the mine (i.e. the overburden). As a result, the DOB is 8.81 cm (5 cm + half the mine thickness).

Table 2. Baseline mine and soil conditions.

Property	Value
Mine Mass	6 kg
Mine Diameter	25.4 cm
Mine Thickness	7.62 cm
Depth of Burial	8.81 cm
Soil Density	2301 kg/m ³

RESULTS

Figure 5 shows a typical sequence of deformation plots for the aluminium target model.

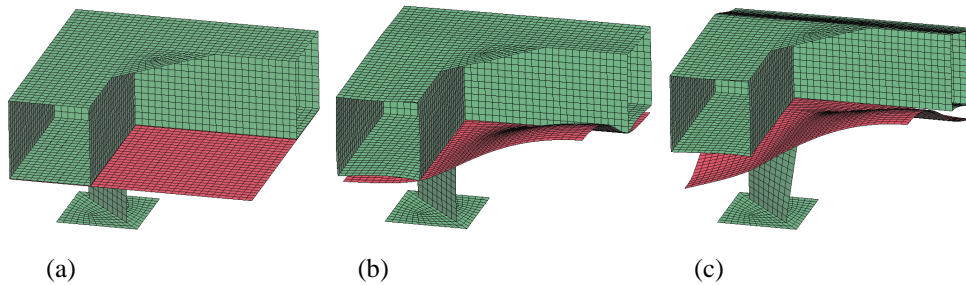

Figure 5. Predicted deformation history for a 31.75 mm (1.25 in) thick 5083-H321 aluminium plate subjected to the blast from a buried 6-kg C-4 charge.

CONWEP Loading Model

Initial results showed that the maximum residual deflection of the aluminium target plate were quite a bit lower than the measured values. The model predicted 115 mm of displacement whereas the measured value was 298 mm. As a result, the charge size was scaled (see Figure 6) in order to try to match the experimental data.

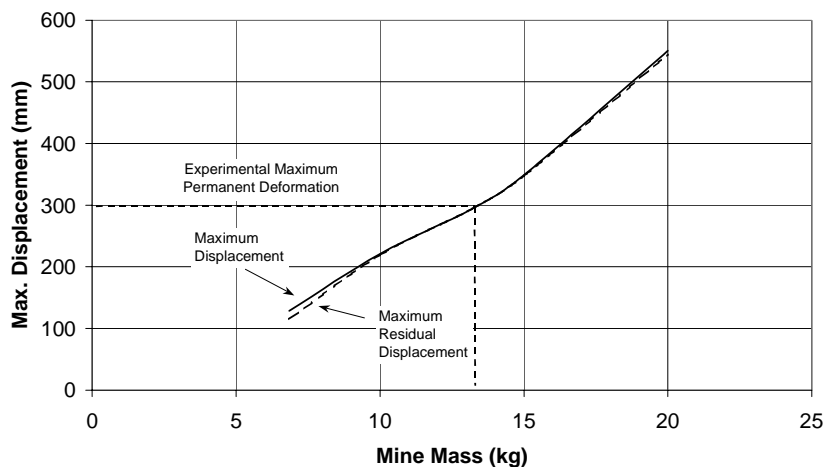

Figure 6. Predicted maximum displacement as a function of mine mass for the CONWEP blast loading model

Increasing the mine mass to 13.2 kg of C-4 gives a maximum deflection of 293 mm. The under prediction of the maximum displacement can be traced to the roots of the empirical equation. The data used to develop the equations were based on experiments with surface laid charges where there is no confinement. It is the confining effect of the

soil which is the mechanism that directs more of the blast energy up towards the centre of the target rather than allowing it to vent to the sides. Because the plate is directly above the charge, the charge size can be scaled, albeit by a factor of 2.2, to improve the predicted maximum displacement but it is likely that this parametric study would need to be conducted with each new target geometry.

US Army TACOM Impulse Model.

Initial results for the predicted residual deformation (515 mm) showed displacements that were higher than the deformation measured after the trials (298 mm). These results are consistent with an earlier application of the model (Williams, 1999 and Williams and Poon, 2000) in which a scaling factor was applied to the predicted impulse. Figure 7 shows the results of a series of runs that were performed to match the predicted deformation with the experimental measurements.

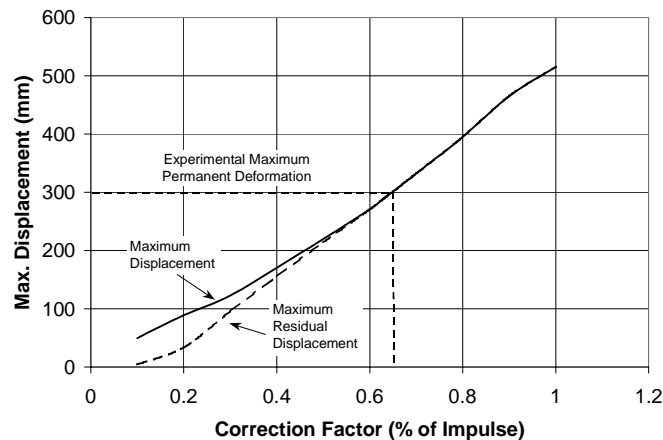

Figure 7. Predicted maximum residual displacement as a function of correction factor for the U.S. Army TACOM impulse model.

The results of this parameter study showed that the impulse had to be reduced to 66% of the baseline value in order to match the experimental results. This value of 66% is significant because it is precisely the same value that has been found on two separate occasions with two different target geometries and target materials tested at the DRDC – Valcartier test range. There are a number of possible explanations but it is believed that the scaling relates to the particular soil conditions at the test site. In particular, variables such as soil type and moisture content are not included in the model. The fact that it is consistent across a range of targets means that the model can be used effectively as a predictive tool.

Comparison of the Two Models

In

Figure 8, the predicted deformation history is compared to the experimental measurement for a series of piezo-pins located 30.5 cm (12 in) from the centre of the plate.

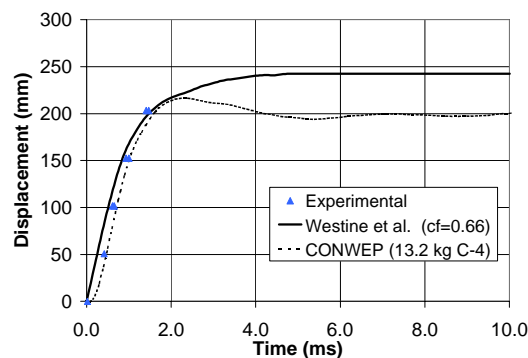

Figure 8. Comparison of predicted and measured deformation history 30.5 cm from the centre of the plate along symmetry plane.

While it would have been interesting to have more piezo-pins offset 20-25 cm from the plate, the numerical model shows excellent agreement with the measurements that were taken.

In Figure 9, the final profile of the plate is compared with experimental results.

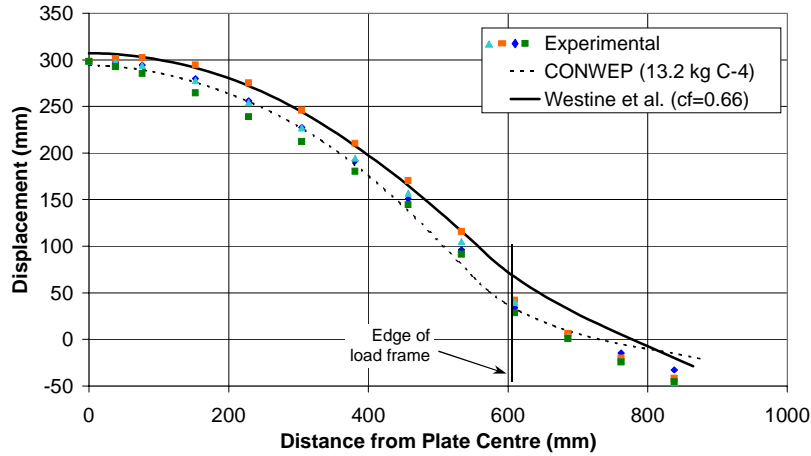

Figure 9. Comparison of predicted and measured final plate profile along the symmetry plane of the plate.

The agreement is excellent. Note that the experimental data is a collection of the results taken from the 4 symmetry planes of the plate and the scatter in the experimental data indicated a slightly asymmetric loading.

Studying the Effect of Soil Density and DOB

Further runs were performed with the Westine *et al.* (1985) model to investigate the effects of the depth of burial and the soil density. The results are shown in Figure 10 and Figure 11.

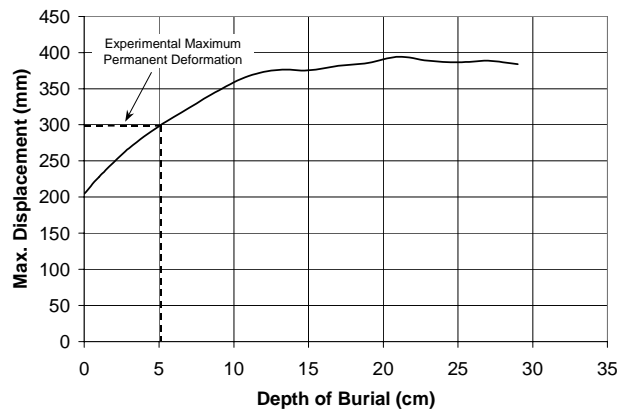

Figure 10. Predicted effect of the depth of burial on the maximum residual displacement for a 6-kg C-4 mine surrogate using the Westine *et al.* (1985) model.

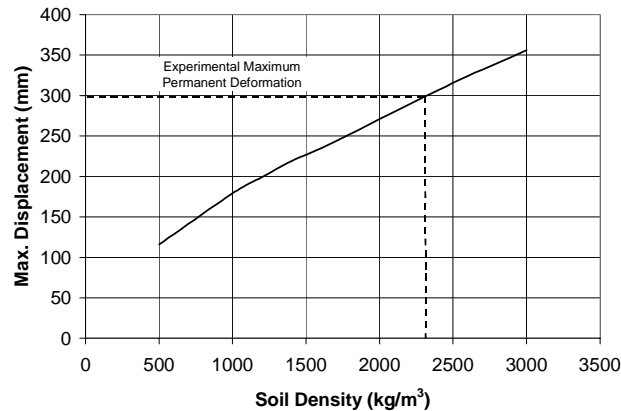

Figure 11. Predicted effect of the soil density on the maximum residual displacement for a 6-kg C-4 mine surrogate using the Westine *et al.* (1985) model.

It is interesting to note that the competing mechanisms of the confinement provided by increasing the DOB and the weight of the overburden that must be moved by the mine are correctly predicted when the depth of burial is increased (i.e. the plateau in Figure 10). Also, note that the predicted maximum deformation of 204 cm at a 0 cm DOB approaches the baseline prediction of the CONWEP (i.e. surface detonation) model of 115 mm although there is still a significant difference. The same trend is highlighted in Figure 11. With a very low soil density (i.e. a very low confinement), the Westine *et al.* model predicts a much lower maximum displacement.

RHA Plate Response

Finally, the U.S. Army TACOM impulse model was applied to a RHA steel plate. The same loading conditions were used (a 6-kg C-4 charge buried 5 cm below the soil, centred on the plate). The experimental and numerical results are shown below in Figure 12. In the test, the petals of the steel plate are curved back into the centre of the hole after impacting the additional masses (removed in photo) placed over the frame.

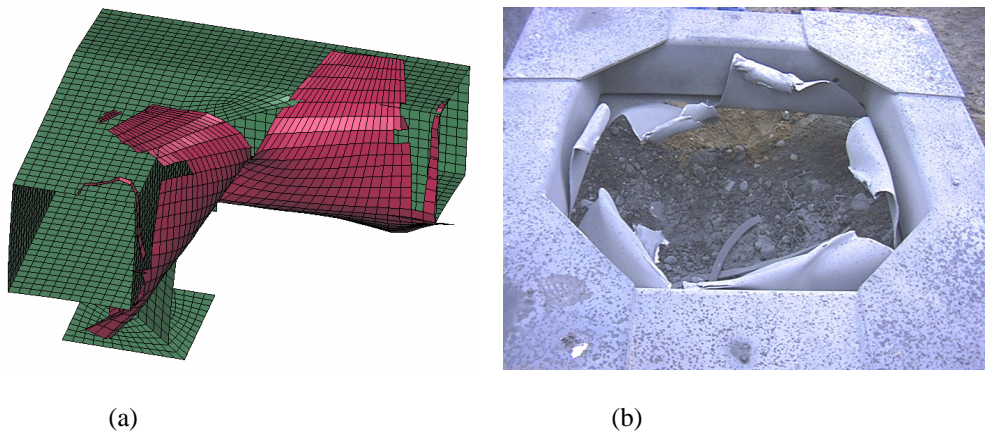

Figure 12. Comparison of (a) the predicted deformation of a 6 mm (0.25 in) rolled homogenous armour (RHA) plate subjected to the blast from a buried 6-kg C-4 charge and (b) the experimental result.

SUMMARY

Two empirically based loading models for mine blasts have been applied to model a simple experimental test involving the detonation of a 6-kg C-4 mine surrogate buried under a 182.88 cm (6') square plate. When applied as a mine blast loading model with the baseline conditions, the CONWEP hemispherical surface burst model (*LOAD_BLAST) showed poor results when compared to the experimental measurements. The model has no way to account for the confinement provided by the soil which is the mechanism that leads to the increased destructive power of an equivalent buried charge versus a surface laid charge. Scaling the charge size can give better agreement

with experimental data however, the application of the model to mine blast effects on general structures (e.g. vehicles) is likely to be severely limited because of the incorrect distribution of the loading.

The baseline run of the empirical mine loading model developed by Westine *et al.* (1985) showed a significant over prediction of the deformation of the plate. Scaling the impulse by a factor of 66% gave good agreement with the deformation history and deformation profile measured in the experiments. This scaling factor was in accordance with previous numerical and experimental comparisons for vehicle models. This indicates that the factor is likely a characteristic of the soil properties at the DRDC – Valcartier test site. The model correctly predicts the effects of the DOB and soil density.

An empirical loading function can be sufficiently accurate for predicting mine blast effects on simple geometries if the user is careful to calibrate it against experimental results. However, when the complex interaction of the detonation products, soil, and debris with a more intricate target (e.g. a vehicle chassis) must be captured, one must turn to more sophisticated (and more computationally intense) fluid structure formulations such as the multi-material ALE approach implemented in LS-DYNA. This is the subject of continuing work.

ACKNOWLEDGMENTS

The authors would like to thank their colleague Dr. Dennis Nandlall for his support and suggestions during the investigation.

REFERENCES

- BERGERON, D. (2001). Private Communication, Defence R&D Canada – Suffield, Suffield, AB.
- DUMAS, S. and WILLIAMS, K. (2002). “MinePre – Mine Blast Loading Pre Processor for LS-DYNA,” Defence R&D Canada – Valcartier, Val-Belair, QC.
- SDRC (2000). FEMAP 8.0, Structural Dynamics Research Corp, Exton, PA.
- HALLQUIST, J. (2001). LS-DYNA Users Manual – Version 960, Livermore Software Technology Corporation, Livermore, CA.
- KINGERY, C. and BULMARSH, G. (1984). “Airblast Parameters from TNT Spherical Air Burst and Hemispherical Surface Burst,” ARBRL-TR-02555, U.S. Army Ballistic Research Laboratory, Aberdeen Proving Ground, MD.
- MORRIS, B.L. (1993). “Analysis of Improved Crew Survivability in Light Vehicles Subjected to Mine Blast, Volume 1 - Technical Report,” SwRI Project No. 06-5095, U.S. Army Belvoir Research, Development and Engineering Centre, Fort Belvoir, VA.
- RANDERS-PEHRSON, G. and BANNISTER, K. (1997). “Airblast Loading Model for DYNA2D and DYNA3D,” ARL-TR-1310, Army Research Laboratory, Aberdeen Proving Ground, MD.
- WESTINE, P.S., MORRIS, B.L., COX, P.A., and POLCH, E.Z. (1985). “Development of Computer Program for Floor Plate Response from Land Mine Explosions,” Technical Report No. 13045, US Army Tank-Automotive Command, Warren, MI.
- WILLIAMS, K. (1999). “Floor Deflection of the LAV-III Caused by the Detonation of a 7.5 Kg Anti-Tank Mine Surrogate,” DREV TM-1999-154, Defence R&D Canada – Valcartier, Val-Belair.
- WILLIAMS, K. and POON, K. (2000). “A Numerical Analysis of the Effect of Surrogate Anti-Tank Mine Blasts on the M113,” DREV-TM-2000-007, Defence R&D Canada – Valcartier, Val-Belair, QC.