

**IN BORE BEHAVIOUR OF LARGE CALIBRE ARMOUR
PIERCING FIN STABILISED DISCARDING SABOT
PROJECTILES.**

*N.Eches, N.Paugain, C. Doffémont; Giat Industries,
Division des systèmes d'armes et de munitions.
7 route de Guerry, 18023 Bourges Cedex; France
Tel : +33 2 48 21 91 85 - Fax : +33 2 48 21 91 42.*

Introduction

The efficiency of large calibre armour piercing fin stabilised discarding sabot projectiles (APFSDS) is primarily linked to their terminal ballistics performances. But other parameters, such as its accuracy and its yaw at the impact have also a large influence on the performance. These two parameters magnitude, as well as the survivability of the projectile during the launch phase are greatly affected by the interaction between the projectile and the gun, also known as the “balloting”.

Nowadays, the accurate description of the rod free flight has been made possible thanks to Computational Fluid Dynamics calculations, allowing to predict the flight quality or the retardation, and back calculation of initial disturbances of an unexpectedly odd shot. But this situation is not true for the early moments of the firing sequence, i.e. the projectile in-bore travel and the sabot separation. For the latter, a long way to go remains. But, in the field of projectiles in-bore behaviour, a lot of works have been performed, using different numerical methods, which allowed scientists to make significant progress.

This paper describes some of the works performed in the Giat Industries Weapon and Ammunition Systems Division (DSAM), whose purpose was to understand how the interactions between the weapon and the projectile could affect its mechanical behaviour and its muzzle exit conditions.

The APFSDS

The APFSDS is nowadays the ultimate tank ammunition for the destruction of other main battle tanks. Its lethal power is due to the kinetic energy imparted to its long, slender and very heavy penetrator, impacting the target at velocities between 1.4 to 1.8 km/s. The penetrator is stabilised by the means of fins attached to its rear end, and a windshield on the front end reduces its aerodynamic drag. This so-called sub projectile is launched by the means of a sabot assembly, constituted of three aluminium petals, and a plastic obturator attached to the sabot bulkhead, whose function is to provide sealing between the projectile and the barrel wall (figure 1.) When the projectile lies in the barrel, the combustion of the propulsion propellant generates a large amount of hot gases, at high pressure, which push it to the muzzle. Once the projectile leaves the tube, the obturator breaks under the remaining gas pressure and the sudden stress relaxation, and the three sabots petals aerodynamically separate (figure 2.)

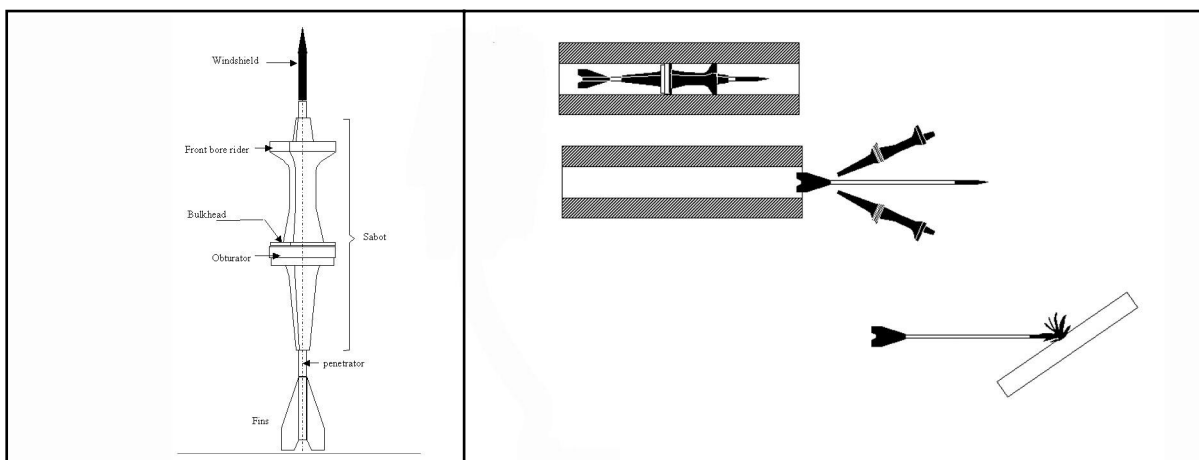

Figure 1: Sketch of an APFSDS

Figure 2: Sequence of an APFSDS firing.

In addition to the impact velocity, the nature of the rod material, and the length of the penetrator are the leading parameters for the perforation performance. This lead, in the recent past years, the USA, France, the U.K. and possibly some eastern countries to adopt penetrator made of depleted uranium (DU) alloy. In parallel, penetrators have been stretched, while their diameter tended to decrease. This increase of the L/D ratio of the penetrators, coupled with the decrease of elastic moduli due to the use of DU in replacement of tungsten alloys result in a greater flexibility of the projectile, which becomes more liable to bending and vibration under the transverse perturbations that can occur during the firing. This behaviour, called the balloting, may have to main effects:

- o The extra stresses generated by bending, vibration and transverse momentum may affect the survivability of the projectile during its travel through the gun.
- o As the muzzle exit behaviour sets the free flight movement initial conditions, it may affect both target accuracy and yaw, whose influence on the perforation is very sensible.

It is then necessary to take into account those aspects when designing a projectile.

Gun dynamics methods

Gun dynamics studies have really begun with the rise of relatively powerful computer systems. As the phenomena dealt with are primarily transient, but last a relatively long time (several milliseconds), the efficiency, in terms of accuracy and CPU time, of their numerical simulation is very closely linked to the available computer power. Two numerical techniques were developed in parallel.

The analytical method use a simplified model, based on a one-dimension description, with beam elements, following either Euler-Bernouilli or Timoshenko formulations. Existing softwares allow the consideration of a complete weapon system, including the cradle, recoil system or links with the vehicle. Geometrical non-linearities, such as clearances or contact are introduced by the means of springs and dampers or force-deflection curves. These codes are generally coupled with a lumped parameter Internal Ballistics code that gives the axial motion of the projectile. Some of the most well known models are:

- o Rascal, which is a 2D code developed by the US ARL (Erline et al., [1]),
- o Shogun, which address axisymmetric geometries, but 3D effects, and developed by Hopkins, also at the ARL ([2]).
- o RAMA, from the British RMCS, which, in addition to the transverse motion that follows Euler-Bernouilli theory, calculates the longitudinal vibrations of the gun using the waves propagation equations (Powell [3]).
- o Simbad is a commercial code, developed in the UK by D. Bulman ([4]), which follows the same basic principles than Rascal or Shogun, taking into account 3dimensionnal aspects of the problem. It includes an interesting feature for the study of APFSDS, which is a flexible projectile, with two separate parts: the rod and the sabot, linked by a non-linear interface.

On the other hand, the gun dynamics may be studied by finite element, using either modal techniques, or direct integration techniques. Because of the highly transient and non-linear aspects of the balloting phenomenon, including fast gap opening and closure, local material yielding, and large displacements, the natural technique to use is direct integration with an explicit numerical scheme.

In [5], D. Rabern performed a very comprehensive study of the effect of lateral disturbances on the M829 DU projectile, including numerical simulations validated by experimental measurement, by the means of in-bore flash X-rays. He pointed out the sensitivity of the barrel straightness defects, due to machining flaws, gravity droop or thermal stresses, on the projectile vibrations during its in-bore travel. His model only included a 180° representation of the breech, the barrel and the projectile. Slide surfaces were defined between the sabot petals, and between the obturator, as well as the front bore rider, and the tube inner wall.

Then Wilkerson, Hopkins and Held modelled complete gun systems, including the breech, the barrel, the cradle, the recoil system and the mount. ([6], [7]), with complete 360° meshes. Clearances between the different components, as well as pressure front along the barrel were included in those models, which allowed the confirmation of experimental results about the accuracy of APFSDS as a function of their balloting behaviour.

Study of the behaviour of 120mm APFSDS projectiles.

Context

Giat Industries, as one of the main European weapon system manufacturer, has been focusing efforts on this field of expertise since about 15 years. Numerous works have been performed using the SIMBAD software both in medium and large calibre applications. From 1993, works regarding barrel-APFSDS projectile interaction began, with a dual approach, including SIMBAD and LS-Dyna 3D studies. The first attempt was a coupling between both softwares. A first global simulation with SIMBAD gave the system response, which was then extracted to be injected in a local LS-Dyna model, comprising the projectile and a moving region of the barrel.

In 1998, Giat Industries contracted with the French Delegation Générale pour l'Armement (DGA) to study the influence of the different components of a large calibre cannon on its dynamic response during the firing event. A wide numerical programme, surveying most of the parameters defining a large calibre weapon, using an in-house customised version of the SIMBAD software, was performed. In parallel, the DGA performed a heavy test programme, at the ETBS firing range, to measure the dynamic response of the gun during the firing of APFSD and practice rounds of ammunition. In order to insure the validity of data gathered, numerous measurements means were used, summarized in the following sketch.

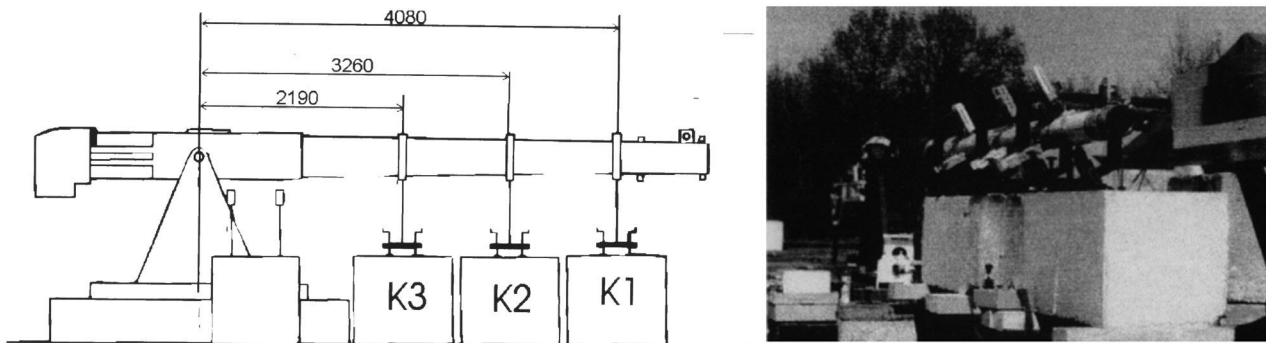

Figure 3: sketch and picture of the test set-up, with locations of the Kaman sensors relative to the trunnions pins (in mm).

The barrel displacement was tracked in three locations, by Kaman sensors, mounted in order to eliminate the barrel radial expansion, due to the gas pressure, from the measurements. Accelerometers were also placed on the barrel in two locations. Chamber piezo gages were used to measure the exact chamber pressure, while the in-bore axial projectile velocity was measured by the mean of Weibel radar. This latter data was then differentiated in order to yield both projectile acceleration and base pressure.

During this campaign, eight APFSDS were fired, which gave very consistent results. As an example, the graphs below show a compilation of the three Kaman sensors for every projectile.

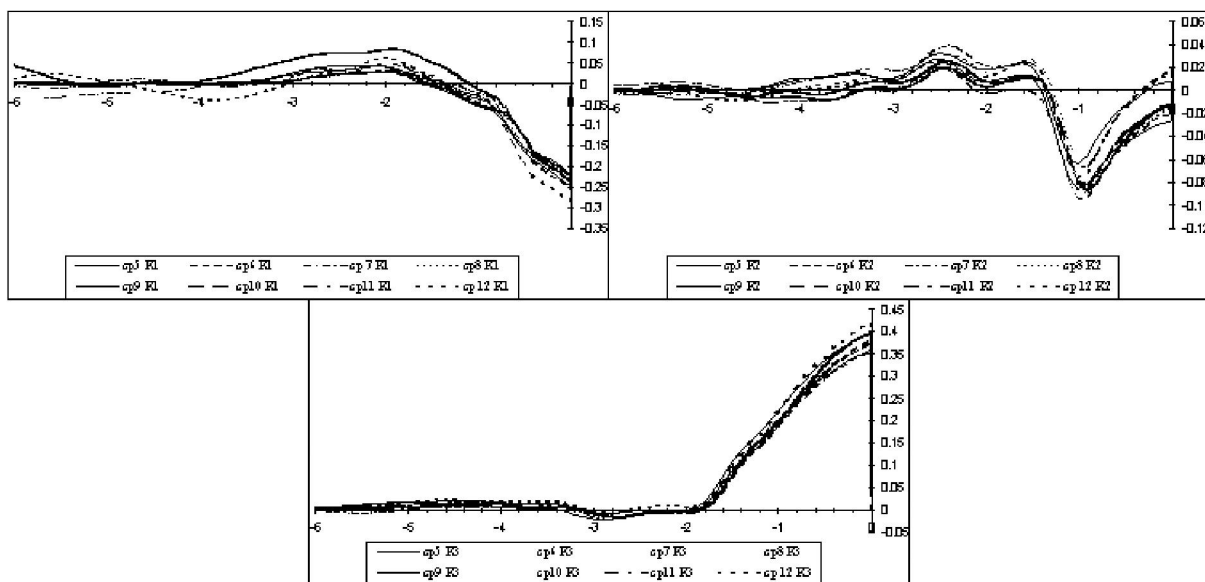

Figure 4: Barrel displacement as a function of projectile location for every APFSDS firings (Origin is the muzzle). K1 left above, K2 right above, K3 below. One can notice the consistency of the displacement within the whole serial.

A very extensive, reliable, and rather unique database was thus created. In order to take benefit of this huge amount of data, Giat Industries led with LS-Dyna 3D, on private funds, the simulation of a complete gun system, with the goal of a thorough description of the projectile-barrel interactions, in order to complete the outputs of the SIMBAD programme, whose purpose was more focused on the weapon behaviour.

The LS-Dyna 3D model

Geometry

The main goal of this study was to calibrate a modelling methodology, in order to be later in a position to predict with a reasonable accuracy the behaviour of a projectile during its in-bore travel. Thus, the exact configuration of the test campaign described above was modelled.

As a first stage of the study, only the vertical component of the motion is addressed. So, only one half of the structure is meshed.

The weapon is divided into two main components: the barrel and breech assembly, and the cradle assembly. The latter comprises a faithful geometric description of the tubular cradle, including fixtures for external devices, the body of the recoil system, the trunnions and the bearings between the cradle and the barrel.

The barrel is mapped around a centreline corresponding exactly to the centreline measured on the barrel used during the firings. Its profile is given below.

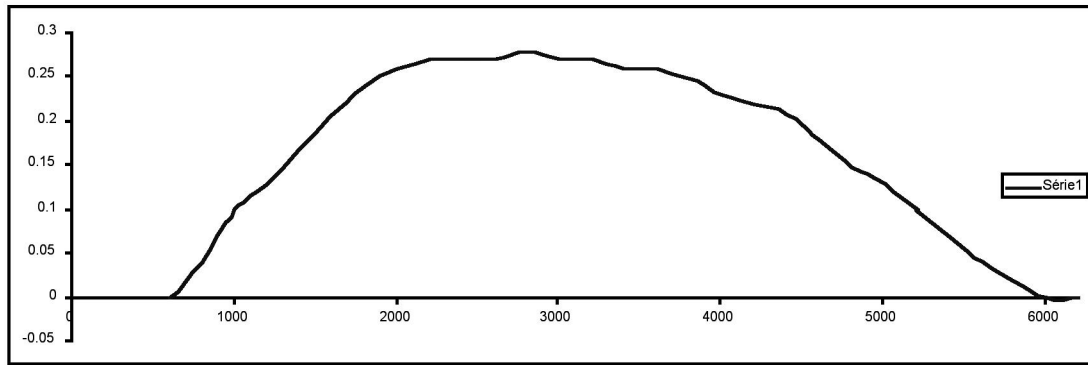

Figure 5: Straightness in the vertical plane of the barrel used for the firings, as a function of abscissa. (Straightness and abscissa in mm)

The barrel is meshed with 156 cells in length, 12 tangentially and two in the thickness. The breech is highly simplified, as its response is assumed to be of second order on the total response of the system, and its geometry rather complicated to mesh with hexahedrons. Nevertheless, its inertia matrix is conserved in order to keep the systems consistent.

The outputs of the SIMBAD study described above state that with the configuration of the Leclerc's gun, the recoil system and the elevation gear systems have a negligible influence on the dynamic response of the system, while the projectile is still in the barrel. These parameters begin to affect the gun vibration only after the exit of the projectile. So, they are not included in the model.

For the same reason, the mounting on which the gun is attached is not included in the model. Translation restraints are applied on the trunnions to represent the presence of the mounting.

The main difference with the works of Rabern, Hopkins and Wilkerson lies in the level of details in the projectile modelling. In the contrary with those works, where the three sabot petals were considered as separate assemblies, but were "welded" to the penetrator, here the penetrator-sabot interface is meshed in a realistic way, including the grooves actually present on both the rod and the sabot. Then, the rod and the sabot petals interact through a slide surface. The propulsion effort is thus transmitted from the sabot to the rod in the most possibly realistic way. Thanks to this methodology, we can take into account the clearance between the penetrator and the sabot assembly, the radial degree of freedom of the sabot in the gun tube, and also we prevent the over-stiffness of the projectile, resulting from the welding of the penetrator to the sabot.

Nevertheless, in order to avoid to deal with too many elements, the actual number of grooves is divided by two, and the geometry of the modelled tooth is such as the slopes and diameters are kept, as well as the total shear surface at pitch radius. The groove simplification is shown on the figure below.

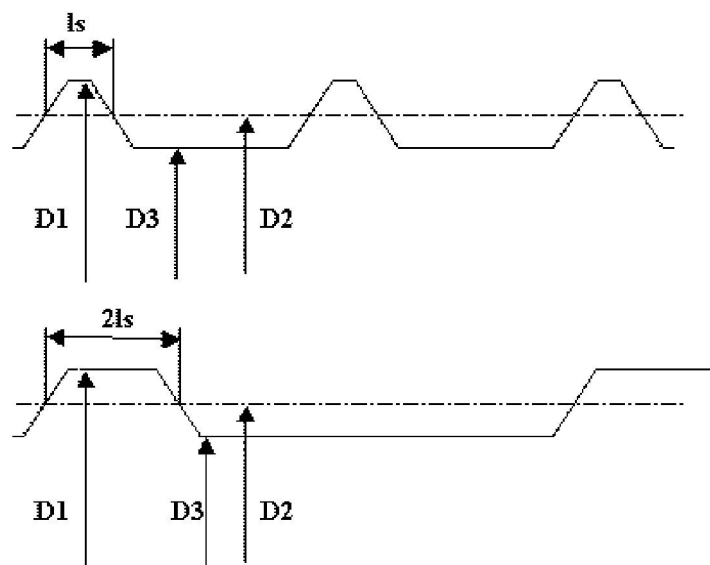

Figure 6: simplification of the rod-sabot interface. Above: actual geometry. Below: model.

The fin and the windshield-tip assemblies are modelled as equivalent masses and inertia, still in a seek of simplification. The obturator is modelled very faithfully, with a rather fine mesh, in order to deal with the large local deflections expected in this area, made of very soft material, and on which high pressures are applied. The whole model contains about 22000 elements and 33500 nodes.

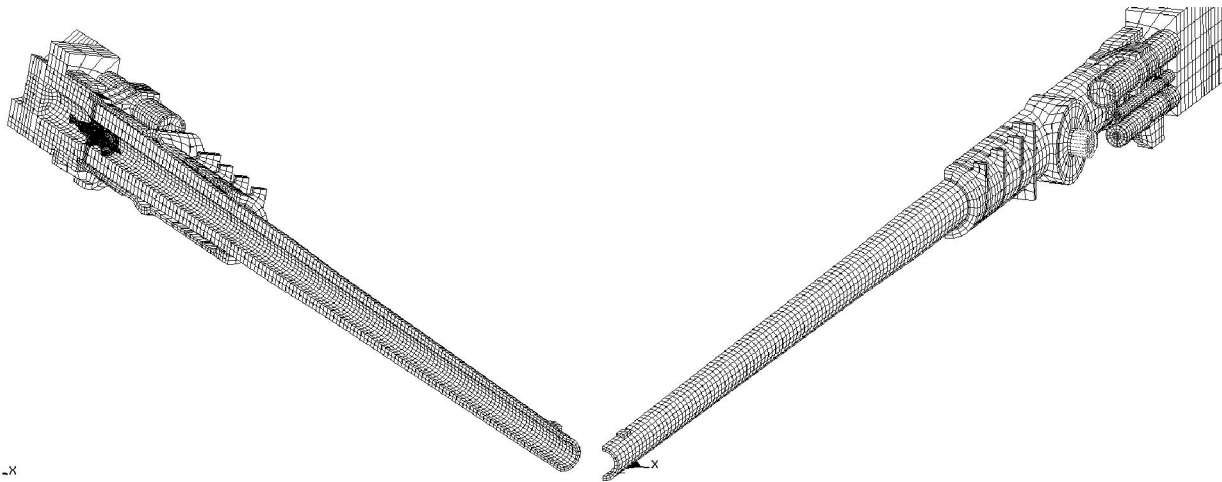

Figure 7 : Views of the model

Contacts

The model contains numerous slide surfaces, to manage all the contacts occurring during the firing event as realistically as possible.

A slide surface is set between the barrel and the cradle to allow the recoil.

The projectile-barrel inner wall interface is managed by slide surfaces between the obturator and the tube, and the bore rider and the gun. Slide surfaces are also set between the petals of the sabot, and as we said formerly, between the petals and the grooves of the penetrator.

The last interface lies between the obturator and the bulkhead of the sabot. The actual configuration is very close of a sliding contact with voids, as the obturator is moulded on the bulkhead. Unfortunately, the geometry of the interface, combined with the large stiffness difference between the obturator polyamide and the sabot aluminium seems to be problematic for the code, as the various attempts we made led to numerical errors, whatever the slide logic. The best compromise to manage this interface is to use of a tied interface, which allows using different mesh densities on both sides of the interface.

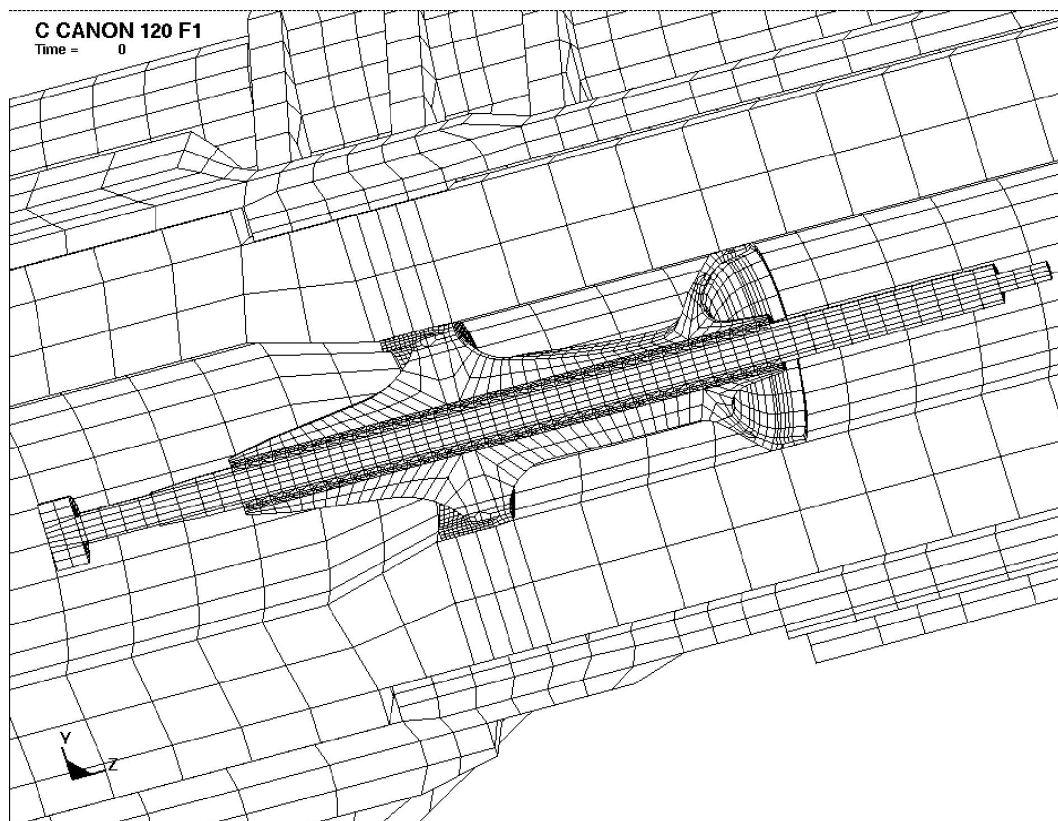

Figure 8: Close-up of the projectile mesh, showing the details of the rod-sabot interface, and the obturator

Boundary conditions

As only one half of the structure was modelled, all the solid parts, as the barrel, the breech, the cradle and the bearings, the penetrator, the fins, the windshield simulant and the obturator are constrained by a symmetry condition. So is the half sabot petal. The full sabot petal has one side in contact with the half petal, and one side coincident with the symmetry plane. But as this side corresponds actually to a petal-petal interface, the face is constrained by a stonewall, which forbids displacements through the symmetry plane, but allows displacements in the other direction.

The last boundary condition simulates the attachment of the gun to the mounting. It uses translational restraints in the three directions of the trunnions pins, while the X-axis rotation is still permitted.

Loadings

The main load applied on the system is the pressure generated by the combustion of the propellant. According to the location where this pressure is applied, the load curves vary. This is due to the fact a pressure gradient lies along the barrel, between the breech and the projectile. The breech pressure, which we can consider as uniformly applied on the chamber walls, is given by experimental measurements made during the firings. The base pressure, applied on the rear part of the projectile comes from the velocity versus time curve measured in-bore by the radar. This velocity is differentiated to yield the axial acceleration, which directly gives the pressure.

The pressure gradient along the barrel wall between the breech and the projectile is considered, at a given time, as a linear function of the distance from the breech. Thus, specific pressure curves are created for each barrel location where the pressure is applied.

The influence of gravity during the dynamic phase of the event is neglected. Its influence on the static deflection of the system is addressed by the initialisation phase.

Materials

All the materials constituting the weapon are considered elastic. Thus the barrel, breech and cradle use elastic steel, and the bearings are made of bronze.

The fins and windshield simulant are also modelled with elastic material, while the sabot, the projectile and the obturator follow the elasto-plastic material model n° 24.

Calculation sequence.

The simulation is run in two steps: a static initialisation, whose purpose is to cope with gravity effects, and the dynamic phase, which is our interest focus.

Static initialisation.

The meshing of the system is made using estimated relative positioning of its different components. Then, in order to set all the sub-assemblies in their actual static location, an initialisation is made, applying gravity to the whole structure. As when the study began, the LS-Dyna 3D implicit module did not exist, this initialisation uses LS-Nike 3D. Some adjustments are necessary to make the model compatible with the software, and to improve convergence. Thus, all materials are considered linear and all the nodes lying on the symmetry plane are constrained by a symmetry condition. As the elevation gear is not modelled, and the gun, with the projectile loaded, shows a very slight unbalancement torque, it is necessary to prevent the trunnions rotation to avoid rigid motion. So, a translation restraint in Y and Z is added on the whole external face of the trunnions pin.

Still to prevent rigid motions, one node on the breech and on the tail of the projectile are constrained in Z.

In order to improve convergence, a dynamic analysis is performed, until the barrel tip movement is stabilised. Fifteen iterations are typically necessary to obtain stabilisation. The tip of the barrel drops about 2.6 millimetres, and the breech, several tenth of millimetre.

Dynamic calculation.

The deformed geometry of the whole structure is then inserted in the LS-Dyna input file. The calculation is then run normally. It takes about fifteen CPU hours on a SGI O2 R10000 workstation.

Comparison with experiment and SIMBAD simulations.

The first task to perform when a new model is built is the validation, by comparison with experimental data. In our case, the data we had to compare our results with were mainly the displacement of the barrel, measured by the Kaman sensors, the recoil length at the projectile exit and the muzzle time of the projectile.

The last two parameters were in very good accordance with the experiment, with accuracy in the 1% order of magnitude. In fact, those parameters only validate the time integration of the load curves describing the pressure applied on the projectile and the barrel. We can thus check that the load curves are correct.

The most relevant validation of the model deals with the Kaman time-curves. The comparison with experimental result allows here to make a statement on the ability of the model to manage the numerous interactions between its different components.

The graphs below show the envelope of the experimental measurements, in thin black lines, the result given by the LS-Dyna 3D model in thick solid line, and the results yielded by the SIMBAD model, in thick dotted line.

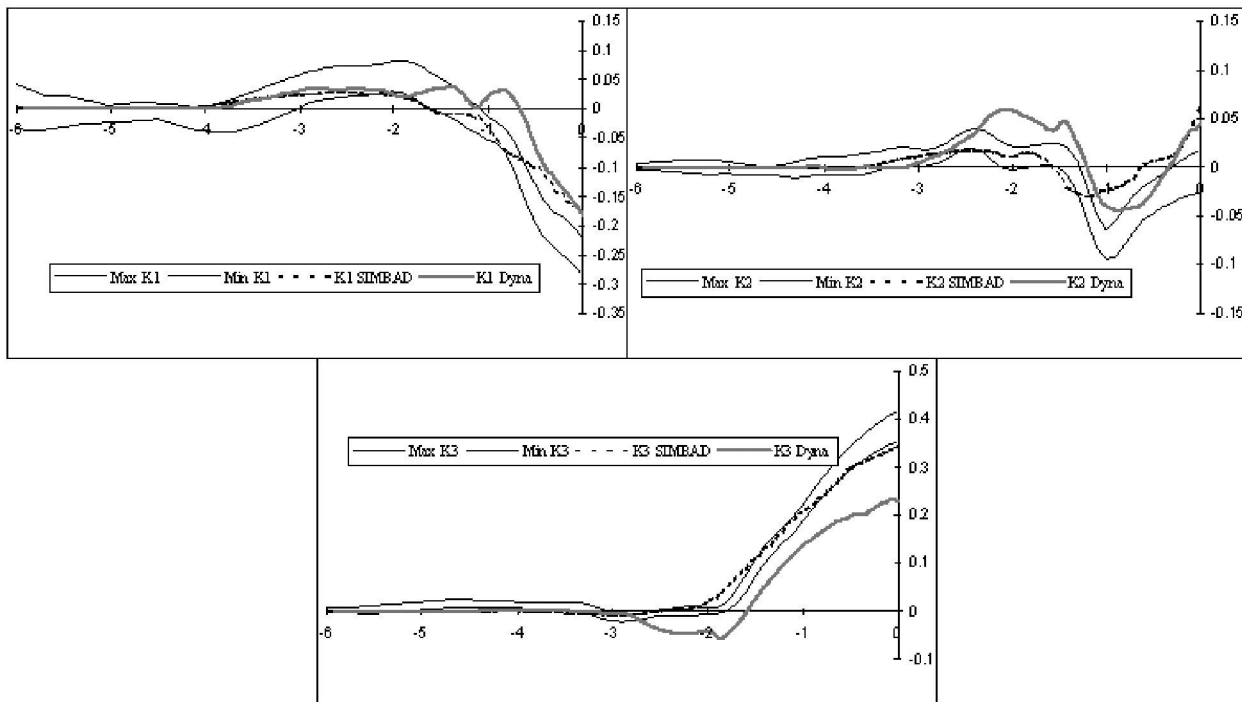

Figure 9: Comparison between tests and simulation.

The SIMBAD model used here is a calibrated model, where all significant parameters such as contact stiffness and damping were tuned to get the best possible response. The LS-Dyna model was not calibrated at all. The relative stiffness on the master and slave side of the barrel-obturator interface was tuned in order to allow the calculation to terminate normally.

One can notice that the agreement with experiment is good. The global trend of the motion is given, but when the experimental curves show an elbow, one can observe a slight delay in the response of the Dyna model, resulting in a shift of the curve. Nevertheless, the slopes are quite correct. The SIMBAD model follows better the curve elbows, but shows a damped response, resulting in softer slopes, especially for K1 and K2.

There is certainly room for improvement in the accuracy of the LS-Dyna model, but in a first stage, we considered it satisfactory enough to go further on the study of projectiles behaviour. The idea was to get a first impression on the abilities of this tool, before entering a tuning campaign to represent more faithfully the actual firing event.

Examples of possible uses of this model.

The information we can gain from such a model is really extensive. It covers a range from very global information on the system dynamic response to certain parameters, to very local aspects, like the dynamics of contact between the barrel and the bore-rider. One example is described hereafter.

Comparison of vibrating behaviour of different APFSDS.

For this study, we compared the motions of several points of the rods of different projectiles. Those projectiles were:

- The baseline APFSDS which was fired during the tests, and whose model is described above,
- The same projectile, without slide surfaces between the rod and the sabot, and between the sabot petals. This model was set to demonstrate that the realistic modelling of the baseline gives more degrees of freedom to the rod to move inside the sabot,
- The baseline projectile, with a depleted uranium penetrator, which is a purely hypothetical and virtual projectile, whose purpose is to investigate the differences of behaviour due to the difference of mechanical properties between the two most commonly used materials for penetrators.

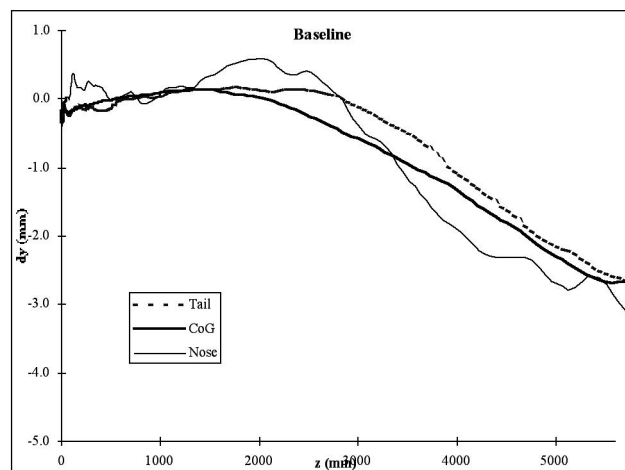

Figure 10: Vertical motion of the tied baseline rod tail, CoG and nose, in mm.

This kind of study is easy to perform, as the geometry of the projectile does not change. The sole alterations of the model are the slide surfaces that become tied in one case, or the mechanical properties of materials in the last one.

The following curves show, for the three cases, the displacement of the tail, the centre of gravity and the nose of the rod.

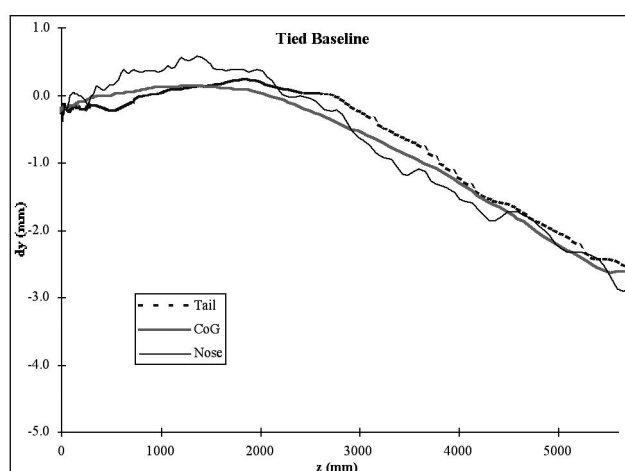

Figure 11 : Vertical motion of the baseline rod tail, CoG and nose, in mm.

The vertical displacements of the three nodes are given as a function of the location of the rear face of the obturator. When the latter has travelled 5600 mm, it exits the barrel, the seal breaks and the in-bore phase of the projectile, also known as the interior ballistics phase is said completed. Those graphs cover the whole interior ballistics phase. One can notice that unsurprisingly, the CoG motion is relatively similar between the three cases. This is due to the fact that it is located slightly in front of the bulkhead base, which follows very closely the barrel geometry, because the obturator is forced between them, with no clearances. In addition, the region aft the bulkhead, as well as its neighbourhood are compressed by the pressure, and close the clearance between rod and sabot. Then the CoG follows closely the barrel shape.

Differences appear on the tail and nose displacements.

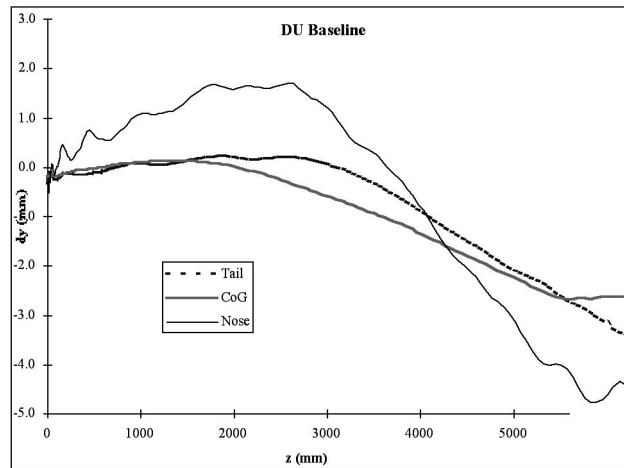

Figure 12: Vertical motion of the DU baseline rod tail, CoG and nose, in mm.

While the CoG does not drop, the projectile is in the first two meters of the barrel, and its velocity is not very high. So, whipping movements of the end of the rod are not very important. Once the CoG drops, at about 2000 mm, the velocity increases as well as vertical acceleration. Then, the conditions to magnify the whipping motion are set, and we can notice very different responses to those conditions. The nose and tail follow very closely the CoG trajectory on the “tied baseline”, with no sliding surfaces. This is because the central part of the rod, welded to the sabot is very rigid, and moves rigidly with the CoG and the free ends aft and front of the sabot are not long enough to have relative large displacements.

If this situation is relatively similar on the aft part of the baseline, where the sabot, under the gas pressure, closes its clearance with the penetrator, it is very different on the front part, where the rod is less constrained, because of the static clearance, which tends to increase under acceleration, when the bore-rider bends backwards, and the sabot itself opens. Figure 13 shows this phenomenon.

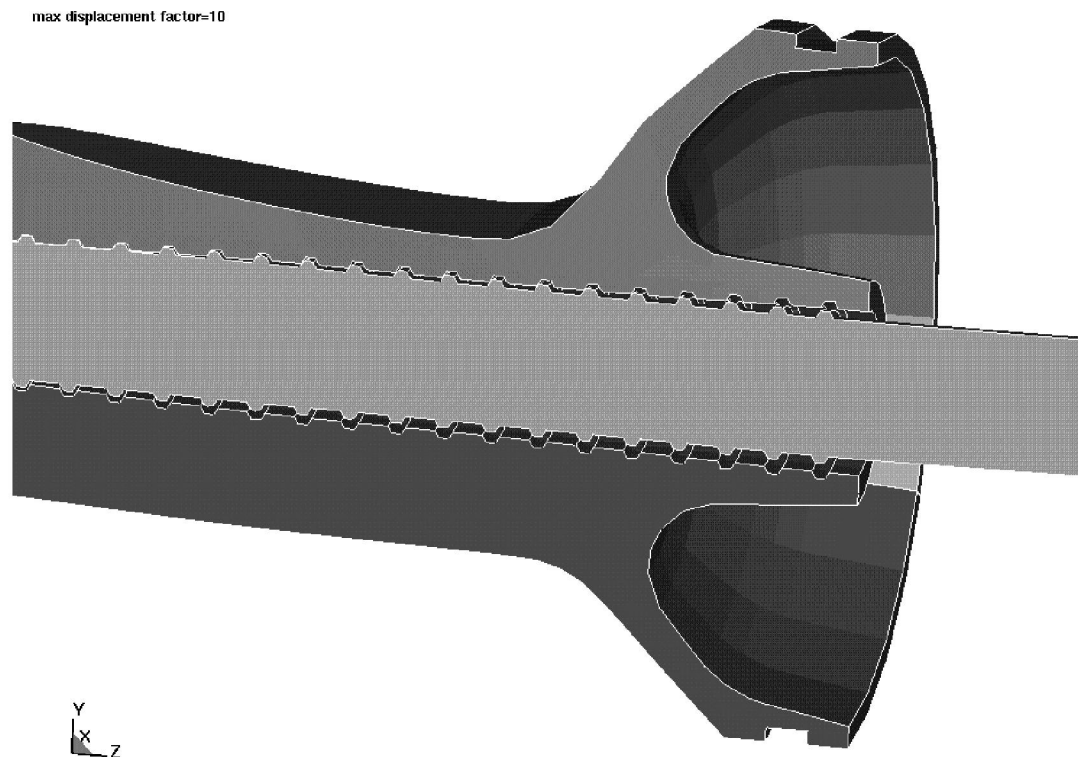

Figure 13: Detail showing the opening of the sabot under acceleration.

The last projectile is a virtual one, which uses a depleted uranium penetrator, whose elastic modulus is half the tungsten, and whose density is 6% higher.

One can notice that the front part of the penetrator moves even more than the baseline's, because of the less stiff and heavier material, which is more sensible to transverse accelerations. The motion of the tail part, for the same reason than above, can be compared with the two other projectiles.

Thanks to the model, it is relatively easy to tune the sabot geometry in order to reduce the magnitude of the nose vertical motion.

Conclusion.

The model presented here shows that current numerical techniques, associated with reasonably powerful workstations are a very efficient tool for the expertise of highly transient phenomena, for whose direct measurement is not possible. LS-Dyna offers good flexibility, calculation speed, and robust numerical scheme, which make the set-up of such a model easy. The only real problem encountered during this study was the sabot-obturator interface.

Thus, the in-bore travel response is now a task that will more and more be included in the Work Breakdown Structures of future APFSDS concept studies or developments. Nevertheless, some work remain to do to improve the comparison of experimental and simulated barrel displacements, to solve the barrel-obturator interface problem, and to integrate the solving method, by using the LS-Dyna 3D implicit solver for the initialisation, and then, automatically switch to the explicit calculation.

References

- [1] : Flexible Projectile Modelling Using the Little Rascal Gun Dynamics Program.; T.F. Erline, M.D. Kregel.; 6th Symposium on gun ballistics, 05/1990
- [2] Modelling Gun Dynamics with 3D Beam Elements; D.A. Hopkins; 6th Symposium on gun ballistics, 05/1990
- [3] The need for an integrated mathematical model of shot motion, from breech to target, for tank guns; S.E. Powell; 13th International symposium on Ballistics, Stockholm; 06/1992.
- [4] : The in-bore bending dynamics of long rod projectiles; D.N. Bulman; 13th International symposium on Ballistics, Stockholm; 06/1992.
- [5] : Axially Accelerated Saboted Rods Subjected to Lateral Forces; D.A. Rabern; LANL report LA-11494-MS; 03/1989.
- [6] : Techniques for Modelling Bullet Exit Conditions Predicted by Transient Finite Element Models; S. Wilkerson, D. Hopkins, B. Held; 8th Symposium on gun dynamics; 05/1996.
- [7] : Analysis of a Balanced Breech System for the M1A1 Main Gun System Using Finite Element Techniques; S. Wilkerson D.Hopkins; ARL Report ARL-TR-608; 11/1994.