

# **CRASHWORTHINESS ANALYSIS OF A LOCK GATE IMPACTED BY THREE DIFFERENT RIVER SHIPS**

*Hervé Le Sourné\* - Jean-Claude Rodet\*\* - Stéphane Paboeuf\* - Guy Babaud\**  
*\* French Shipbuilding Research Institute- Nantes - h.lesourne@ircn.asso.fr*  
*\*\* ECMT - Lyon - jc.rodet@wanadoo.fr*

## INTRODUCTION

This paper presents a study of the crashworthiness of the Pierre Bénite lock gate using a FEM approach. This gate situated in the Rhône river (south of Lyon) is collided by three different river ships :

- a 6000 DWT convoy of barges with an initial velocity of 1m/s,
- 3500 DWT carrier Rhône-Liner with an initial velocity of 1m/s,
- a 2200 DWT passenger vessel with initial velocities of 1m/s and 2m/s.

An analytical elastic analysis of the crashworthiness of a lock gate was carried out by J.C Rodet for the «Compagnie Nationale du Rhône». This analysis showed that :

- the kinetic energy of a river ship which impacts a lock gate with a velocity of 1m/s is not entirely dissipated by the elastic energy of the lock gate,
- the lock gate elastic response may result in dangerous reaction forces at the supporting chains,
- empirical or analytical methods [2] generally used to determine the impact forces and resulting indentations of struck ship hulls may be applied to the lock gate but they have to be validated by a non-linear finite element analysis.

An overview of the elastic analysis is presented in section 2 below. As we found that an elastic analysis was insufficient to quantify the damage, we decided to conduct a numerical analysis (section 3).

## ANALYTICAL ELASTIC ANALYSIS

When a rigid ship bow strikes a lock gate with a kinetic energy ( $E$ ), its structure will be deformed. It is worthwhile to know the amount of deformation energy ( $W$ ) the gate can absorb without damage (i.e only with elastic deformation) in order to compare it with  $E$ . This has been achieved by a simplified analytical method for a steel plane gate (area :  $12.7 \times 8.8 \text{ m}^2$ , yield stress  $21.6 \text{ daN/mm}^2$ ).

The structure of a lock gate is rather similar to the structured design of a ship hull :

- one or two shell plates stiffened by longitudinals
- vertical transverse webs
- horizontal side stringers

The Pierre Bénite gate is modeled as a single plate of equivalent thickness ( $e$ ) subjected to an hydrostatic pressure and a quasi-static point load ( $F$ ) exerted at the middle of its upper free bound by the colliding bow (see figure 1).

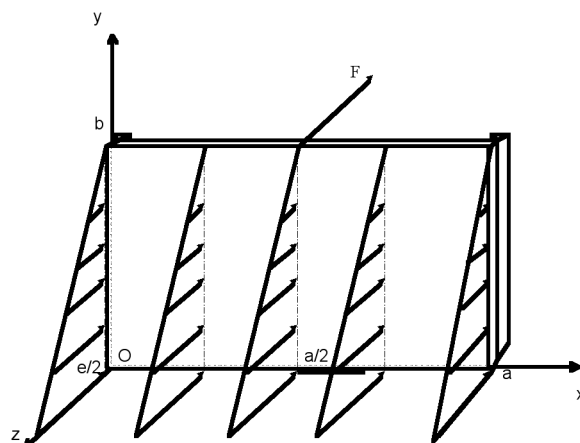

Figure 1 : Sketch of the lock gate modeled as a plate of equivalent thickness  $e$

Only bending stresses are assumed to appear in the plate. The boundary conditions are the following :

- the lateral edges are simply supported,
- the lower edge is free under the sole hydrostatic load and clamped when the concentrated load is applied.

By considering only the hydrostatic load in the first stage, the equivalent thickness is calculated as a function of the security coefficient  $n$ . This coefficient is defined as the ratio between the actual maximum combined stress in the lock gate and the yield stress. The quasi-static concentrated load  $F$  is then derived by writing the equality of the calculated maximum Von Mises stress in the plate and the yield stress when the plate is subjected to both loads. Finally, the bending elastic deformation energy is derived from  $F$ .

Figure 2 presents the elastic energy, the deflection  $f$  at the load point location and the equivalent thickness  $e$ , versus the security coefficient  $n$ .

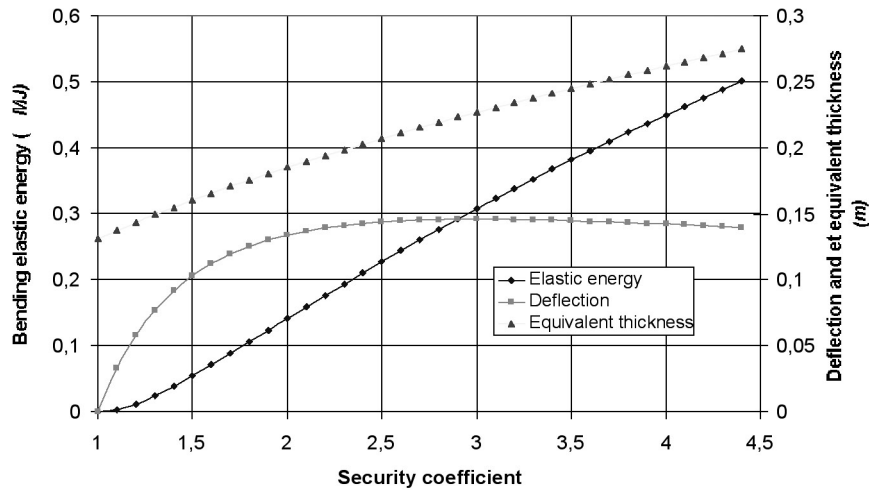

Figure 2 : Variations of elastic energy, deflection and equivalent thickness versus security coefficient

For its most usual value  $n = 2.5$  chosen by lock gate builders and recommended by the DIN 19704 standard we get :  $e = 0.21$  m ,  $f = 0.15$  m and  $W = 0.22$  MJ. This latter value is much lower than the kinetic energy of ships for an impact velocity of 1 m/s which is used in this study.

Table 1 presents this energy for four different ships.

	Ballast displacement $m_0$ (tons)	Laden displacement $m_l$ (tons)	Kinetic energy at $1\text{ms}^{-1}$ $E(MJ) = 0.55(m_0+m_l)I^2$
Rhôdanian Automotor	400	600	$0.22 < E < 0.55$
Carrier Rhône-Liner	400	3000	$0.22 < E < 1.87$
passenger vessel	700	1300	$0.39 < E < 1.1$
Convoy of two barges	$2 \times 406 + 500$	$2 \times 2731$	$0.70 < E < 3.7$

Table 1 : Kinetic energies of different ships on the Rhône river

## ELASTO PLASTIC FINITE ELEMENT ANALYSIS

### Mesh size effect analysis

It is well known that a finite element crash analysis is very sensitive to the size of the mesh. The first step of our analysis then consisted in impacting a bulb finite element model with an initial velocity of 6 m/s against a rigid wall. The bulb was modeled by using three different size meshes : 10 cm, 20 cm and 40 cm.

Figure 3 presents a comparison of the impact forces obtained by the three different meshes. The fourth curve corresponds to a bulb whose floors have been stiffened by beam elements in order to represent a more realistic bulb. The deformed models for the 40 cm and 10 cm meshes are presented in figure 4.

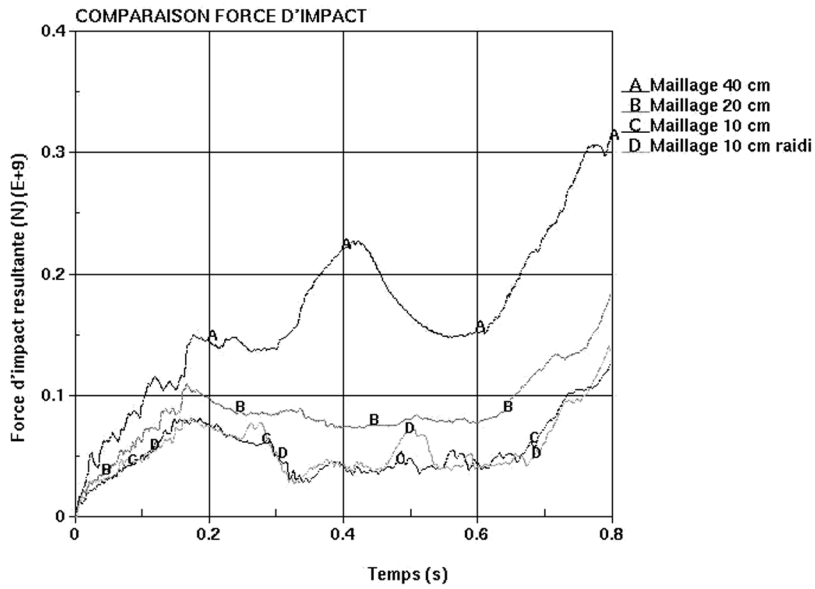

Figure 3 : comparison of impact forces

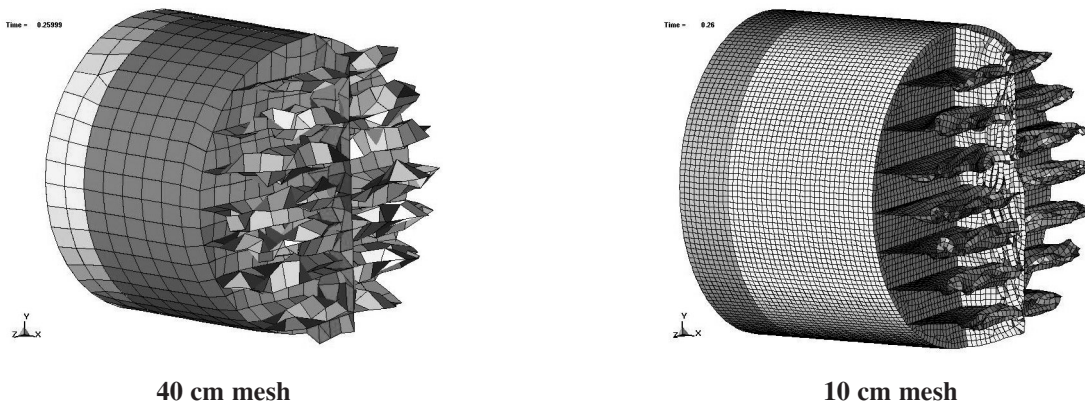

Figure 4 : deformed models at t=0.26s.

In the longitudinal sections presented below, a comparison of the deformed floors shows that the folding process of the floors is better represented by the fine mesh. The coarse mesh is too stiff and does not reproduce the buckling of the floors.

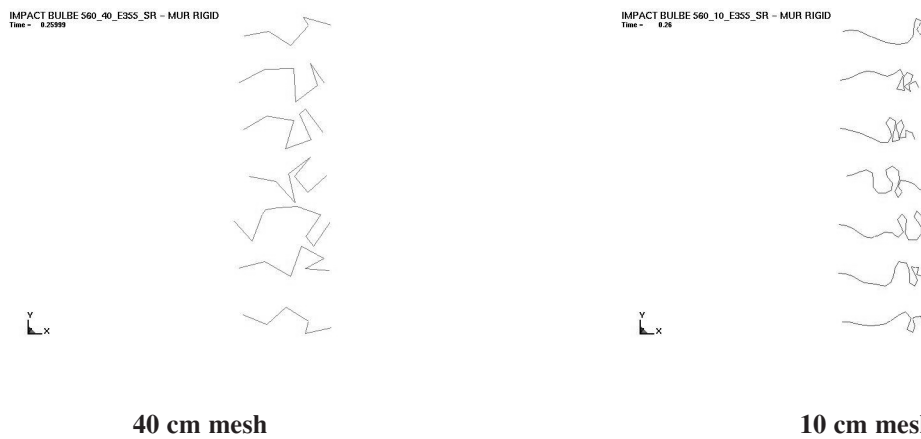

figure 5 : section view of the deformed floors

In order to converge to the best mesh size, a 3.5 cm mesh was also used and the FEM computation gave the same impact force as the 10 cm mesh one.

### Description of the structures

Driven by rollers, the gate is lifted out of its seating by two chains hooked on each side and moved by a motor. Its main characteristics are the following :

- length : 12,7 m
- height : 7,05 m
- mass : 45 tons
- material : mild steel

Table 2 lists the main characteristics of the three striking ships.

	<i>Convoy of barges</i>	<i>Carrier Rhône-Liner</i>	<i>passenger vessel</i>
Length	170 m	79 m	118 m
Breadth	11,4 m	10,9 m	11 m
Laden displacement	6000 t	3500 t	2210 t
Draught	3,5 m	3,3 m	2,2 m
Material	mild steel	mild steel	mild steel

**Table 2 : main characteristics of the colliding river ships**

Collision scenarios are presented in the next figures :

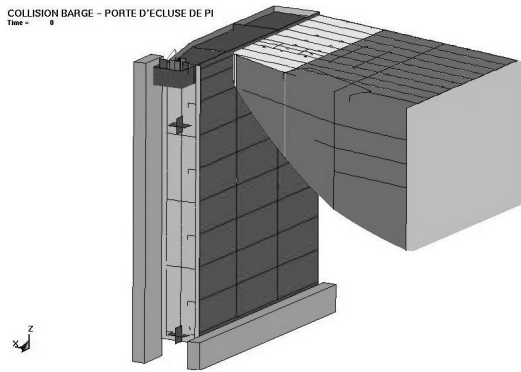

**Figure 6.a : impact of a convoy of barges -  $v_0=1\text{m/s}$**

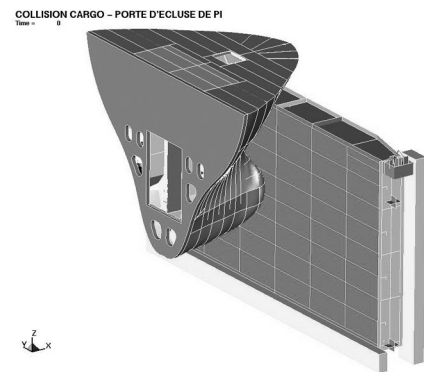

**Figure 6.b : carrier impact -  $v_0=1\text{m/s}$**

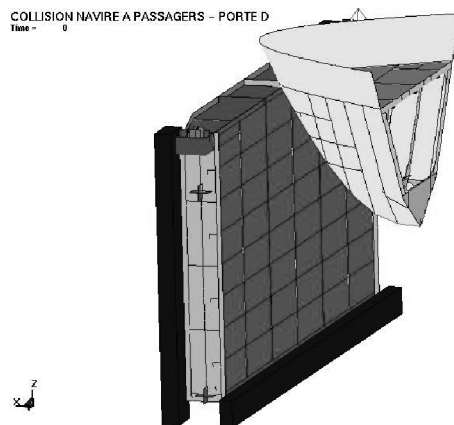

**Figure 6.c : passenger vessel impact with  $v_0 = 1\text{m/s}$  and  $v_o = 2\text{m/s}$**

## Modeling

The lock gate :

The finite element meshes of the gate and of the ships were created using Ideas Master Series™ as a preprocessor of LS-DYNA™. The gate was meshed with 34000 Belytschko-Lin-Tsai shell elements [3] using three Gauss integration points through the thickness. The medium size of a shell element was about 8 cm near the impact zone, 10 cm at mid-gate and 12 cm at the bottom.

The hauling system was represented by three rigid beams on each side. The FEM gate model is shown in figure 7.a. The gate is simply supported in all directions (see figure 7.b). In the impact scenario of a convoy of barges, the problem is supposed to be symmetrical, so a plane of symmetry was defined in the middle of the gate. The hydrostatic pressure in the lower part of the gate was not taken into account.

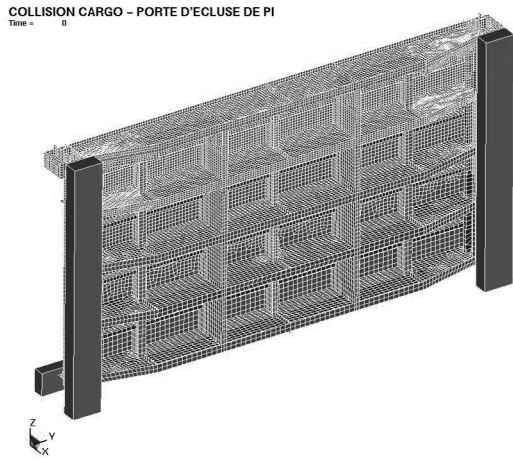

Figure 7.a : lock gate mesh

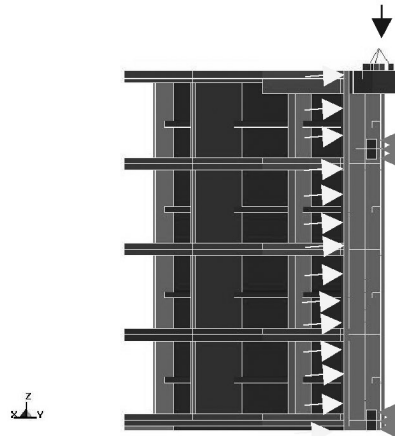

Figure 7.b : lock gate boundary conditions

The river ships :

Only the deformable bows of the river ships were modeled. The mesh size was about 8 cm near the impact zone, 10 cm in the middle of the model and 12 cm in the back side. A rigid body attached to the back side of the deformable bow represents the rest of the ship. This rigid body is associated with a center of gravity and an inertia matrix. The FEM model of the carrier Rhône-liner is presented in figures 8.a and 8.b.

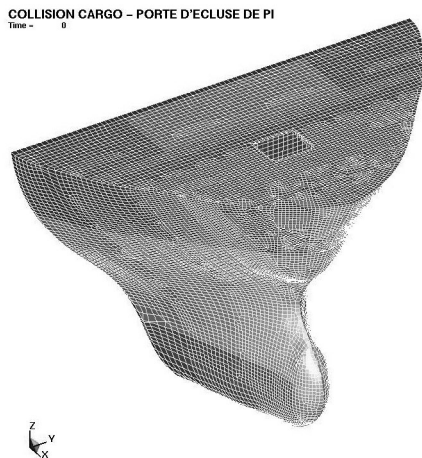

Figure 8.a : cargo hull mesh

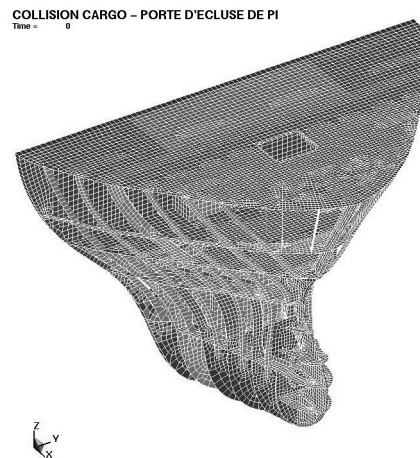

Figure 8.b : cargo stiffening mesh

The concrete frame of the lock is modeled by a clamped rigid body (see figures 6a, 6b and 6c).

## Material and contact interfaces description

The material used for the lock gate and for the ships was the A48 mild steel. The elasto-plastic material law is described by a stress-strain curve obtained by a tensile test. Also, failure based on an effective plastic strain is taken into account.

In the material formulation used in this study (MAT\_PIECEWISE\_LINEAR\_PLASTICITY), the failure process is modeled by erosive elements. When the effective plastic strain of an element reaches a critical strain value, this element is deleted from the calculation.

Three penalty contact interfaces were defined. The first between the ship hull and the gate plating, the second between the different components of the gate (auto-contact) and the third between the different components of the ship (auto-contact).

## Some numerical results

Global energies obtained from the cargo-liner impact simulation are presented in figure 9.a. The cargo-liner kinetic energy is completely transformed into strain energy of the lock gate after 1.36 sec. The hourglass and friction energies remain small. The internal energies dissipated by the different components of the lock gate are shown in figure 9.b.

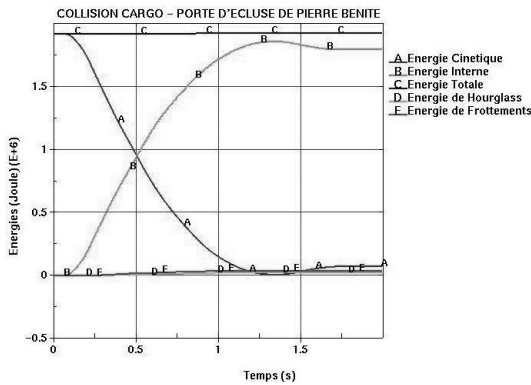

Figure 9.a : global energies

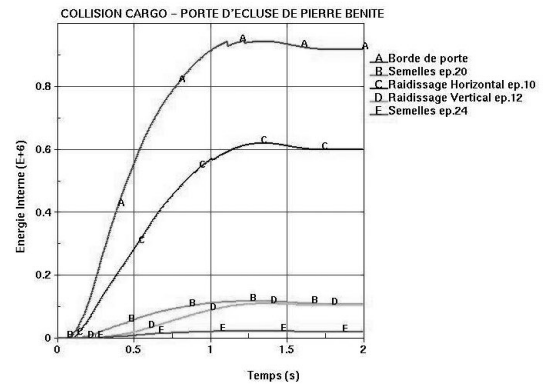

Figure 9.b : component energies

In figure 10, we can see that the vertical component  $F_z$  of the impact force is completely transmitted to the chains.

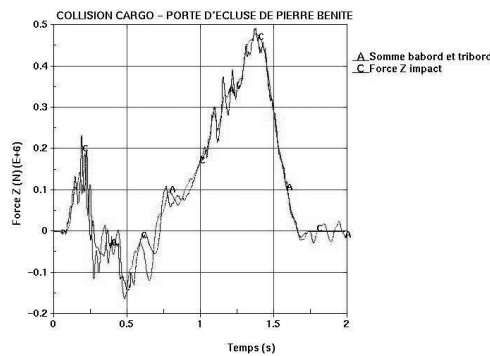
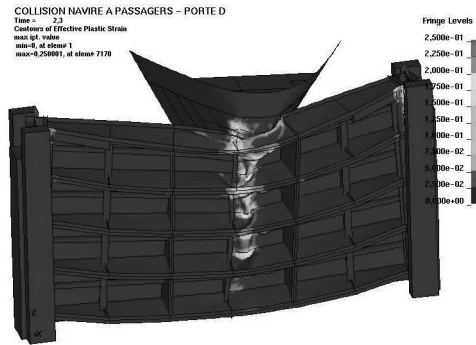

Figure 10 : impact force compared to the force transmitted to the chains



The next graphic presents a view of the effective plastic strains in the lock gate when it is impacted by the passenger vessel. Here, the vessel is intentionally shifted from of the center in order to simulate the worse impact case. Actually, this position is determined from the breadths of the vessel and of the lock, and leads to an impact located in the middle of the two vertical stiffeners.



**Figure 11 : effective plastic strains at t=2,3 sec**

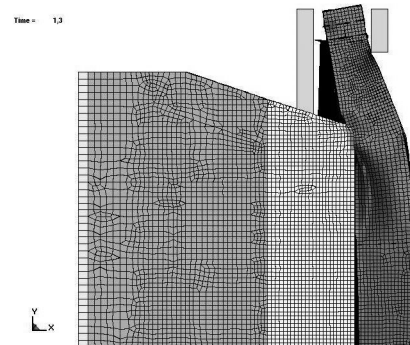

**Figure 12 : lock gate collided by the barge**

Defining a plan of symmetry as a boundary condition when this kind of bow collides in the center of the gate leads to non physical deformations. In fact, the condition of symmetry prevents the central vertical stiffener from folding correctly (the out of plane displacements are ignored). Thus it is more realistic to consider a collision with no symmetry.

On the other hand, in the case of the barge impact, the condition of symmetry can be applied because the lock gate deforms only near the external sides of the barge (see figure 12).

## CONCLUSION

The numerical simulations carried out with the explicit core code LS-DYNA allowed a better understanding of the crashworthiness of the Pierre Bénite lock gate when it is impacted by a river ship. The indentation of the lock gate and the forces acting on the supporting chains have been calculated for the three proposed scenarios. In the three simulated collisions, the ship bows only suffer little deformations. Therefore they could be modeled as a rigid body in an analytical formulation.

## BIBLIOGRAPHY

- [1] Rodet J.C. « Dispositifs de sécurité amont des écluses. Résistance aux chocs des portes. Rapport phase 1. Méthodologie » - Rapport CNR DI-OA 00-48, april 2000
- [2] Zhang S. « The mechanics of Ship Collisions » - Technical University of Denmark, Ph.D. Thesis - february 1999
- [3] Hallquist J. «LS-DYNA Theoretical Manual »