

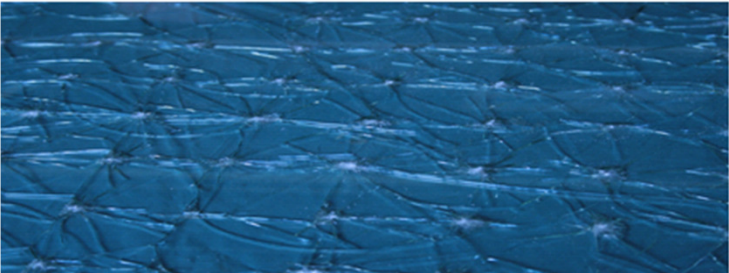

Mercedes-Benz



An Approach to capture the Ejection Mitigation Requirements of FMVSS 226 with Finite Element Simulations

André Haufe¹, George Dimitru¹, Andreas Hirth², Robert Kirchner³

¹ DYNAmore GmbH, 70565 Stuttgart, Germany

² Daimler AG, EP/SPV, 71059 Sindelfingen, Germany

³ Friedmann & Kirchner, 76865 Rohrbach, Germany



Experimental Investigation

Definition of test programme

- FMVSS226: Definition of impact loading on pre-damaged laminated side windows

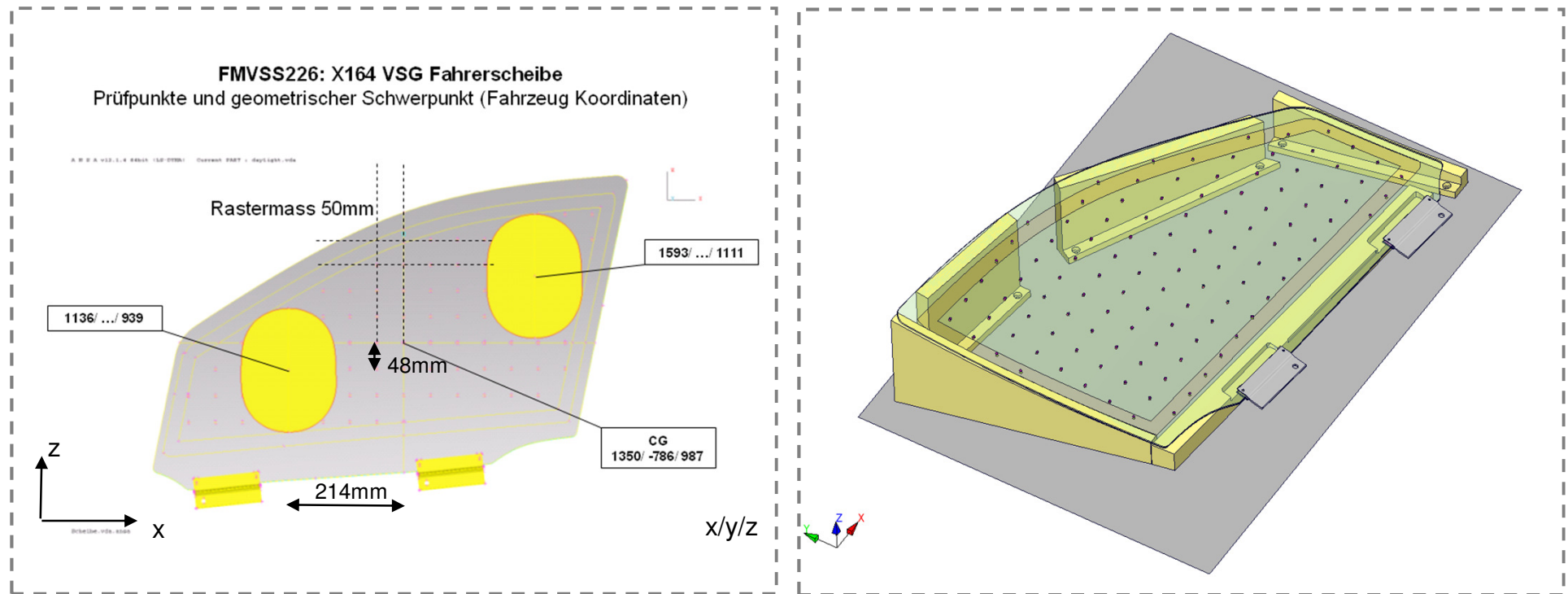

- Laboratory: Friedmann & Kirchner GmbH, Rohrbach, Germany
- Definition of boundary condition for test have been done by finite element studies (support system, impactor geometry, and velocity, degree of pre-damage)
- Definition of glass failure parameters and PVB behavior by small test coupons.

QS tests

- Pre-damaged laminated glass: pre-damaged on both sides by 50mm grid
- QS loading with a velocity of 500 mm/min

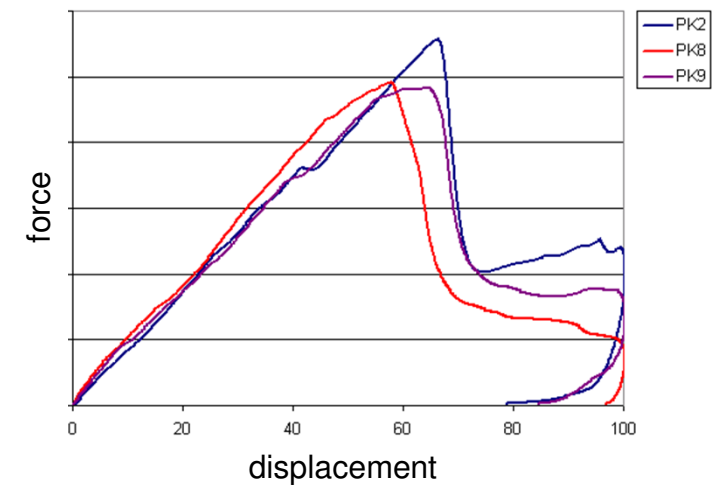
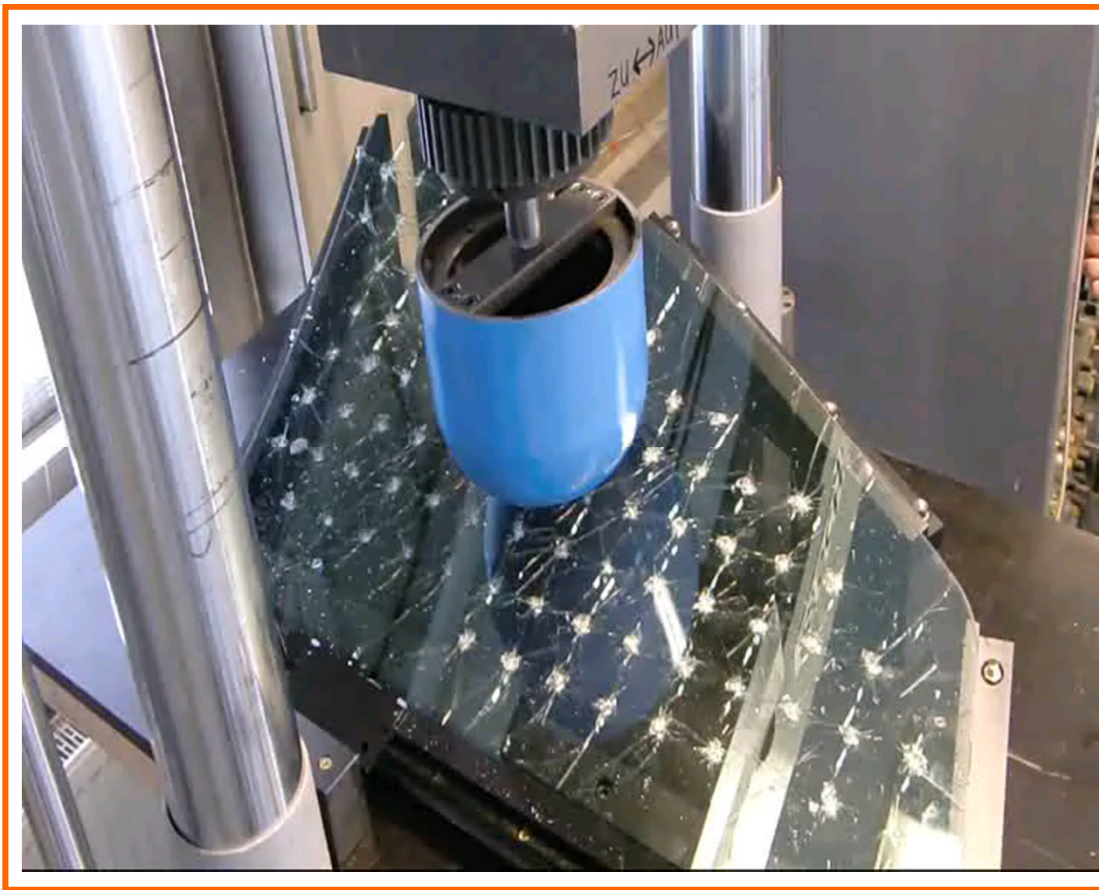
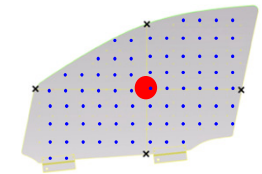

QS tests

- Pre-damaged laminated glass: pre-damaged on both sides by 100mm grid
- QS loading with a velocity of 500 mm/min

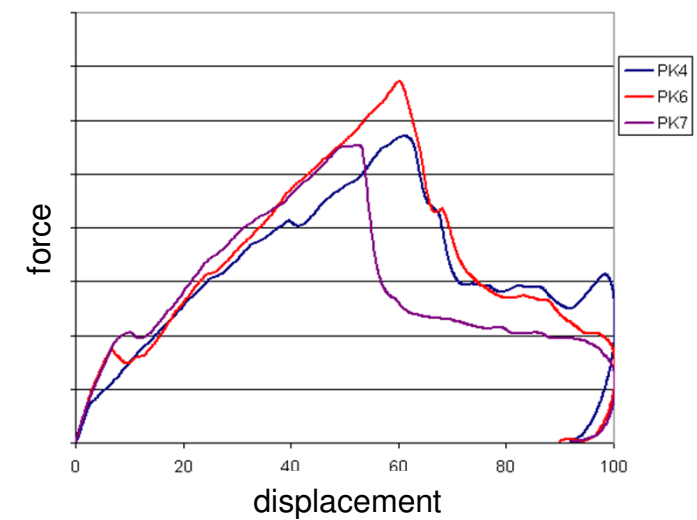
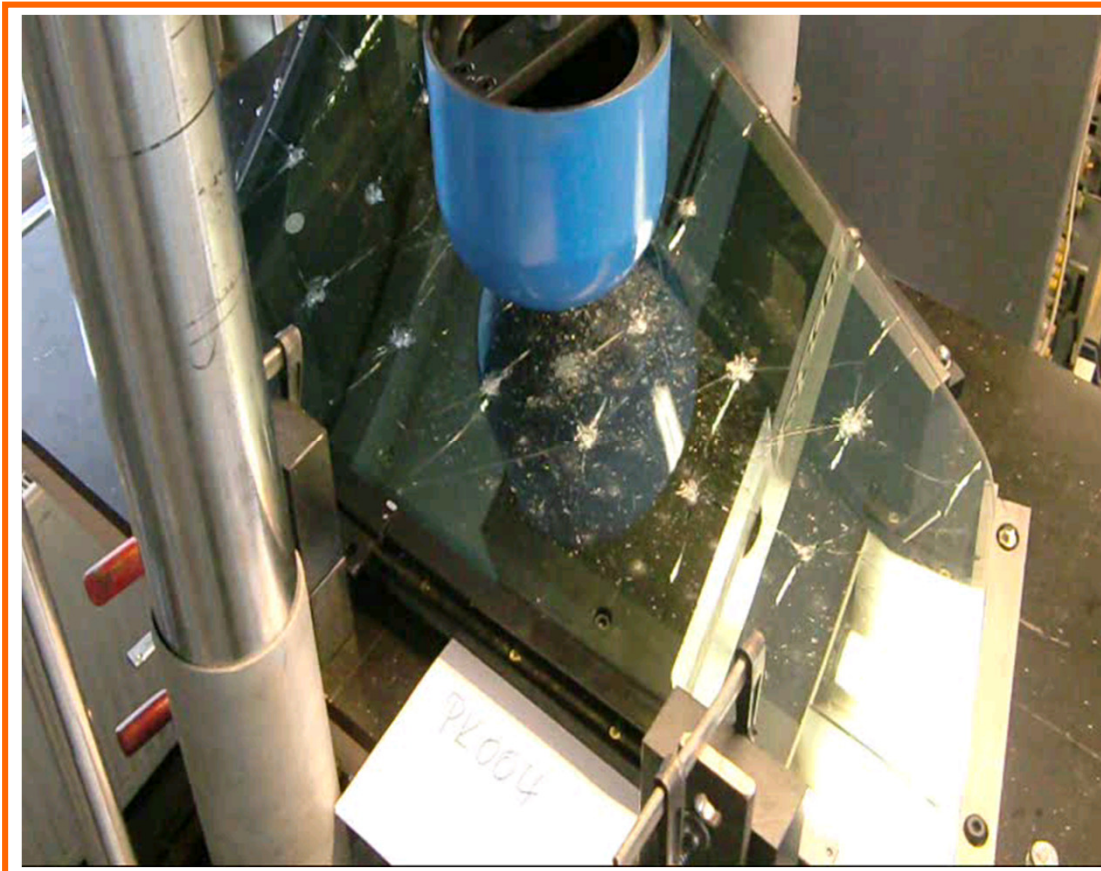
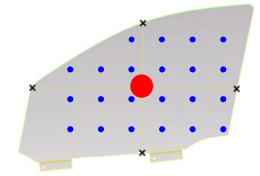

QS tests

- Undamaged laminated glass: impact in center point
- QS loading with a velocity of 500 mm/min

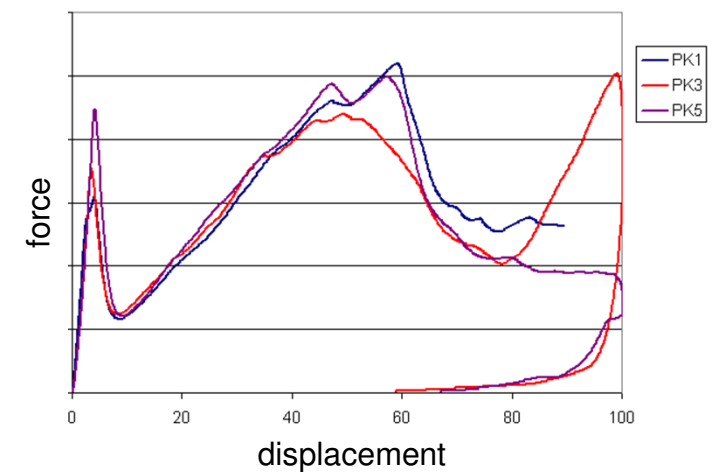
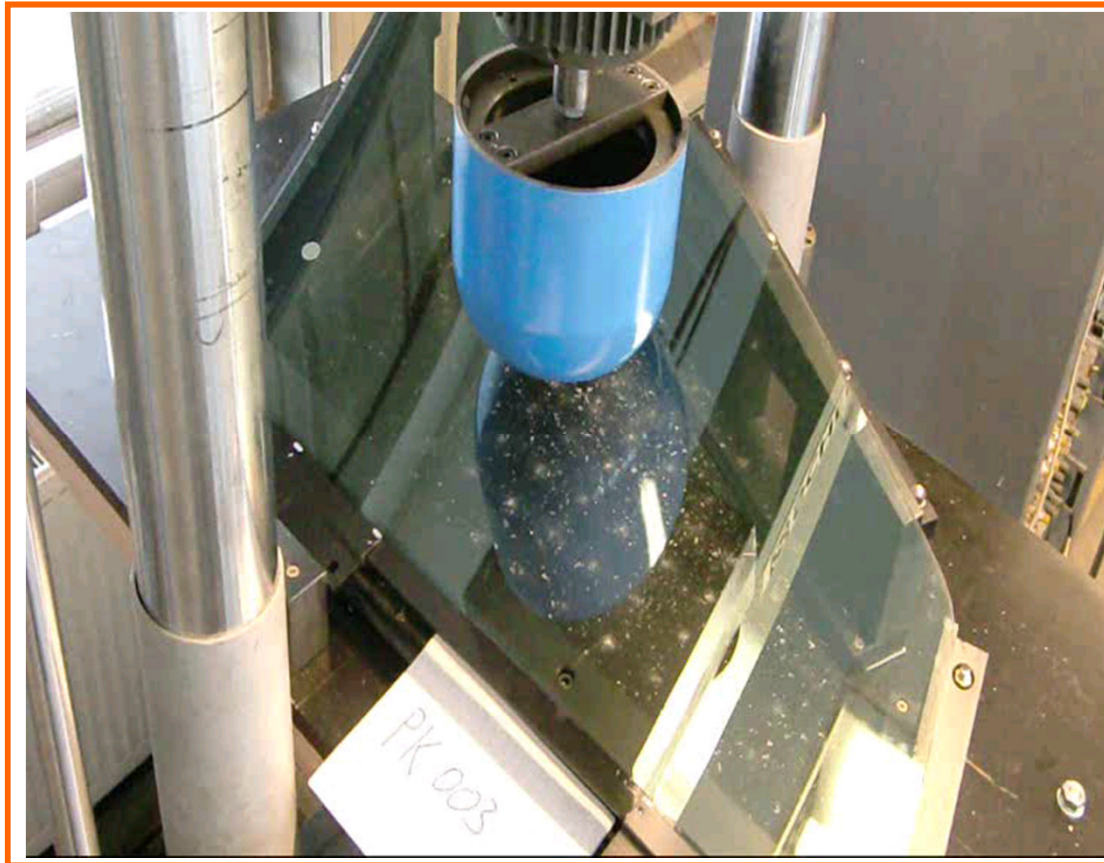
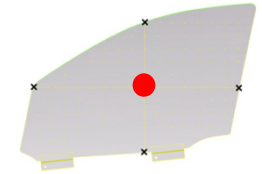

Dynamic test setup

- Predamaged laminated glass: predamaged on both sides by 50mm grid
- Dynamic loading by 5m/s

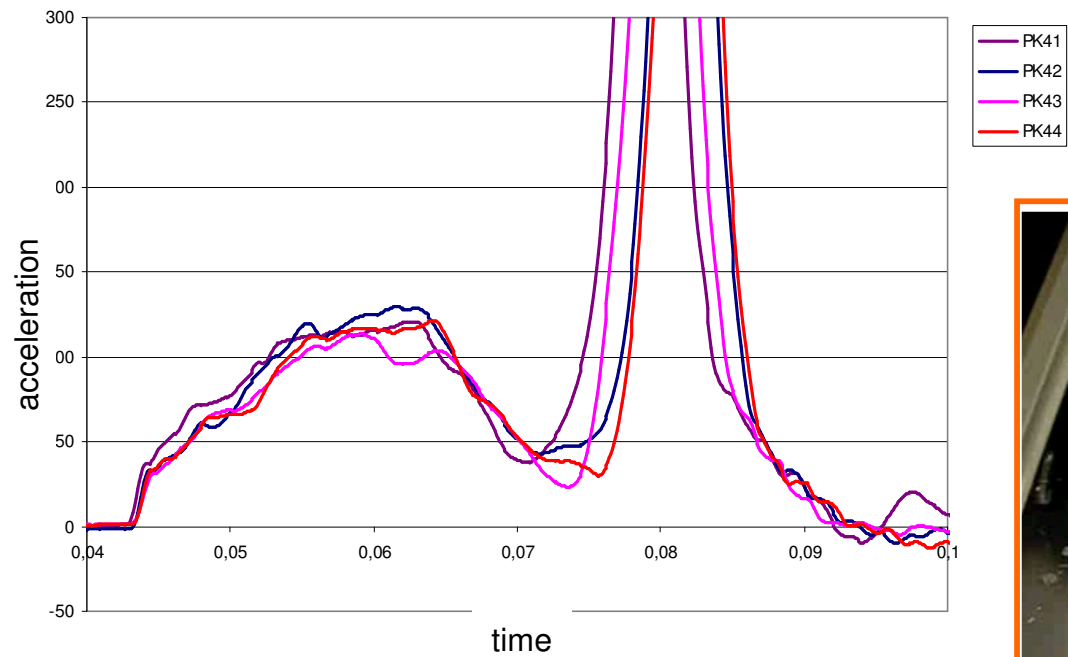
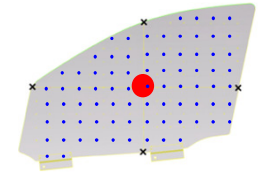

dynamic, $v = 5 \text{ m/s}$

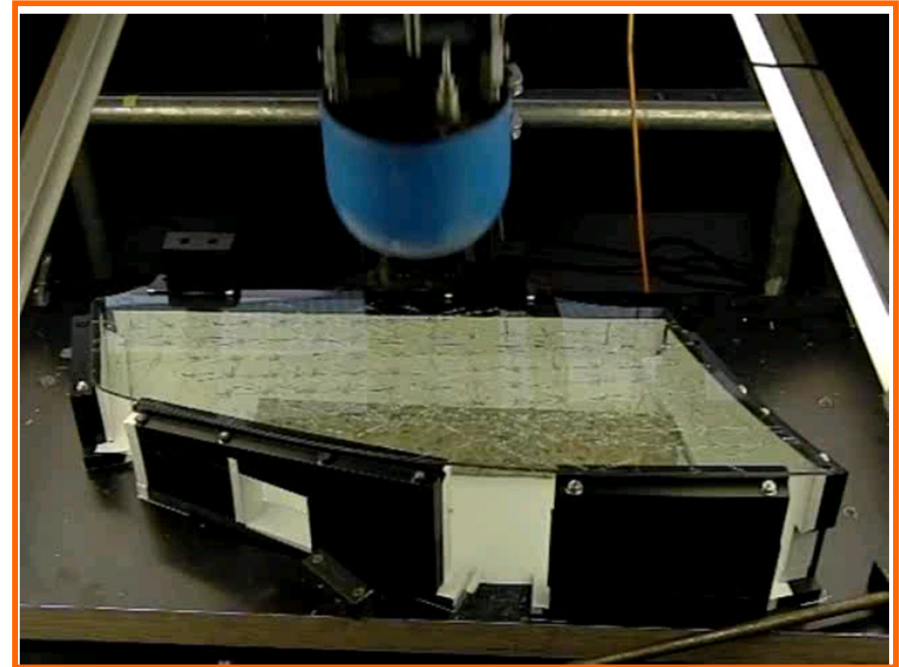

Dynamic test setup

- Predamaged laminated glass: predamaged on both sides by 100mm grid
- Dynamic loading by 5m/s

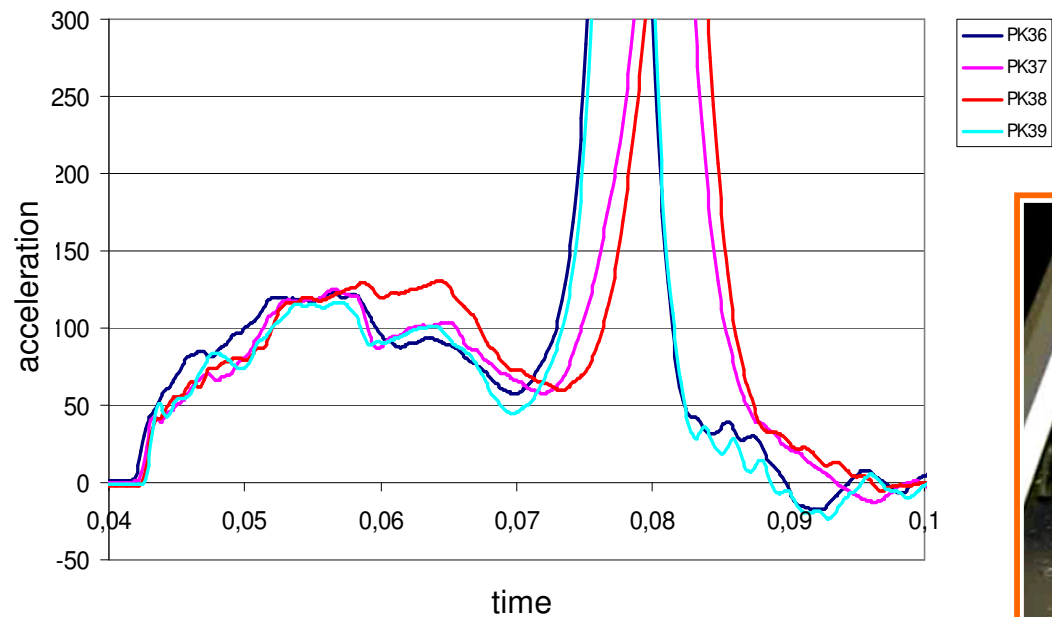
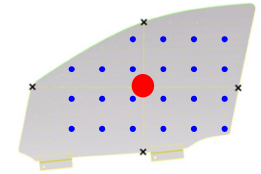

dynamic, $v= 5$ m/s

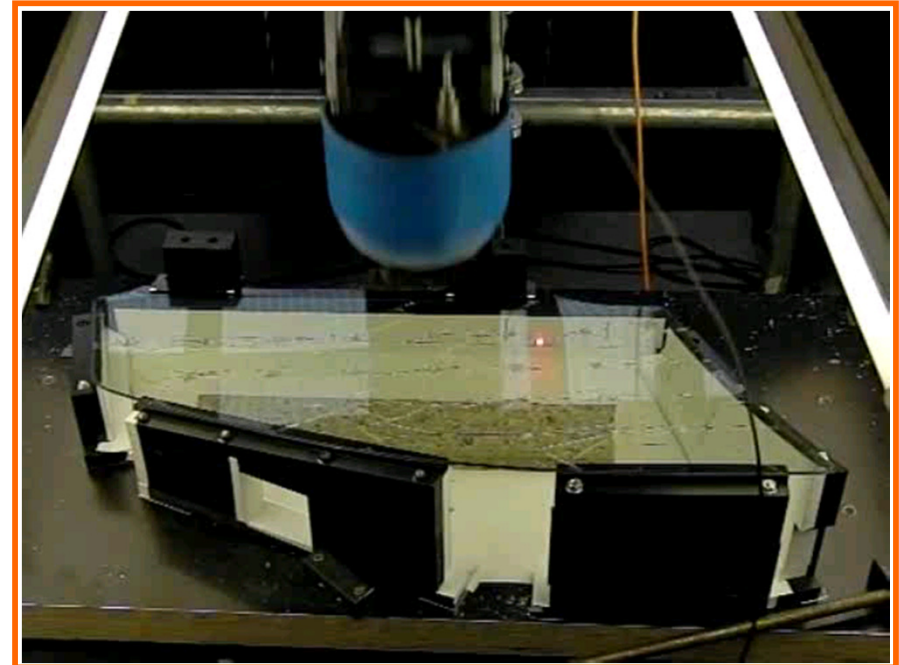

Dynamic tests

- Initially damaged glass (midpoint), impact of $v=5\text{m/s}$
- Loading midpoint

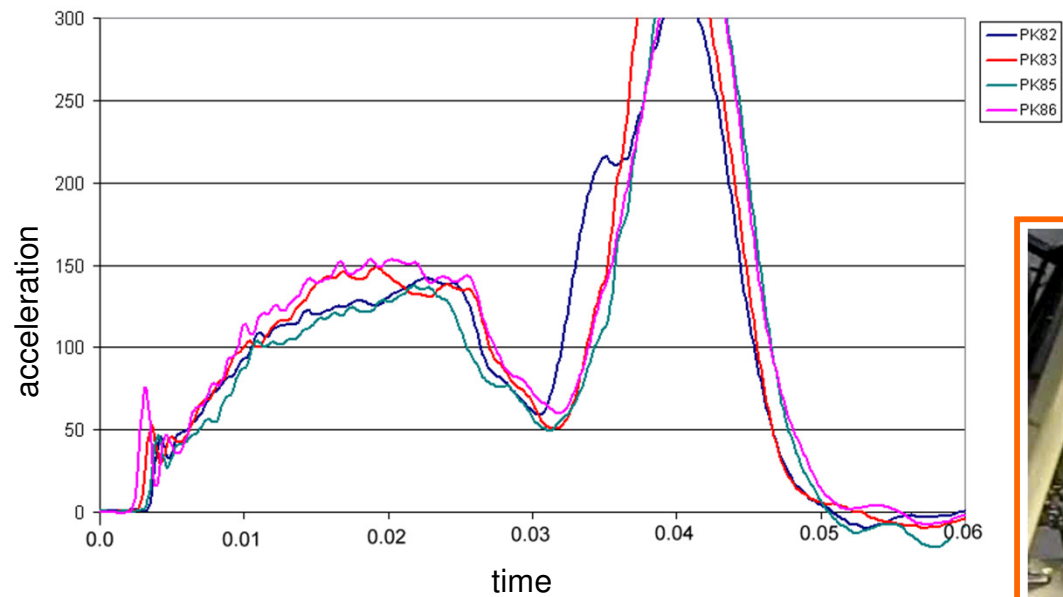
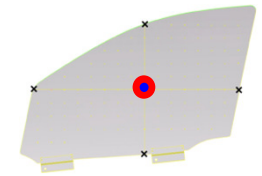

dynamic, $v= 5\text{ m/s}$

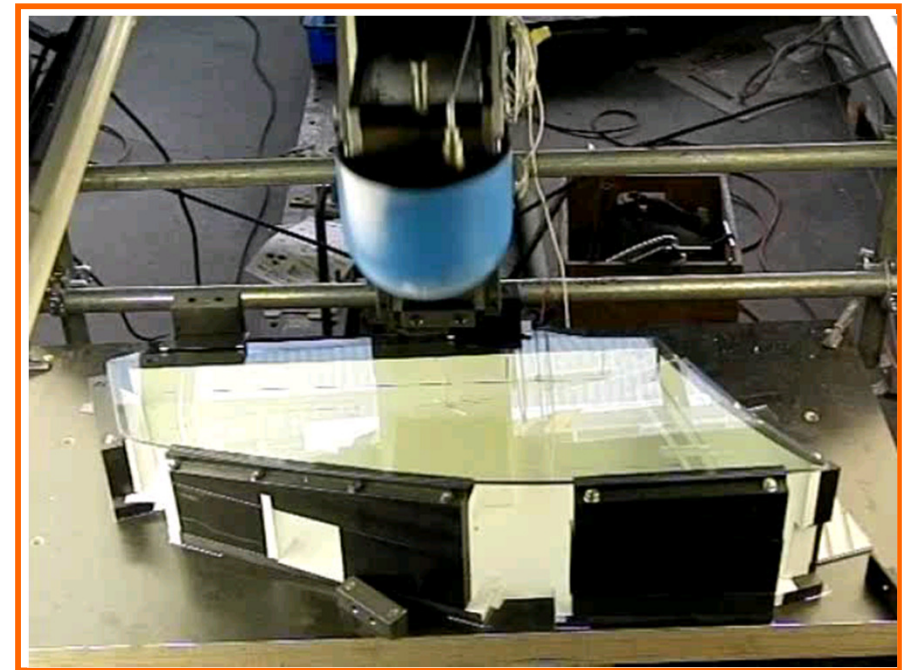

Dynamic tests: Impact on midpoint

- Comparison of dynamic loading of 5m/s (averaged results)

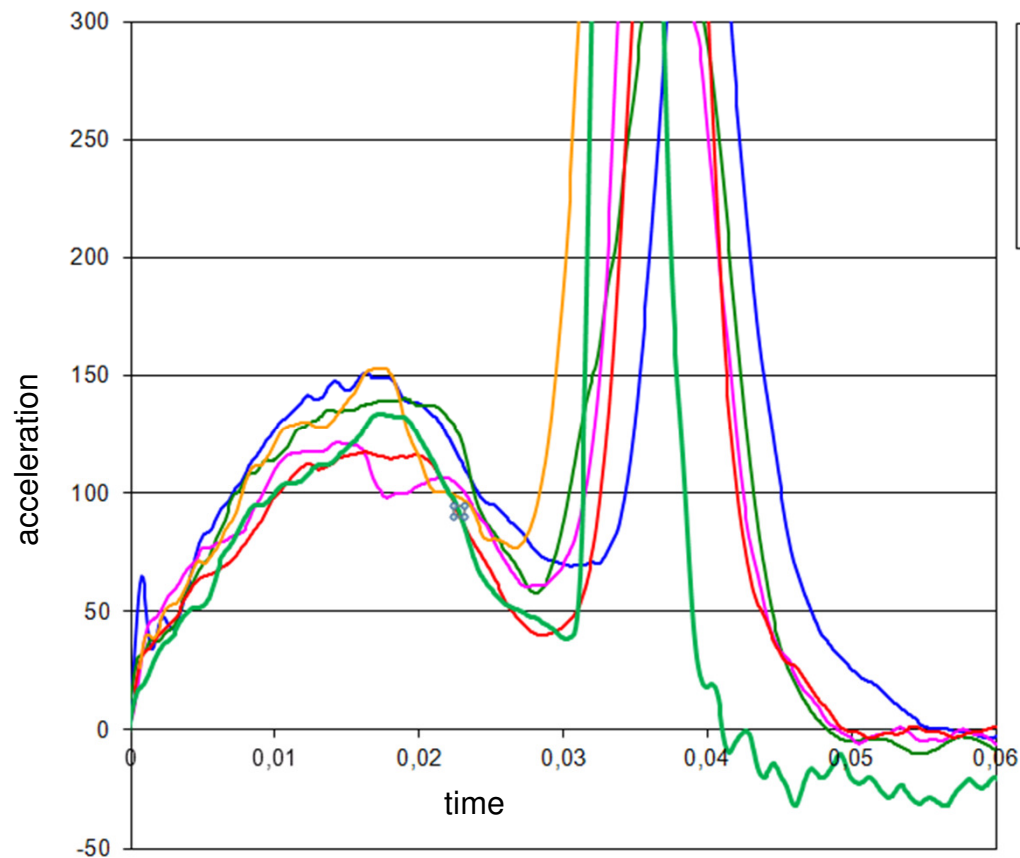

- MW Mitte Intakt
- MW Mitte 1-Punkt
- MW Mitte Raster 100mm
- MW Mitte Raster 50mm
- MW Mitte Raster 75mm alt
- MW Mitte Raster 75mm neu

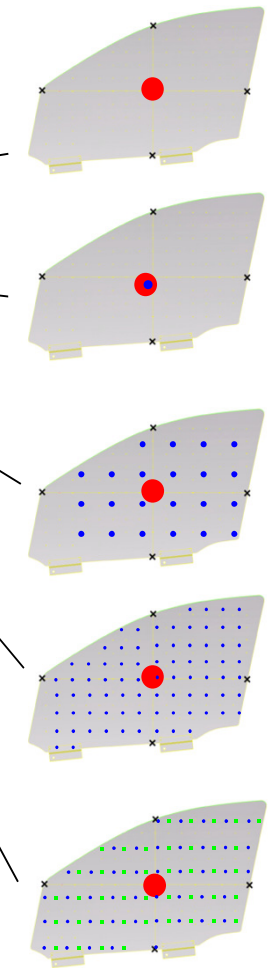

Possibilities to set up model for laminated glass

- Model setup according to experimental conditions
- Various modelling possibilities for the laminated glass structure

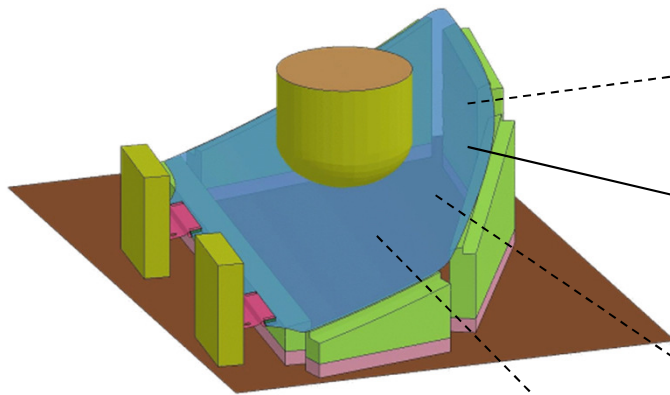

Coincident shell elements

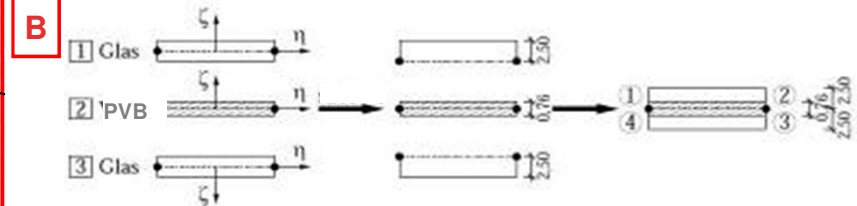
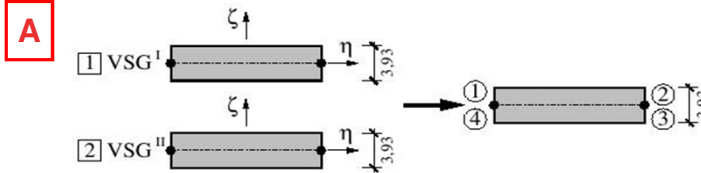

Solid elements



Layered shell elements

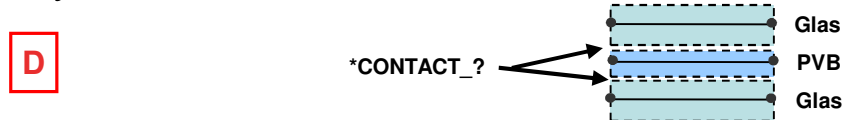

Chosen modelling technique: B

- Three coincident shells elements in thickness direction. i.e. all shells use the same nodal information..
- Each shell represents one part of the layup: Glass/PVB/Glass
- Calibration is done by modifying the material properties of the individual parts.

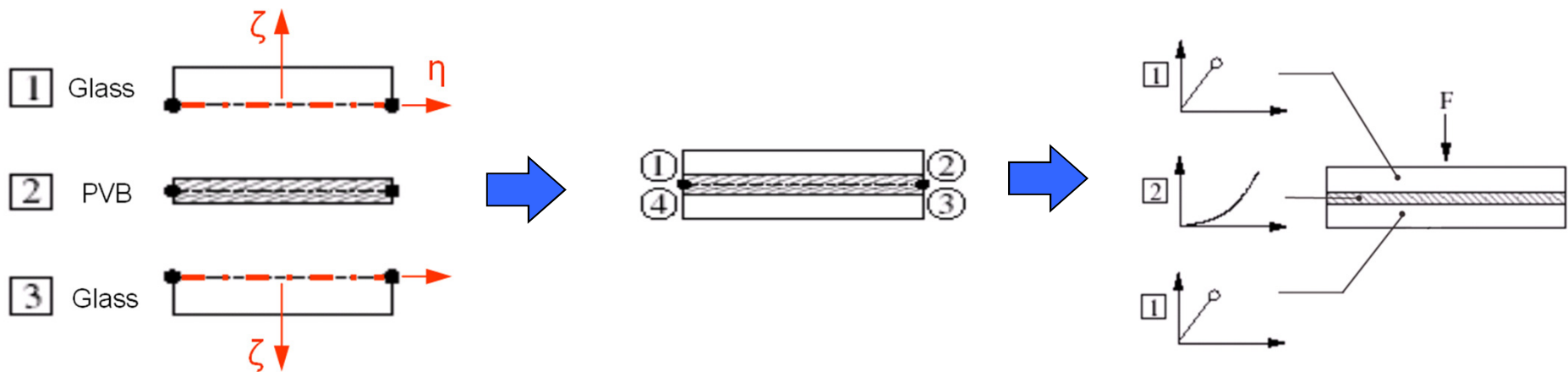

- The characteristic element length in the whole part is about 2.2-2.5mm; the total thickness of the part is 4.7mm.

Modelling technique: B with enhancements

- The representation of the pre-damaged glass is enhanced by elements representing discrete cracks (one element row) modelled with different PID and different material parameters.
- Such parameters are defined via reverse engineering.
- Hence all we find 6 material sets in the glass part: 6 material and 6 Sections cards are necessary:

glass undamaged	(MID/SID)
PVB	(MID/SID)
glass undamaged	(MID/SID)

glass damaged	(MID/SID)
PVB	(MID/SID)
glass damaged	(MID/SID)

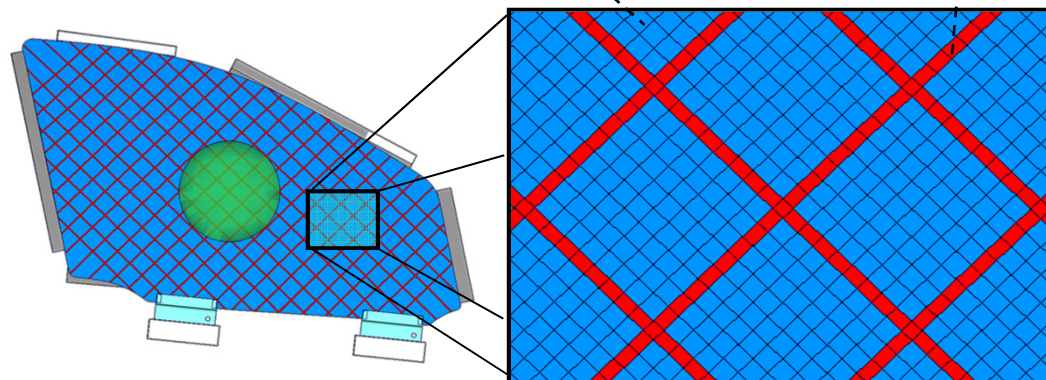

Modelling technique: B with enhancements

- Model setup as shown
- 50mm grid is applied with pre-defined crack-lines
- Acceleration for qs und dynic loading at 5m/s

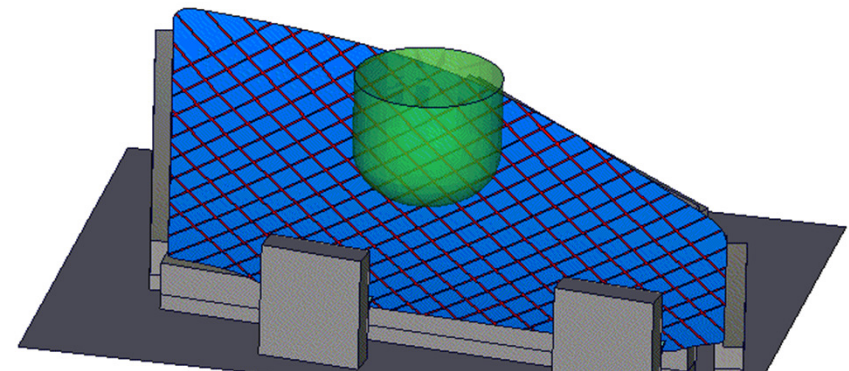
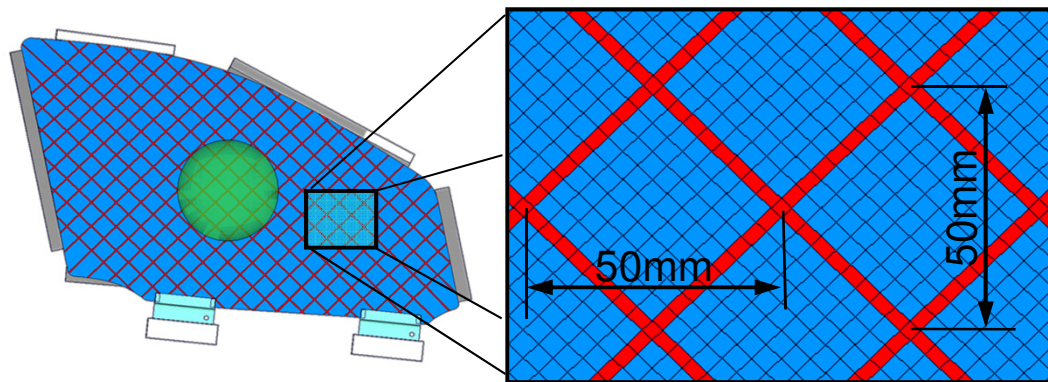
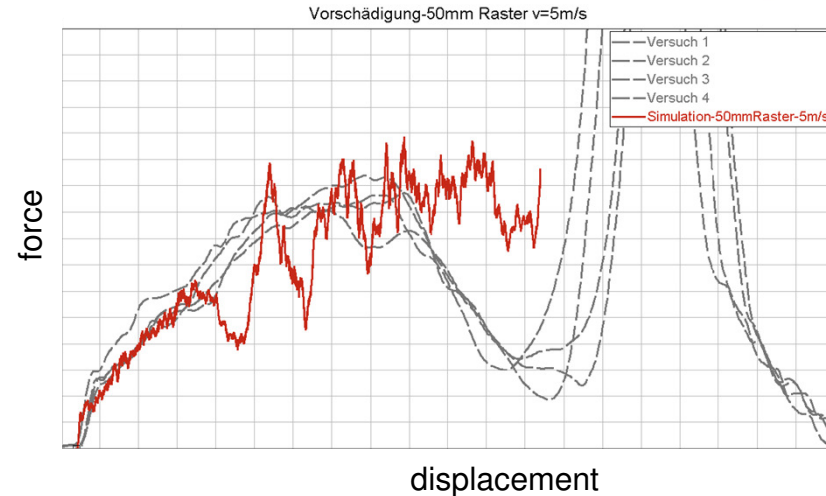
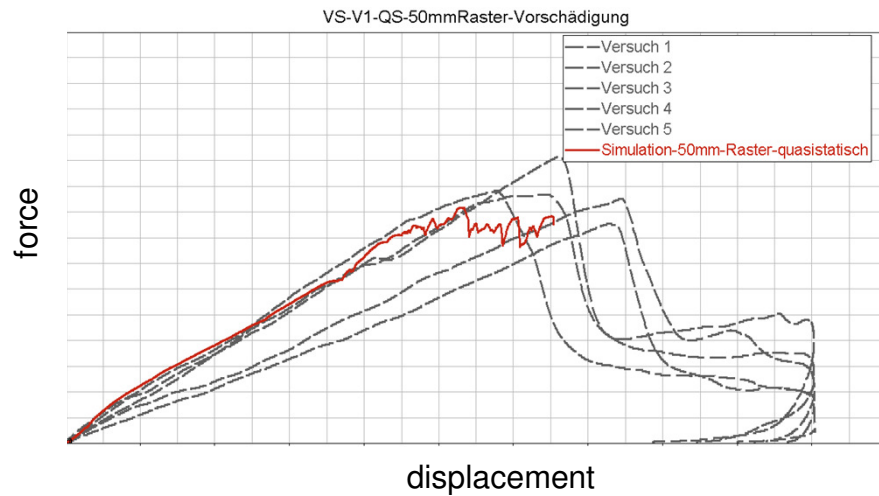
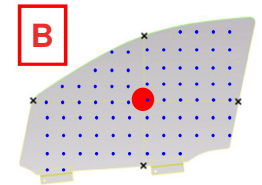

MODELL: mit Vorschäd. 50mm Raster; v=5m/s; Q - State 1 at time 0.000000

Modelling technique: B with enhancements

- Model setup as shown
- 100mm grid is applied with pre-defined crack-lines
- Acceleration for qs und dynic loading at 5m/s

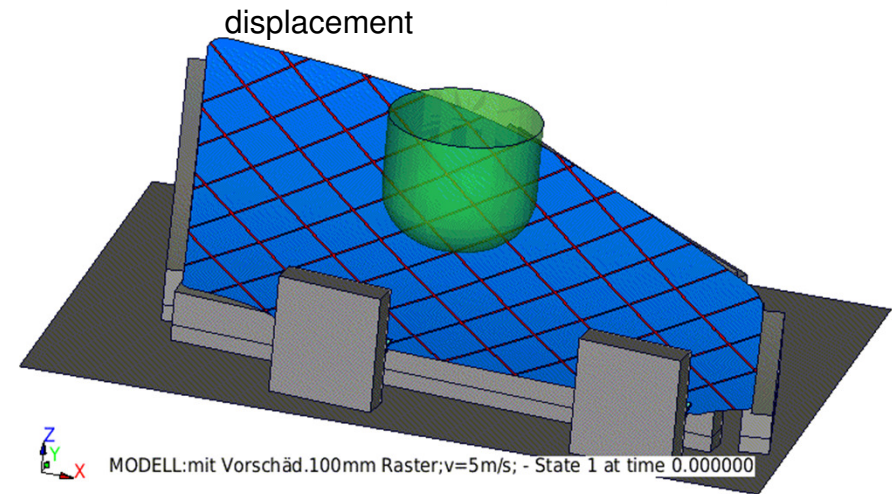
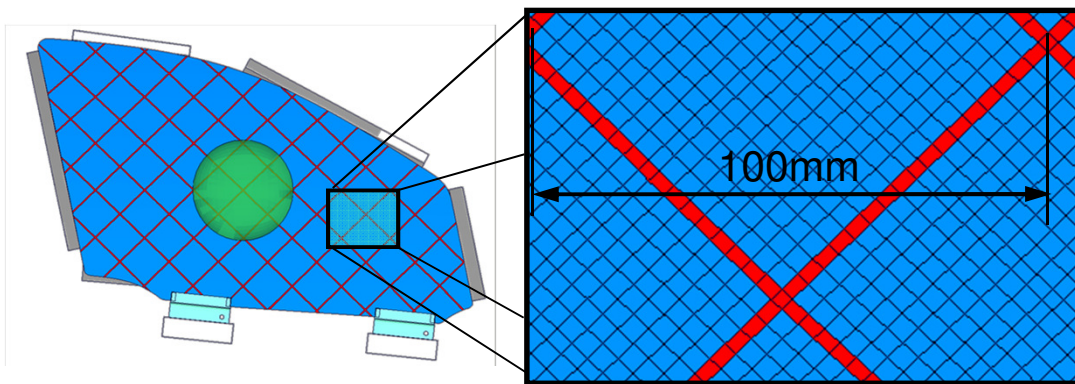
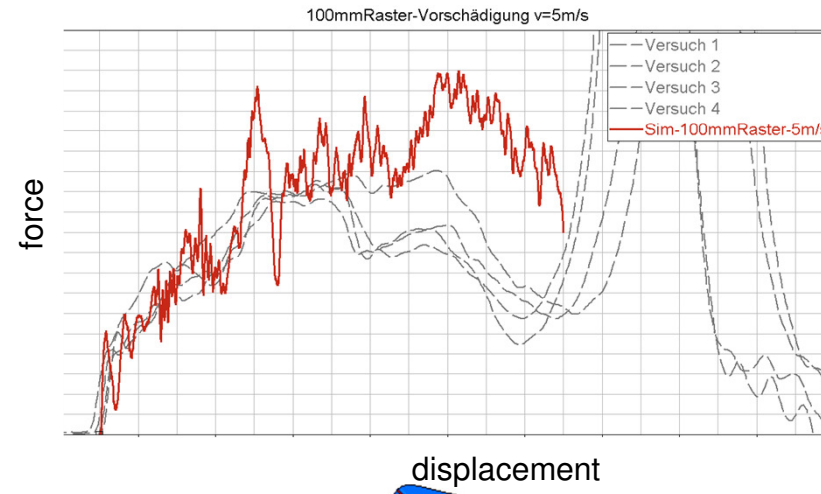
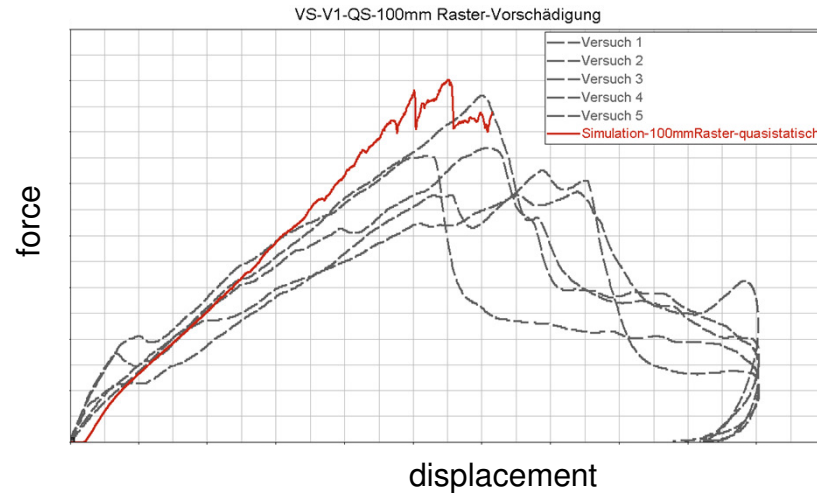
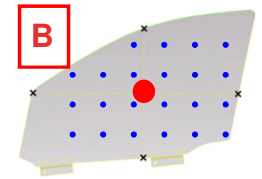

Modelling technique: B with enhancements

- Model setup as shown
- 75mm grid is applied with pre-defined crack-lines (final rule)
- Acceleration for qs und dynic loading at 5m/s

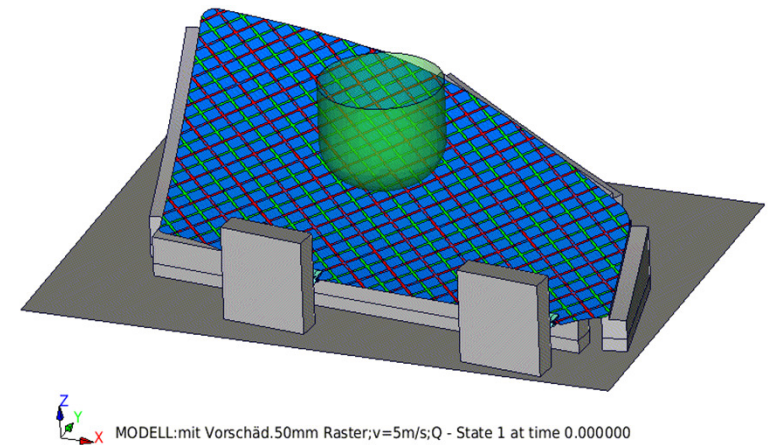
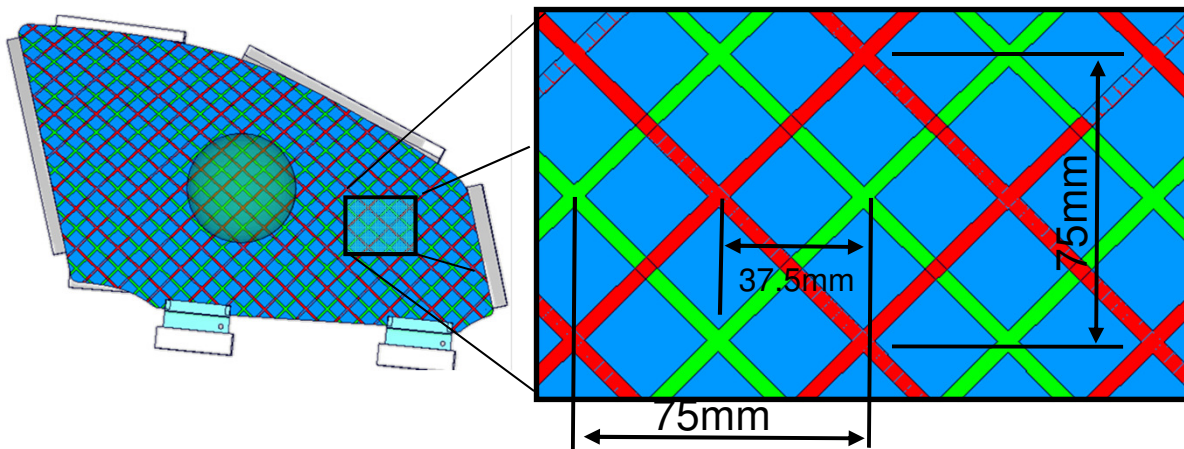
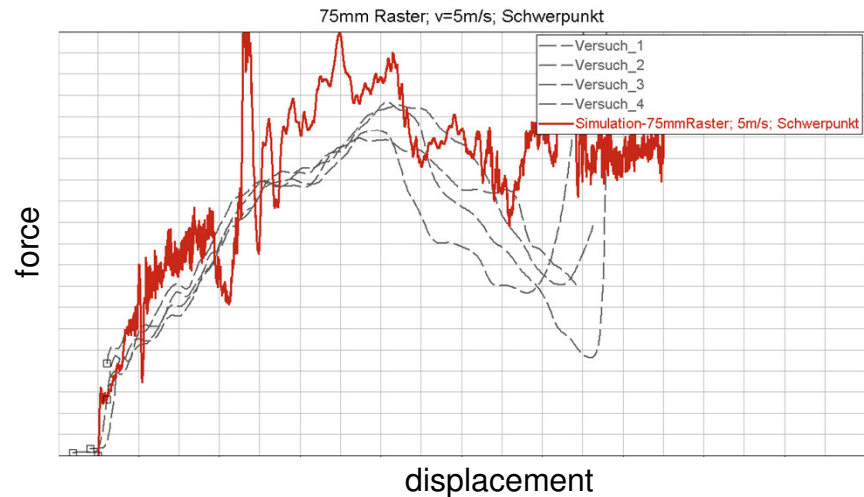
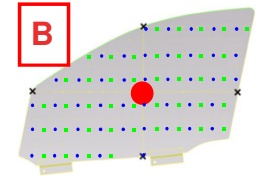



Summary

- The present model requires a mesh that assumes pre-defined crack pattern based on experimental studies. The results gained so far are promising, since the parameters identified can be gained very quickly.
- The crack lines must, however, be used in the final model. Consequently the client has to define requirements according FMVSS226 that third party sub-contractors must meet.
-
- The general approach looks very promising. Further experimental studies with other side window geometrical data will be used as calibration means



FIN

